

The home of the turntable

THE VINYL ENGINE®

For more turntable manuals and setup information
please visit www.vinylengine.com

IMPORTANT CAUTION NOTICE

The service procedures described are intended for the information of *Qualified Electronic Service Technicians*.

Exposure to *Hazardous Voltages* may be involved in some of the service procedures described. The unit under repair should be *disconnected* from the *Line Voltage* before proceeding with any service adjustments involved that require the unit to be opened.

All servicing requiring the unit to be opened should be referred to *Qualified Service Personnel*.

The representative serving your area and THORENS disclaim any responsibility for person injury or damage for failure to observe this warning.

CHASSIS COMPONENTS

1. Preparation for Servicing

Remove the TX 110 dust cover and the outer turntable platter. The transparent rear panel can be separated from the unit by pushing outward on one of the hinge assemblies and pressing on the panel.

2. Platter Bearing

a) The lubricant of the sintered platter bearing requires replenishment only after several thousand hours of operation. Use an appropriate sinter-bearing oil such as Mobil DTE Heavy Medium (available from THORENS).

b) If defective, the platter bearing assembly (7845007) is replaced from above by removing the three screws. The concentric spring washer enables the platter to be adjusted parallel to the chassis by appropriately tightening the screws. Lubricate the bearing.

3. Tone Arm Platform

- a) The height of the stylus tip is as follows:
- | | |
|------------------|---|
| tone arm raised | 6 – 9 above the surface of the record |
| tone arm lowered | approximately even with the height of the metal platter surface |

To change the stylus height, loosen the screw securing the tone arm platform with a 1 mm Allen wrench introduced between the tone arm rest and the bearing assembly. Note that the damping of the lift mechanism may influence the adjustment.

- b) Replacement of the platform clasp (6879176): twist out the pivot pin with a pair of pliers, remove the clasp.
- c) Further details of the lift mechanism are treated in Section 6.

4. Front Panel Removal

Pull off the knobs. If too firmly seated, place a piece of thick paper in front of each knob and pry off with a flat screwdriver.

Remove the countersunk screw.

Insert a slender screwdriver into the slot underneath the front right-hand side of the unit and twist slightly to release the panel.

Grasp the panel on the right-hand side, lift up to the left.

5. Rear Panel Removal

Remove the screw, lift the panel, and tilt it toward the rear. After the rear panel has been removed, the motor control circuitry can be serviced; see Section 9 b).

6. Functional Checks of the Front Panel Controls

Connect the unit to a mains receptacle. The functional checks are performed with the front panel removed (Section 4).

TD 110

Speed Selector. The proper function is indicated by a "click" in the power supply and the illumination of the stroboscope lamp. The motor is started. Refer to Section 11 if the unit fails to turn on or off. The contact must close when the selector is turned to 45 RPM.

Fine Speed Control. See TD 115 (below).

Tone Arm Lift Control. The tone arm must be raised and lowered smoothly. The raising and lowering times for production units are as follows:

raise	1.5 – 3.5 seconds
lower	1.5 – 4.0 seconds

These times can be altered by employing differently dimensioned springs.

TD 115

Speed Selector. The proper function is indicated by a "click" in the power supply and the illumination of the stroboscope lamp. The motor will make a fraction of a turn. Refer to Section 11 if the unit fails to turn on or off. The contact must close when the selector is moved to 45 RPM. If loud actuation noises accompany selector movement, replace the felt damping pads (front left, right rear) as required.

Fine Speed Control. Check for smooth rotational movement. The encapsulated potentiometer can be eased out of the base using a screwdriver with light finger pressure exerted toward the rear of the unit. The position of the assembly can be adjusted within the holding collar.

Start Control. When the control is actuated toward the left, the sliding assembly must latch, the holding magnet pull in, and the start contact remain closed. If latching does not occur, the position of the pin in the grid must be changed to increase the latching force, or the clear plastic lever (6846055) must be replaced.

When the control is actuated toward the right, the magnet must pull in and the start contact close. When the control is released, it must be returned smoothly to the middle position by the action of the middling spring (6846068) at the front. The contact opens.

If the motor does not start, first verify that the start contact is closing and proceed to the servicing information for the motor control circuitry (Section 9).

Replace the magnet if it does not hold the clear plastic lever after starting has been initiated. When installing a new magnet, first fasten the screws loosely, let the magnet pull in once by actuating the control, and tighten the screws.

Tone Arm Lift Control. When actuated toward the left, the sliding mechanism must latch onto the clear plastic lever in both the START and MANUAL modes. Actuation toward the right unlatches the control. If latching does not occur, the catch can be adjusted by turning the painted screw after the chassis has been raised (Section 7).

The raising and lowering times for production units are as follows:

raise	1.0 – 2.0 seconds
lower	1.5 – 3.5 seconds

These times can be altered by employing differently dimensioned springs.

7. Raising the Chassis

Remove the front and rear panels according to Sections 4 and 5.

Pull off the drive belt barrier (6845032) and remove the belt. Pull out the inner turntable platter. Remove the compensation belt underneath. Unscrew the plastic arresting bolt next to the bearing assembly. It is advisable to reinsert the inner turntable platter to prevent contamination.

Lift the chassis at the front and guide out from the rear. The chassis can now be rested on its right-hand side in the base and supported upright on the left using the rear panel previously removed.

8. Chassis Adjustment

Check the condition of all four chassis support modules (7845016). The maximum allowable droop of the spring inserts is 5 mm. If a spring is excessively stretched, replace the entire module by unscrewing the plastic nut underneath the base.

Remount the chassis on the four supports. Add the turntable platter and rubber mat. The proper width of the slit between chassis and base is approximately 4 mm. Verify parallel alignment.

The height of the chassis can be adjusted if necessary by turning the upper part of each support when the chassis is raised.

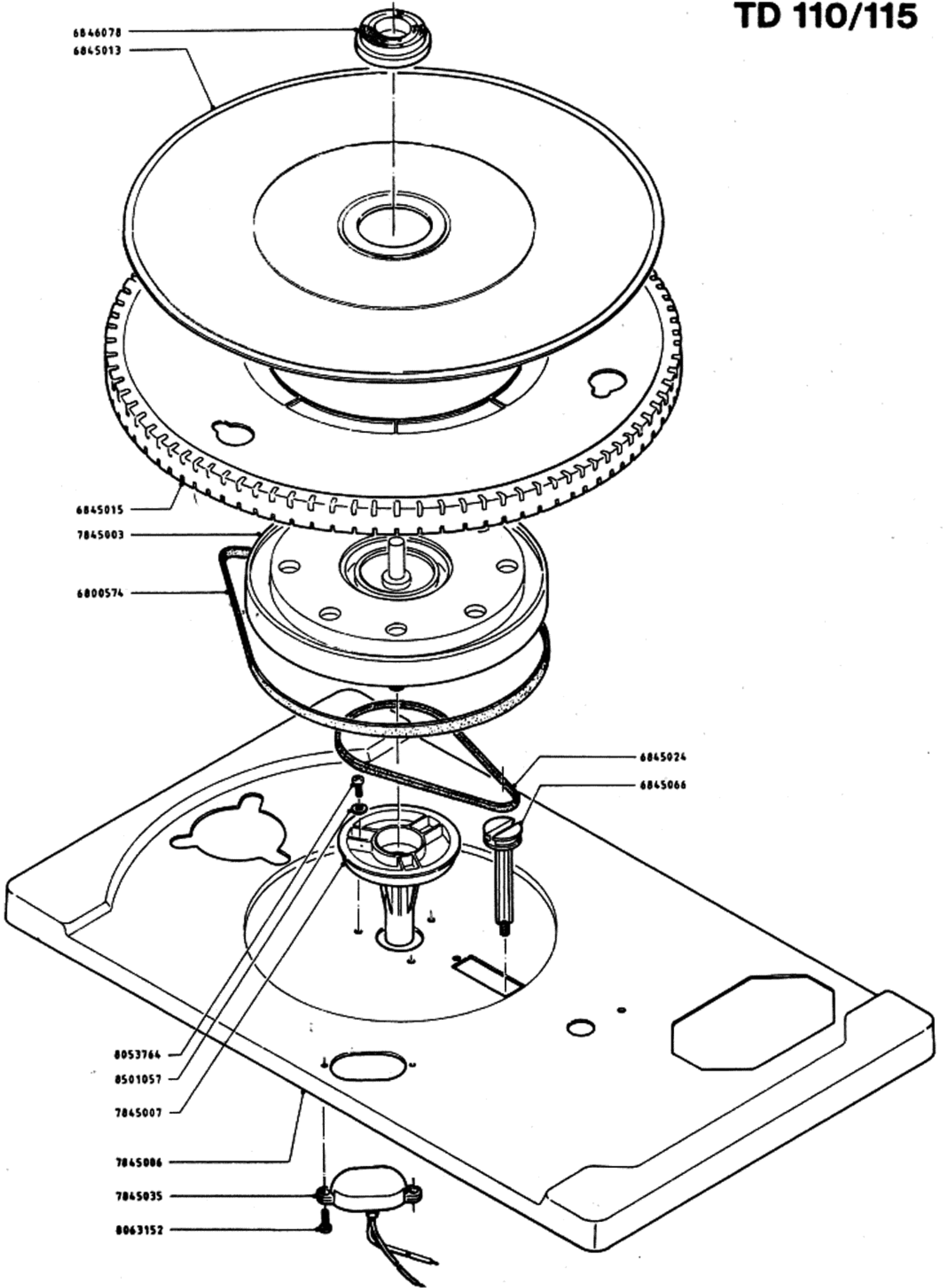

TD 110/115

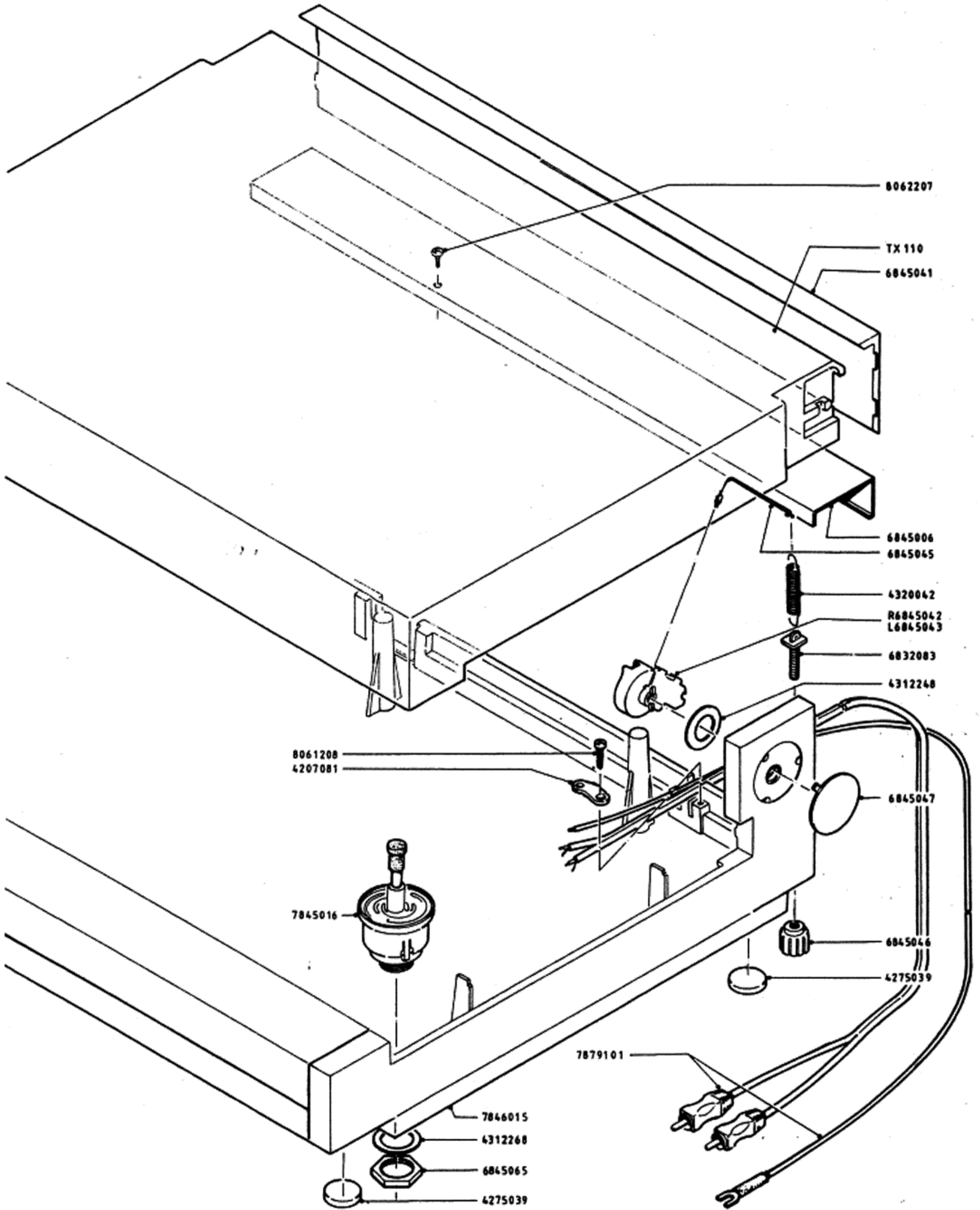

TD 110

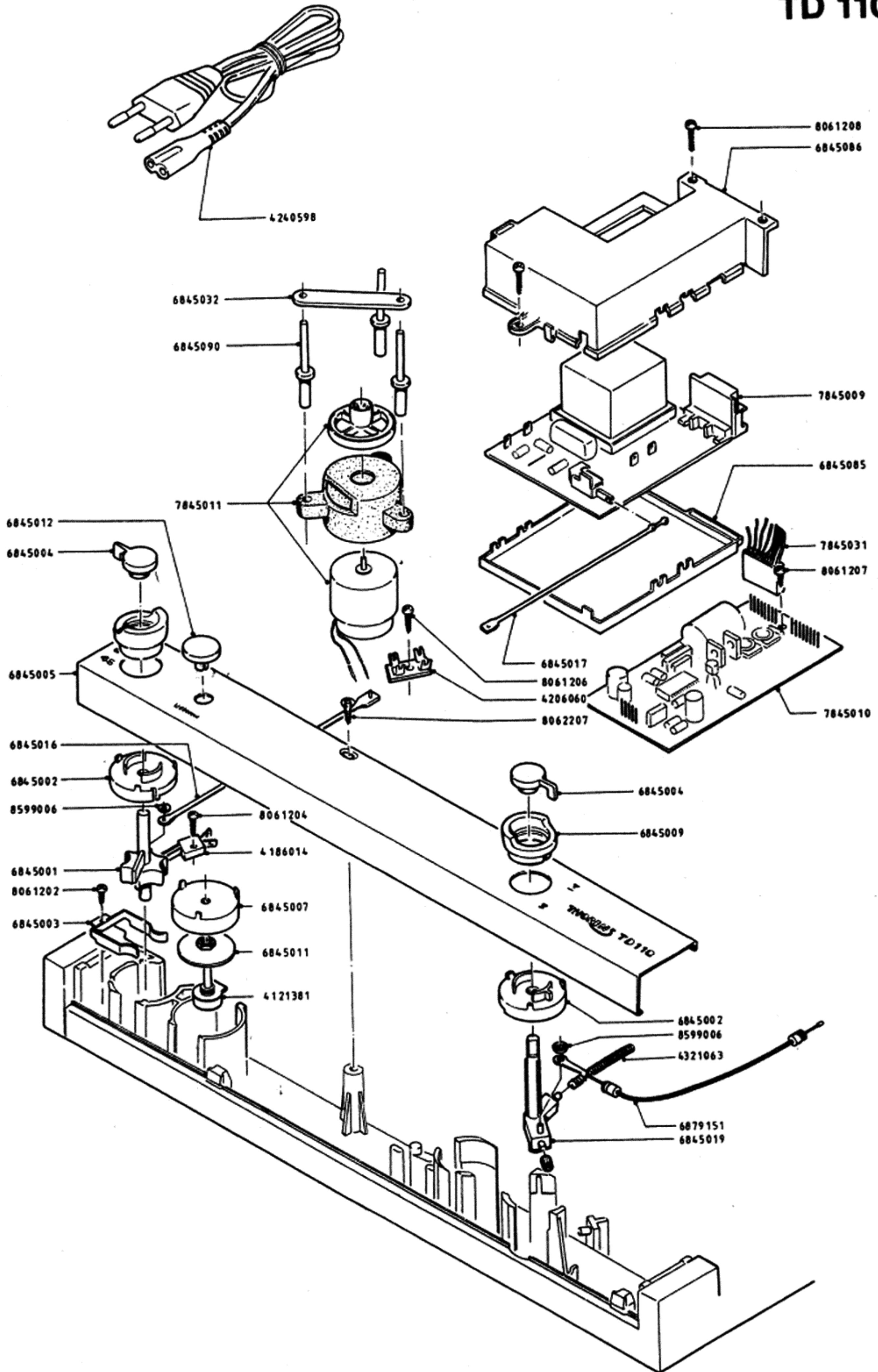

TD 115

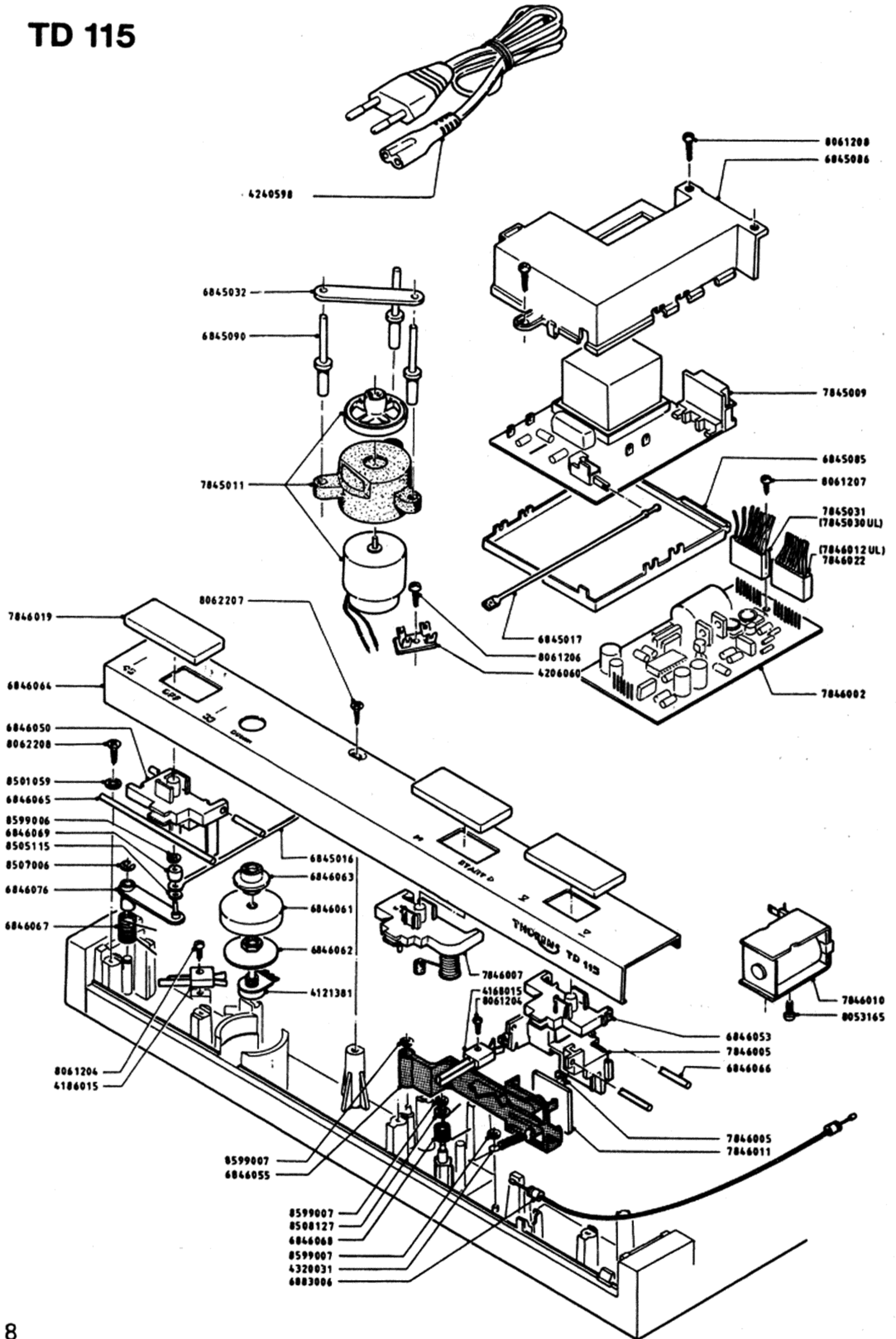

LIST OF SPARE PARTS – CHASSIS COMPONENTS

4121381	Potentiometer	6845045	Tension cord	7846005	Lift control assembly
4186014	Contact assembly	6845046	Knurled nut	7846007	Start control assembly
4186015	Contact assembly	6845047	Hinge cover	7846010	Holding magnet
4206060	Terminal strip	6845065	Hexagonal nut	7846011	Armature assembly
4207081	Cable clamp	6845066	Arresting bolt	7846012	Auto-stop cable UL
4240598	Power cord	6845085	Lower cover	7846015	Base
4275039	Felt pad	6845086	Upper cover	7846019	Slide knob
4312248	Washer	6845090	Mounting stud	7846022	Auto-stop cable
4312268	Washer	6845050	Control 1	7879101	Pickup cables
4320031	Tension spring	6846053	Control 3	8053165	Screw DIN 7985 M 3 x 8
4320042	Tension spring	6846055	Lever	8053764	Screw DIN 7985 M 3 x 8 black
4321063	Pressure spring	6846061	Potentiometer guide	8061202	Screw DIN 7981 B 2.2 x 6.5
6800574	Drive belt	6846062	Potentiometer disk	8061204	Screw DIN 7981 B 2.2 x 13
6832083	Adjustment bolt	6846063	Potentiometer knob	8061206	Screw DIN 7981 B 2.9 x 6.5
6843285	Angular lever	6846064	Front panel TD 115	8061207	Screw DIN 7981 B 2.9 x 9.5
6845001	Detent shaft	6846065	Left rod	8061208	Screw DIN 7981 B 2.9 x 13
6845002	Guide disk	6846066	Right rod	8062207	Screw DIN 7983 B 2.9 x 9.5
6845003	Detent spring	6846067	Cylindrical spring	8062208	Screw DIN 7983 B 2.9 x 13
6845004	Switching knob	6846068	Middling spring	8063152	Screw DIN 7516 AM 3 x 8
6845005	Front panel TD 110	6846069	Roller	8501057	Washer DIN 125 A 3.2
6845006	Rear panel	6846076	Roller bar	8501059	Washer DIN 125 4.3
6845007	Enclosure guide	6846078	Strobe adapter	8505155	Washer DIN 433 2.2 PR
6845009	Knob guard	6879151	Bowden cable	8507006	Clip washer DIN 6799 3.2
6845011	Securing disk	6883006	Bowden cable	8508127	Washer DIN 9021 3.2
6845012	Rotary knob	7845003	Inner platter	8599006	Arresting washer 2
6845013	Rubber mat	7845006	Chassis	8599007	Arresting washer 3
6845015	Outer platter	7845007	Bearing assembly		
6845016	Transmission strip 1	7845009	Power supply board		
6845017	Transmission strip 2	7845010	Motor board TD 110		
6845019	Lift shaft	7845011	Motor assembly		
6845024	Compensation belt	7845016	Support module	4183018	Power switch
6845032	Drive belt barrier	7845030	Motor cable UL	5511057	Packing carton
6845041	Rear panel	7845031	Motor cable	5511058	Corrugated panel
6845042	Right rider	7845035	Stroboscope assembly	5511059	Separator
6845043	Left rider	7846002	Motor board TD 115	7845028	Styrofoam packing

9. Motor Control Circuitry

a) *Circuit Description.* The DC motor is fed from T 203, the base voltage of which is supplied by the motor control IC (Z 201). The voltage magnitude is dependent on the tachometer frequency f_G , the setting of the speed selector, and the motor current. The signal from the 72-pole tachometer generator (G) is fed to pins 2 and 3 of the motor control IC. The tachometer signal is limited within the IC; integration follows using C 204. A square-wave signal, with pulse width determined by the DC voltage on pin 5 (speed determination), appears at pins 6 – 7 with frequency $2 f_G$. It is converted to a triangular wave with C 202. The voltage on D 208 mirrors the current of the motor and is introduced as a control parameter through T 201 into pin 8. The RC network (R 211, C 210) at pin 10 is employed for internal generation of a 20 KHz sawtooth wave, which is fed into pin 9 for chopping the control signal. The pulse-width-modulated, chopped output signal at pin 16 is smoothed by an LC network (Dr 101, C 126) and fed to T 203. An internal voltage regulator serves as a voltage reference source (+3 V).

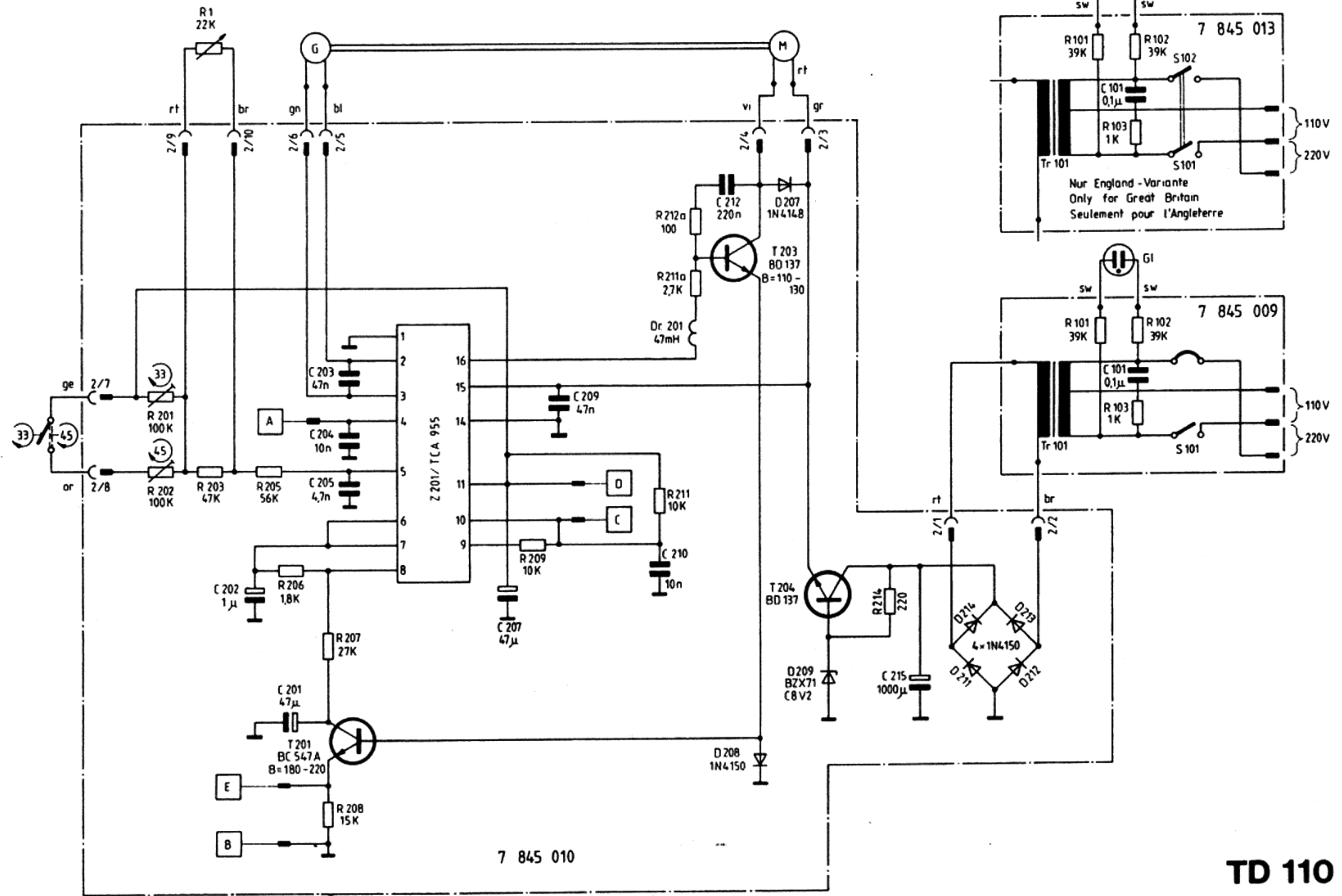

7 845 010

TD 110

In the TD 115, a phase inverting stage for the start-stop function is provided between pins 13 and 12. When the circuit is turned on and voltage transients are likely, D 206 and C 213 prevent the voltage on pin 13 from sinking below about +2.3 V, i.e., +3 V on pin 11 minus the 0.7 V drop of D 206; D 205 discharges C 213 thereafter. The voltage on pin 12 is thus held at approximately 0 V, and D 202 conducts to prevent, via Z 201, the motor from starting. T 205 is turned on so that the holding magnet does not engage. D 201 is the discharging path for C 201.

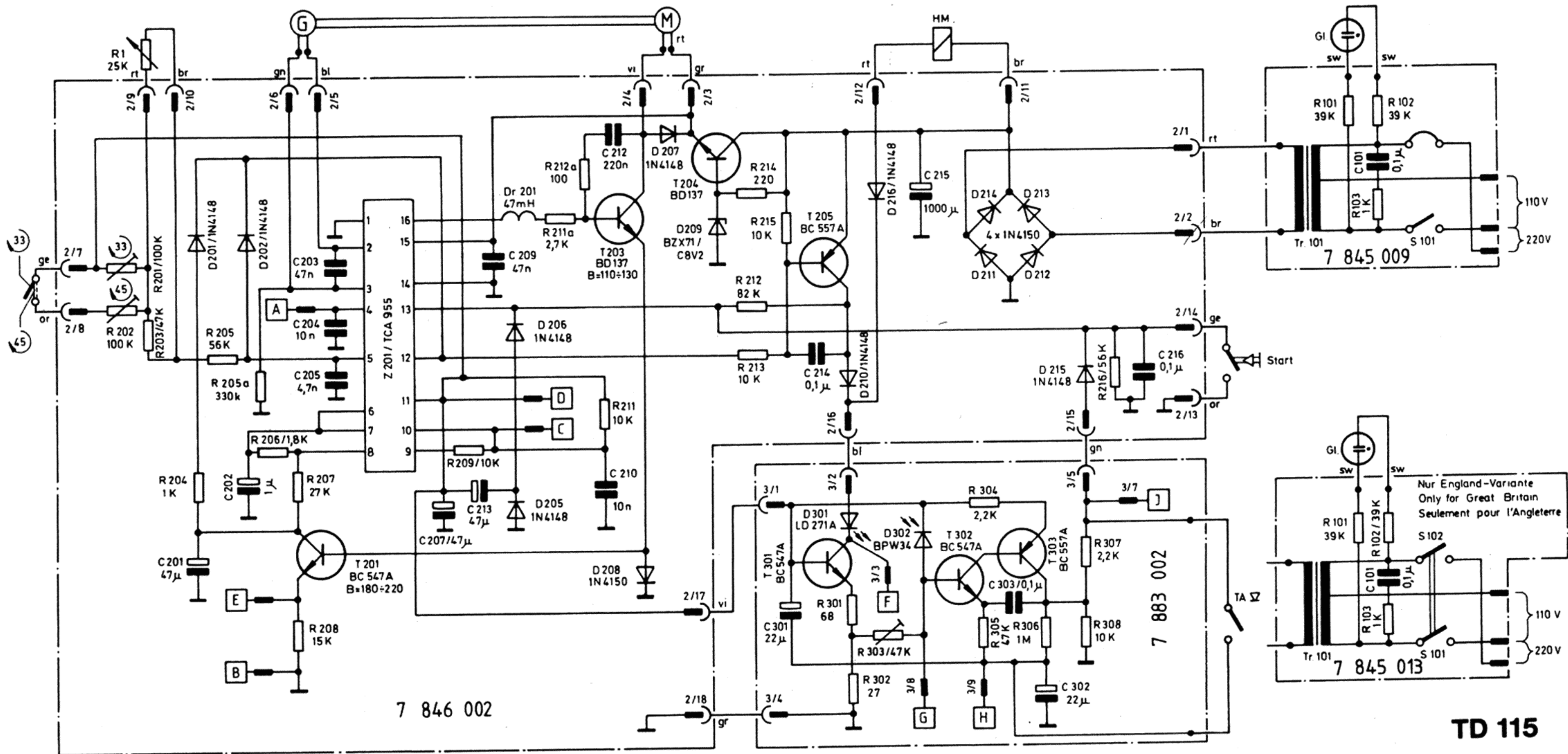

TD 115

When the START switch is closed, the voltage on pin 13 is forced to 0 V. The voltage on pin 12 rises to about +16 V. D 201, D 202, and T 205 are turned off. The holding magnet pulls in. The resulting low voltage on the collector of T 205 holds the voltage on pin 13 below its threshold value of +1.1 V. When, however, the auto-stop circuit delivers a positive voltage through D 215, the motor is stopped as described above.

b) *Access to the Motor Control Circuitry.* After the rear panel has been removed as described in Section 5, the motor control circuitry can be serviced. Remove the screw, partially pull out the circuit board, remove the connector(s), take out the board, reinsert the connector(s) as required.

- 10-pin connector: motor
- 8-pin connector: auto-stop (TD 115)

- e) *Adjustment of the Speed Ranges.* The speed range trimmers should be readjusted whenever the motor control circuitry has been repaired or the motor replaced. Pull off the fine speed control knob and position the shaft at the electrical middle point (flat surface along 5 – 11 o'clock line). Adjust the trimmers R 201 (33 RPM) and R 202 (45 RPM) to achieve a stationary stroboscope pattern at each speed.

10. Auto-Stop Circuit (TD 115)

- a) *Circuit Description.* During record play, the optical path between the light-emitting diode D 301 and the photodiode D 302 is interrupted by the rotating shutter (7883001). D 302 is thus highly resistive, T 302 and T 303 are turned off, and the potential at the output (3/7) is 0 V. When the optical path is opened at the end of the record or in the region of the tone arm rest, the optical intensity of D 301 (determined by the constant-current source T 301) and the angular position of the shutter determine the resistance of D 302. The magnitude of the resulting voltage increase at the base of T 302 is determined by the setting of R 303. The amplifier T 302/T 303 functions as a differentiator owing to R 306 and the parallel combination of C 301 and C 302. When the stylus travels into the lead-out groove, the base voltage of T 302 rapidly increases. The output voltage of the differentiator (at the collector of T 303) rises as a result to more than 2.2 V and remains present for several seconds. The stopping voltage is fed through D 215. When the tone arm is raised, the switch TA closes, thereby bridging R 306 to prevent generation of a stopping impulse. When the unit is turned on, C 302 is first charged to about +1.5 V by virtue of the capacitive divider. T 302 is turned off as a result, preventing the generation of spurious stop impulses due to turn-on disturbances. C 302 then discharges until the normal operating point is reached. C 303 prevents the circuit from being triggered by noise impulses.
- b) *Rotating Shutter.* If stopping occurs at the wrong point, the position of the shutter must be readjusted. Connect a DC voltmeter between test pin 3/8 (middle unoccupied pin next to the connector) and 0 V (negative side of C 215). Start the turntable. While moving the tone arm over the lead-out groove region, note the highest value of the voltage attained (+1.4 to +1.8 V; in the event of deviation, see part c below). Position the tone arm with the enclosed template to hold the stylus point 48 mm from the center of the turntable platter. Loosen the shutter screw. Position the shutter in the middle of the slot of the diode assembly and rotate to the point where the voltage just reaches the highest

value previously determined. Tighten the screw and test operation with a phonograph record.

- c) *Circuit Performance Tests.* Place the stylus guard on the pickup cartridge. Turn on the turntable, move the middle control to START, lower the tone arm and hold in the region of the arm rest. The voltage on the test pin 3/8 must lie between +1.4 and +1.8 VDC; if necessary, adjust with R 303. Move the tone arm over the record playing area. The voltage at 3/8 should fall to about +0.7 V. At pin 3/7 (first unoccupied pin next to the connector) the potential should be 0 V. After a few seconds, move the tone arm to the lead-out groove region. The voltage at 3/7 must rise rapidly to at least +2.2 V and decrease slowly. The turntable motor is turned off.

In the event of insufficient voltage at 3/7, verify that the TA and start contacts are opening, test the transistors, and replace the circuit capacitors.

When the tone arm is raised, the voltage at 3/7 rises to about +1.3 V in the shut-off region. The motor is not turned off.

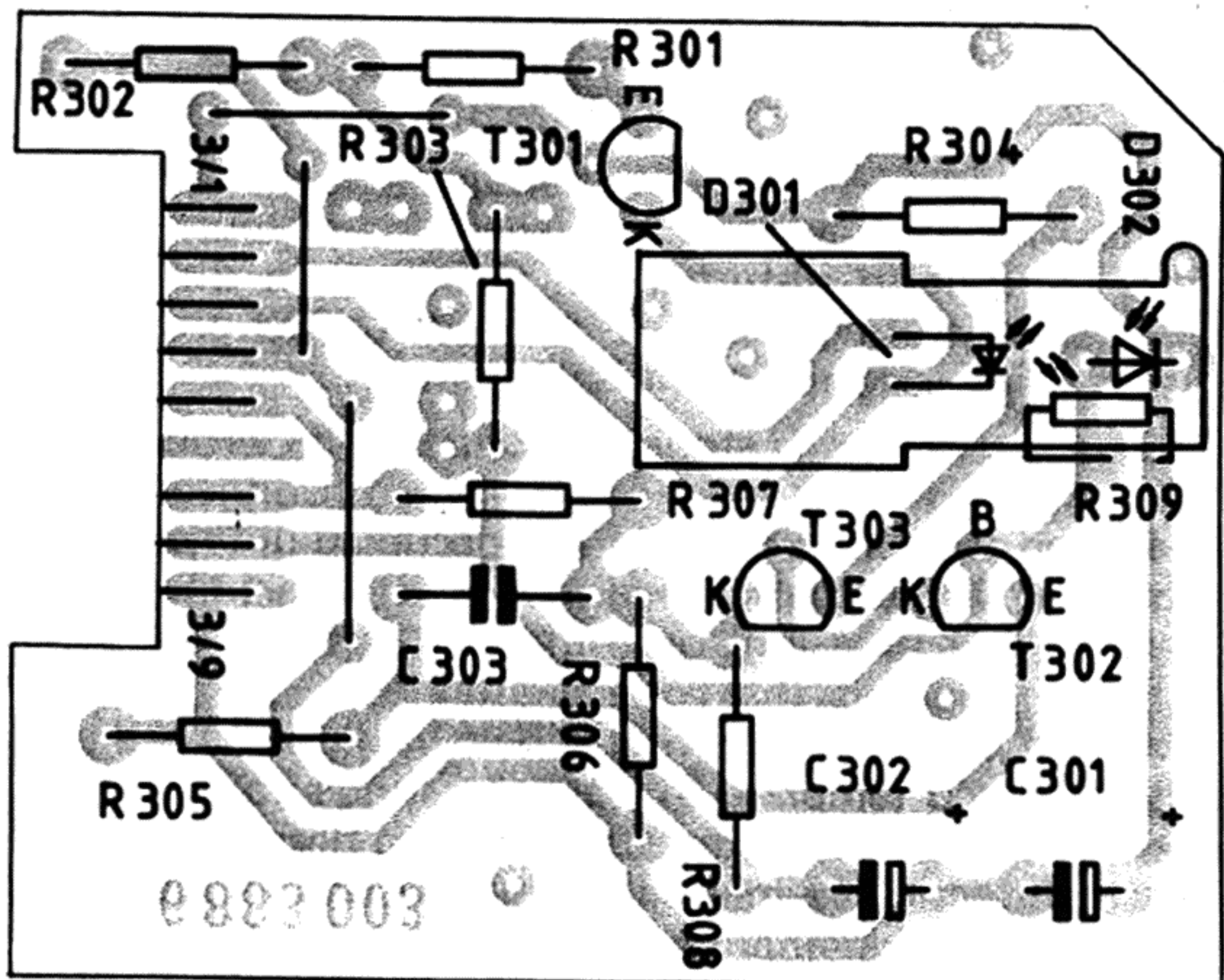

11. Mains Power Switch

If the mains power switch (4183018) does not function properly, disconnect the mains cord, remove the power supply cover, and inspect the switch for defects. The switching action can be checked by pulling on the plastic transmission strip. The length of the strip is adjusted by relocating the peg in the grid. Reseal the peg after the proper switching action has been attained.

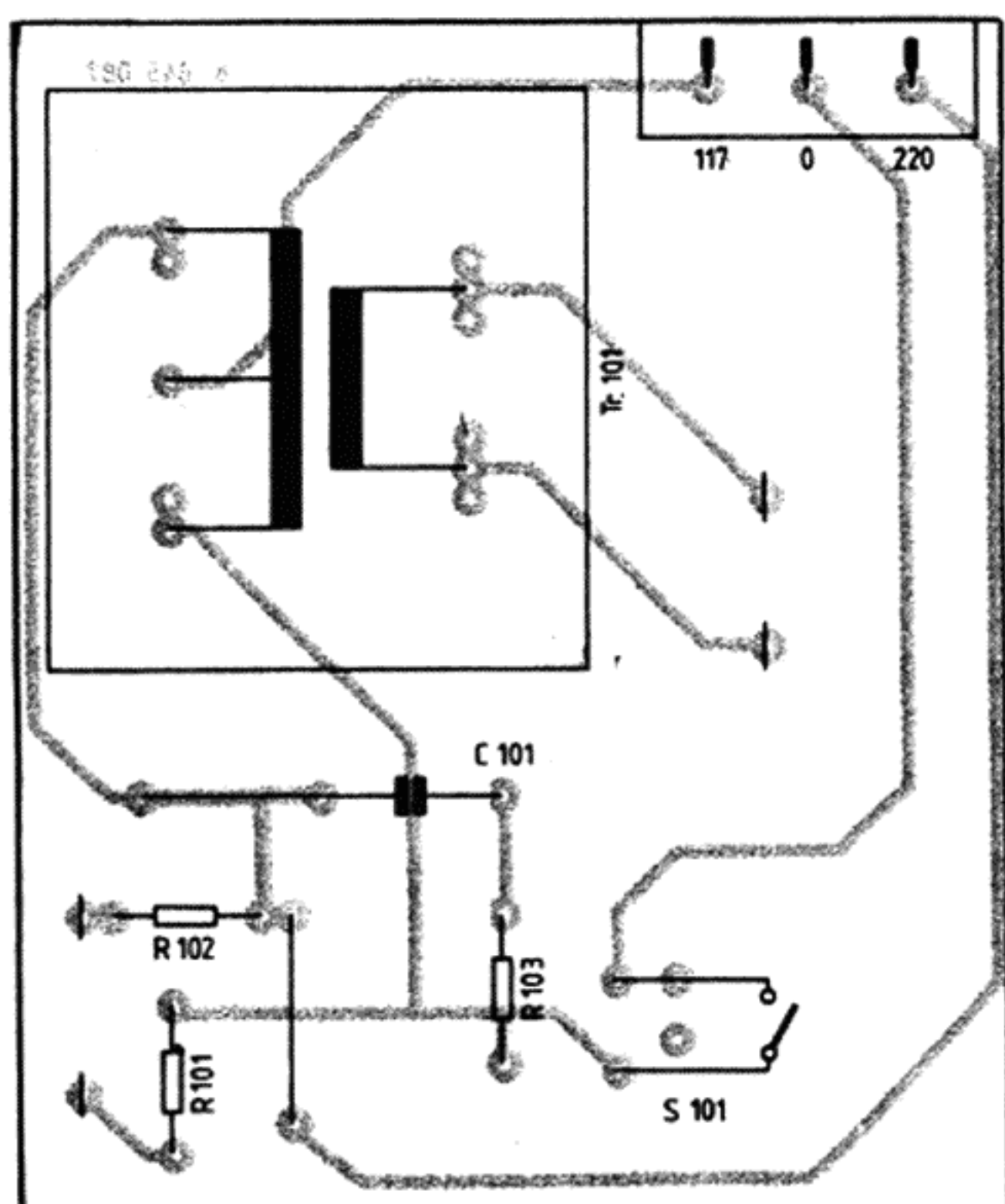

7845009

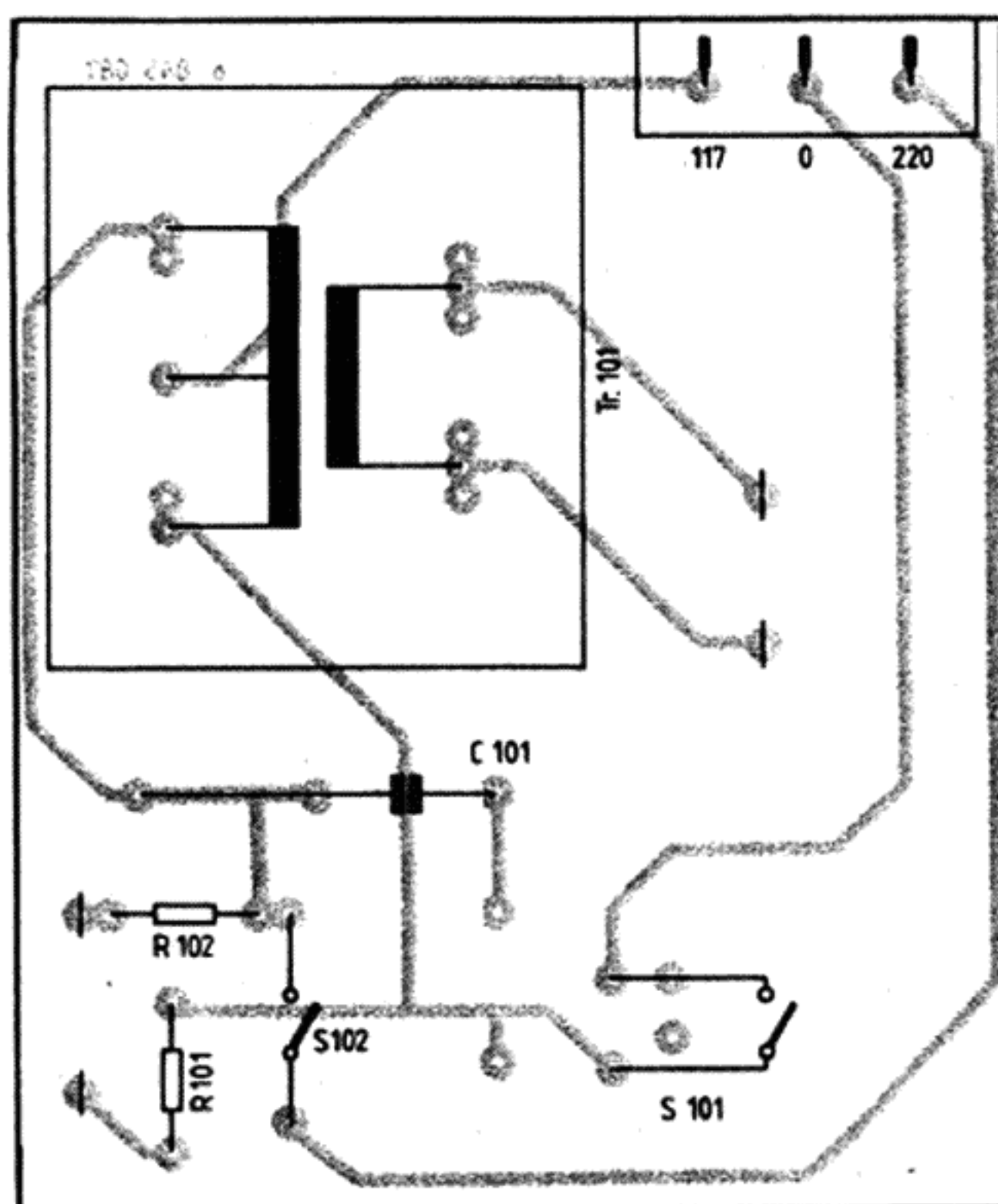

7845013

Power Supply

12. Stroboscope Lamp

A defective stroboscope lamp is to be replaced as a complete assembly (7845035) with connecting wires. Disconnect the mains cord, open the power supply, unsolder the wires, and remove the screws holding the lamp assembly.

AUDIO COMPONENTS, TONE ARM

13. Elimination of Hum Disturbances

If hum disturbances persist despite observance of the measures treated in the instruction manual, use an ohmmeter to check for a possible — incorrect — low-resistance path between the black grounding wire and the audio connectors. If electrical conduction be determined, repeat the test with the cartridge wand removed. A collar of insulating material between the tube and the head of the wand is intended for electrically separating the chassis ground system (black wire) from the audio ground in the turntable. Finally, check the shield connection of the pickup cartridge, referring to the manufacturer's specifications. The green wire in the head should be joined with the shield connection.

14. Tone Arm

- a) To test the lateral friction of the arm, turn the stylus force adjustment to zero to achieve "floating balance". Set the anti-skating force to its lowest value. When positioned over the lead-out groove region and released, the tone arm must move smoothly to the right and swing back and forth at least four times. In the event of increased friction, raise the chassis as described in Section 7, remove the cover underneath the bearing assembly, and check the audio leads.
- b) The mechanical tone arm block must permit the tone arm to be moved to a distance of at least 30 mm from the platter spindle in the lead-out groove region. To change the position of the block, turn the upper ring (7879111) on the bearing assembly after loosening the three screws with a 1.5 mm Allen wrench.
- c) Repairs of the TP 30 tone arm bearing assembly should not be attempted because of the specialized measurement equipment required. To replace the tone arm, proceed as follows: remove the cartridge wand, lift the chassis as described in Section 7, pull out the connector, remove the audio cable clamp, separate the Bowden cable from the lift control at the front, clamp the lever of the Bowden cable in the TD 115 to the cable guide with a paper clip to protect the switch contacts, remove the three screws, and remove the bearing assembly from below by guiding through the hole. After installing a new arm, observe Sections 3 a) and 14 b).

15. Equipping the Turntable with Low-Capacitance Cables

The tone arm cable used in production units is 200 cm long and exhibits a capacitance of 210 pF per channel. If the pickup cartridge employed requires a low termination capacitance, suitable low-capacitance cables can be supplied. However, since the capacitance per unit length of cable is constant, it is often more convenient to shorten the standard cable to lower the capacitance appropriately. The internal tone arm capacitance of 20 pF and the input capacitance of the phono preamplifier must be subtracted from the desired capacitance value in calculating the required cable length.

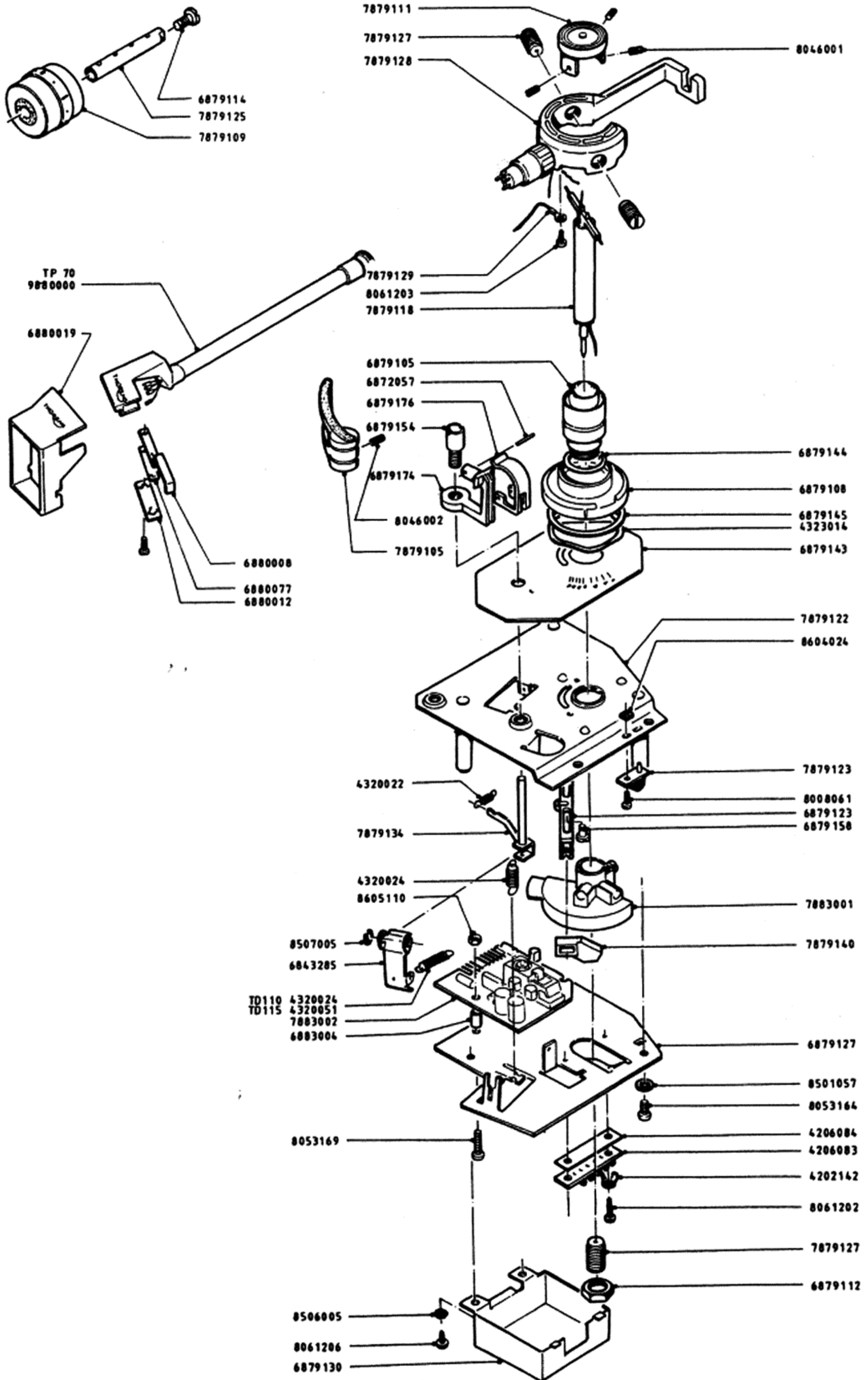

LIST OF SPARE PARTS – TONE ARM

4202142	Solder lug
4206083	Miniature terminal strip
4206084	Covering strip
4320022	Tension spring
4320024	Tension spring
4320051	Tension spring
4323014	Spring washer
6872057	Pivot pin
6879105	Turret
6879108	Antiskating ring
6879112	Hexagonal nut
6879114	Securing screw
6879123	Guide
6879127	Lower plate
6879130	Cover
6879143	Panel
6879144	Washer
6879145	Washer
6879154	Lift sleeve
6879158	Guide screw
6879174	Tone arm rest
6879176	Platform clasp
6880008	Handle
6880012	Guide spacer
6880019	Mounting gauge
6880077	Spacer
6883004	Spacer
7879105	Tone arm platform
7879109	Counterweight
7879111	Bearing ring
7879118	Horizontal shaft
7879122	Upper plate
7879123	Magnet holder 3
7879125	Guide
7879127	Bearing screw

7879128	Frame assembly
7879129	Grounding lead
7879134	Lift shaft
7879140	Magnet holder 1
7883001	Shutter/holder 2
7883002	Auto-stop board
8046001	Allen screw DIN 916 AM 3 x 4
8046002	Allen screw DIN 916 AM 3 x 5
8008061	Screw DIN 84 M 2.5 x 5
8053164	Screw DIN 7985 M 3 x 6
8053169	Screw DIN 7985 M 3 x 16
8061202	Screw DIN 7981 B 2.2 x 6.5
8061203	Screw DIN 7981 B 2.2 x 9.5
8061206	Screw DIN 7981 B 2.9 x 6.5
8501057	Washer DIN 125 A 3.2
8506005	Tooth washer DIN 6797 3.2
8507005	Clip washer DIN 6799 2.3
8604024	Nut DIN 562 M 2.5
8605110	Nut DIN 934 M 3
9880000	TP 70 cartridge wand
9879000	TP 30 bearing assembly TD 110
9883000	TP 30 bearing assembly TD 115

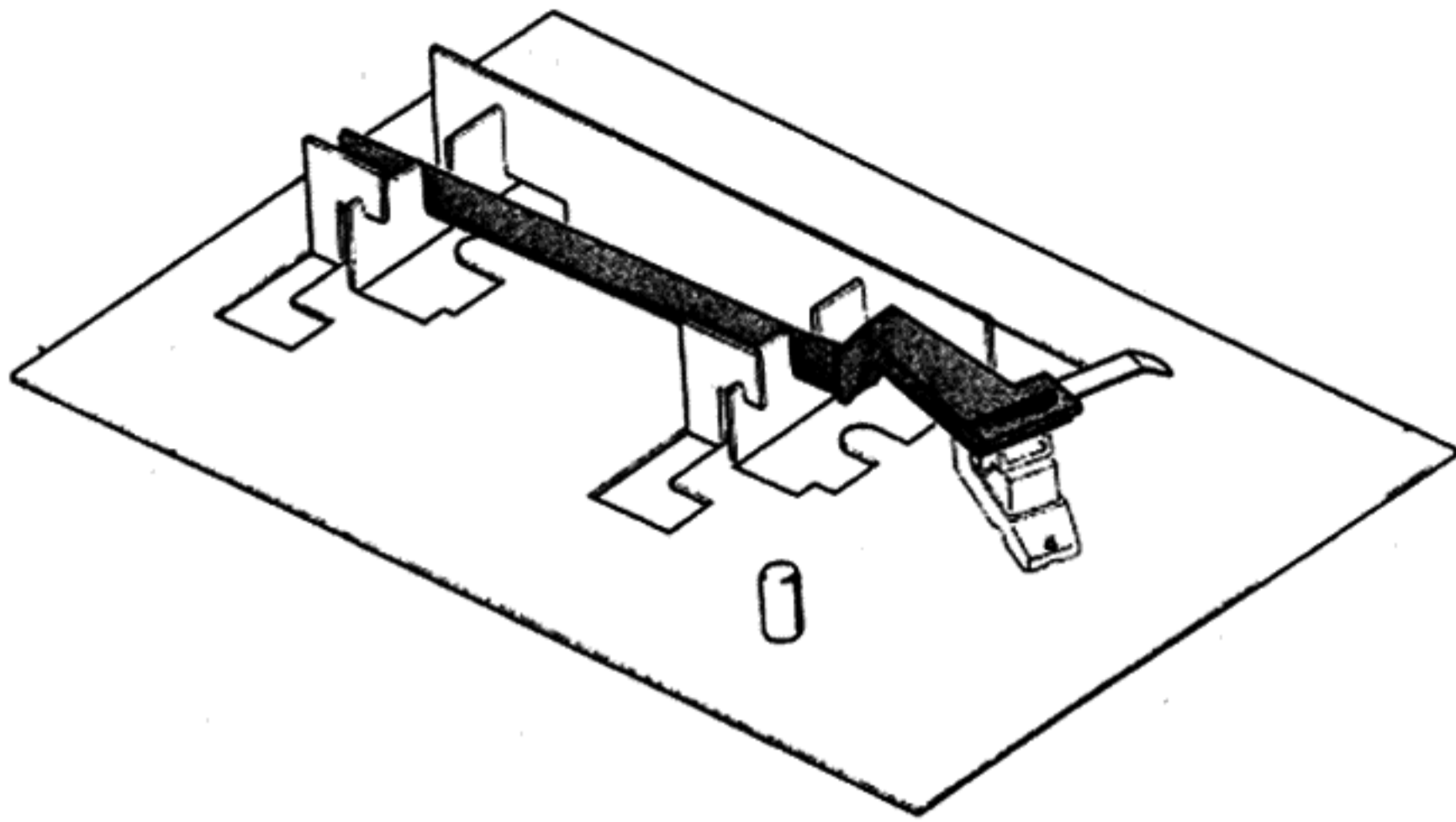

THORENS

TP 30 + TP 70

TP 22 + TP 63

THORENS

THORENS - FRANZ AG
CH - 5430 WETTINGEN
SWITZERLAND