

TASCAM

TEAC Professional Division

IF-88AE

Digital Audio Interface Unit



OWNER'S MANUAL

5700144900



CAUTION
RISK OF ELECTRIC SHOCK
DO NOT OPEN



CAUTION: TO REDUCE THE RISK OF ELECTRIC SHOCK, DO NOT REMOVE COVER (OR BACK). NO USER-SERVICEABLE PARTS INSIDE. REFER SERVICING TO QUALIFIED SERVICE PERSONNEL.



The lightning flash with arrowhead symbol, within an equilateral triangle, is intended to alert the user to the presence of uninsulated "dangerous voltage" within the product's enclosure that may be of sufficient magnitude to constitute a risk of electric shock to persons.



The exclamation point within an equilateral triangle is intended to alert the user to the presence of important operating and maintenance (servicing) instructions in the literature accompanying the appliance.

This appliance has a serial number located on the rear panel. Please record the model number and serial number and retain them for your records.
Model number _____
Serial number _____

WARNING: TO PREVENT FIRE OR SHOCK HAZARD, DO NOT EXPOSE THIS APPLIANCE TO RAIN OR MOISTURE.

NOTE FOR U.K. CUSTOMERS

DO NOT cut off the mains plug from this equipment. If the plug fitted is not suitable for the power points in your home or the cable is too short to reach a power point, then obtain an appropriate safety approved extension lead or consult your dealer.

If nonetheless the mains plug is cut off, remove the fuse and dispose of the plug immediately, to avoid a possible shock hazard by inadvertent connection to the mains supply.

If this product is not provided with a mains plug, or one has to be fitted, then follow the instructions given below:

IMPORTANT: The wires in this mains lead are coloured in accordance with the following code:

- GREEN-AND-YELLOW : EARTH
- BLUE : NEUTRAL
- BROWN : LIVE

WARNING: This apparatus must be earthed.

As the colours of the wires in the mains lead of this apparatus may not correspond with the coloured markings identifying the terminals in your plug proceed as follows.

The wire which is coloured GREEN-and-YELLOW must be connected to the terminal in the plug which is marked by the letter E or by the safety earth symbol \perp or coloured GREEN or GREEN-and-YELLOW.

The wire which is coloured BLUE must be connected to the terminal which is marked with the letter N or coloured BLACK.

The wire which is coloured BROWN must be connected to the terminal which is marked with the letter L or coloured RED.

When replacing the fuse only a correctly rated approved type should be used and be sure to re-fit the fuse cover.

IF IN DOUBT — CONSULT A COMPETENT ELECTRICIAN.

THE APPLIANCE CONFORMS WITH EEC DIRECTIVE 87/308/EEC REGARDING INTERFERENCE SUPPRESSION

CONFORME AL D.M. 13 APRILE 1989 DIRETTIVA CEE/87/308

The IF-88AE is . . .

The IF-88AE is an interface unit which allows transferring audio material between the TASCAM DA-88 Digital Multitrack Recorder and any units conforming to AES/EBU or SPDIF interface standard.

The package contains the following (1 per item) :

- IF-88AE Unit
- AC Power Cord
- PW-88D Cable
- BNC Cable
- Rack Mount Screw Kit
- Owner's Manual
- Warranty Card

To cascade multiple DA-88s, you need the optional PW-88S cable or cables (see diagram on page 10).

Table of Contents

The IF-88AE is	3
Specifications	3
Features and Controls	4
Operation	5
Transferring Signal between DA-88 and Units with "AES/EBU" Interface	5
Transferring Signal between DA-88 and Units with "SPDIF" Interface	7
Other Applications	9
Using CD and DAT Together	9
Transferring Signal from a Unit with "AES/EBU" I/O to Multiple DA-88s	10
Digital Bouncing within the DA-88	11
Transferring Signal between the DA-88 and Multiple Units with "AES/EBU" I/O	13
Converting "SPDIF" Signal into "AES/EBU" Format (available only upon request)	14
Using the ASSIGN Switches	14
Interfacing Units with AES/EBU Outputs to DA-88	14
Interfacing Units with SPDIF Outputs to DA-88	15
Interfacing DA-88 to Units with AES/EBU Inputs	16
Interfacing DA-88 to Units with SPDIF Inputs	16

The AES/EBU interface standard is for communicating data between professional digital units (such as CD players, DAT recorders, digital mixers).

The SPDIF (for Sony Philips Digital Interface Format) is an interface standard developed jointly by Sony and Philips with consumer applications in mind.

Specifications

Inputs/Outputs

AES/EBU:

Input (XLR3-31) x4 Conforms to IEC 958

Output (XLR3-32) x4 same as above

SPDIF:

Input (RCA) x1 same as above

Output (RCA) x1 same as above

TDIF-1 I/O (25 pin D-Sub)

WORD SYNC OUT (BNC): TTL level, 75 ohms

Power Source

USA/CANADA: 120 V AC, 60 Hz

EUROPE: 230 V AC, 50 Hz

U.K./AUSTRALIA: 240 V AC, 50 Hz

Power Consumption: 4 Watts

Dimensions (WxHxD): 19" x 1-7/8" x 7-11/16"
(482 mm x 48 mm x 195 mm) (see also drawing below)

Weight: 6-3/16 lbs. (2.8 kg)

Changes in specifications and features may be made without notice or obligation.

Dimensional Drawings

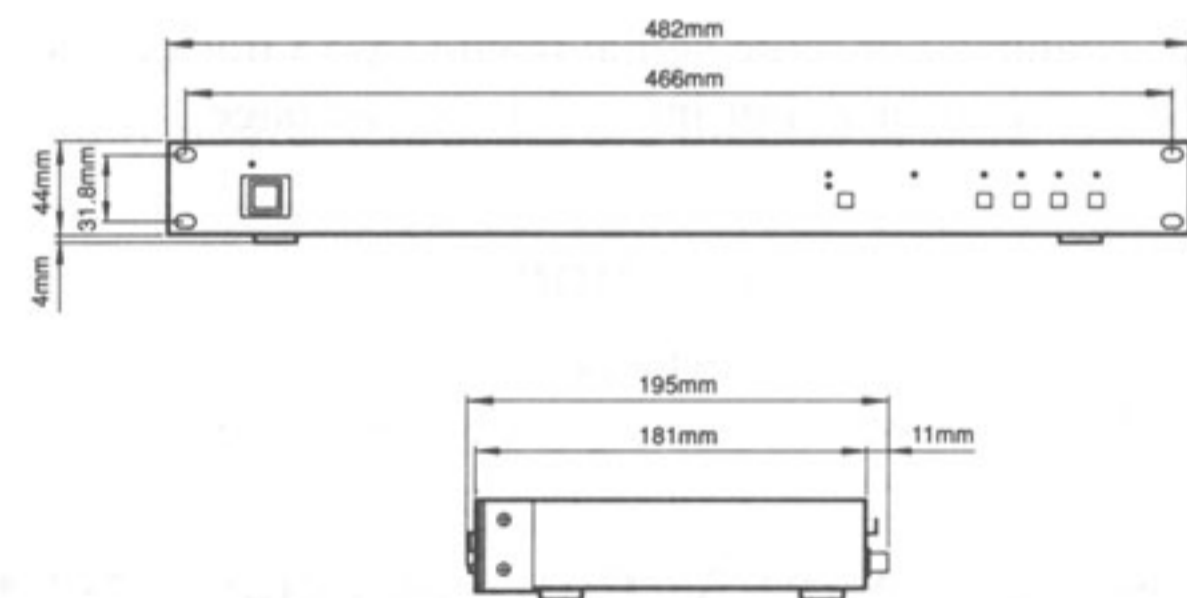

Features and Controls

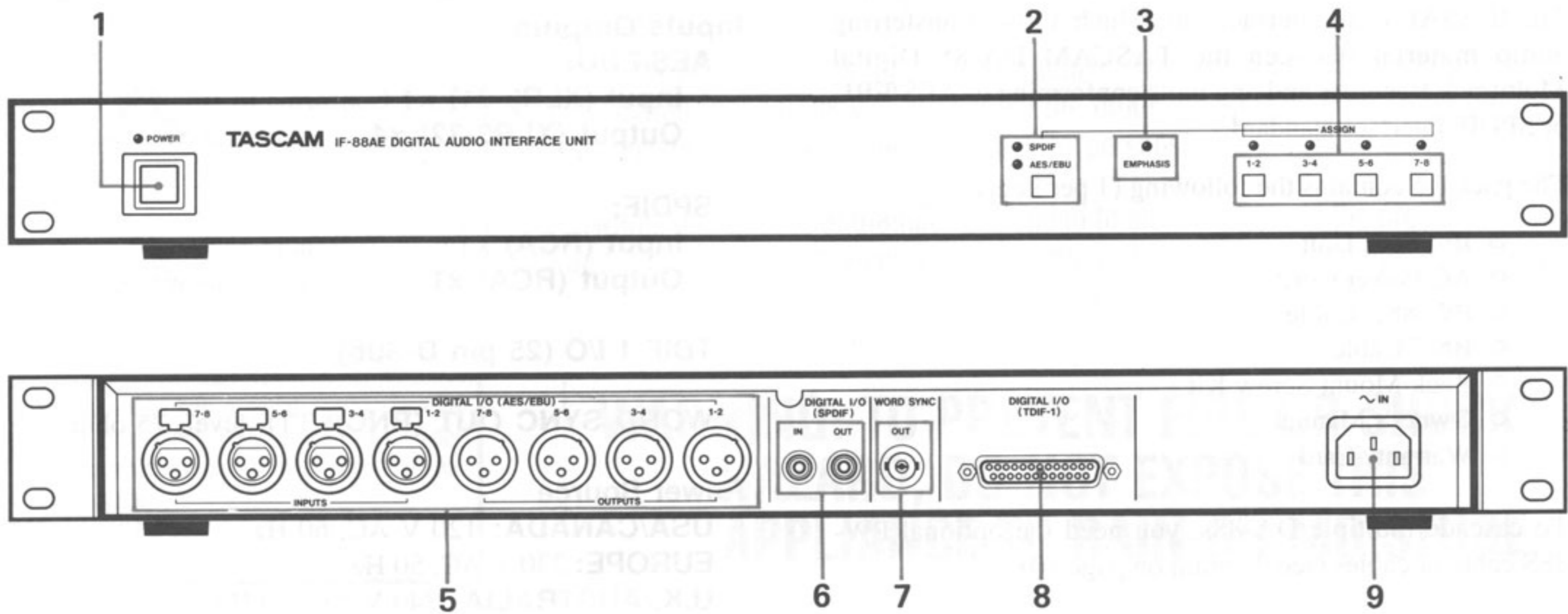

1. POWER switch : Switches on power to the unit.

2. Format Select switch : Setting this switch to SPDIF converts SPDIF signals into TDIF, or vice versa. The AES/EBU position allows converting AES/EBU format signals into TDIF, or vice versa.

TDIF is for TEAC Digital Interface Format.

3. EMPHASIS indicator : Lights, when the DA-88 is playing back a tape, to show the tape is high-emphasized as it was when originally recorded.

4. ASSIGN switches : Route signal from units with SPDIF or AES/EBU interface to DA-88 tracks over the desired channels; or route signal from DA-88 tracks to units with SPDIF interface. For more details, see page 14.

CAUTION

To prevent "clicks" don't operate the Format Select and ASSIGN switches during record/playback.

5. DIGITAL I/O (AES/EBU) connectors, 1-2 to 7-8 : These XLR-type connectors are for connecting to machines conforming to AES/EBU interface standard. The INPUTS accept both professional and consumer format data, while the OUTPUTS transmit only professional format data.

6. DIGITAL I/O (SPDIF) connectors : These RCA jacks are for connecting to machines conforming to SPDIF standard.

7. WORD SYNC OUT jack : For connecting to the WORD SYNC IN jack of the DA-88 when this is used as slave.

8. DIGITAL I/O (TDIF-1) connector : For connecting to the TDIF-1 port on the back of the DA-88 by means of the provided PW-88D cable.

9. ~ IN : The provided power cord is connected here.

Bescheinigung des Herstellers/Importeurs

Hiermit wird bescheinigt, daß der/die/das

IF-88AE Schnittstelle

(Gerät, Typ, Bezeichnung)

in Übereinstimmung mit den Bestimmungen der

AMTSBLATT 163/1984, VFG 1045/1984, VFG 1046/1984

(Amtsblattverfügung)

funk-entstört ist.

Der Deutschen Bundespost wurde das Inverkehrbringen dieses Gerätes angezeigt und die Berechtigung zur Überprüfung der Serie auf Einhaltung der Bestimmungen eingeräumt.

TEAC CORPORATION

Name des Herstellers/Importeurs

Operation

☞ Before attempting any cable connections, make sure all units involved in your system are turned off.

TRANSFERRING SIGNAL BETWEEN DA-88 AND UNITS WITH "AES/EBU" INTERFACE

☐ DA-88 as Recording Machine

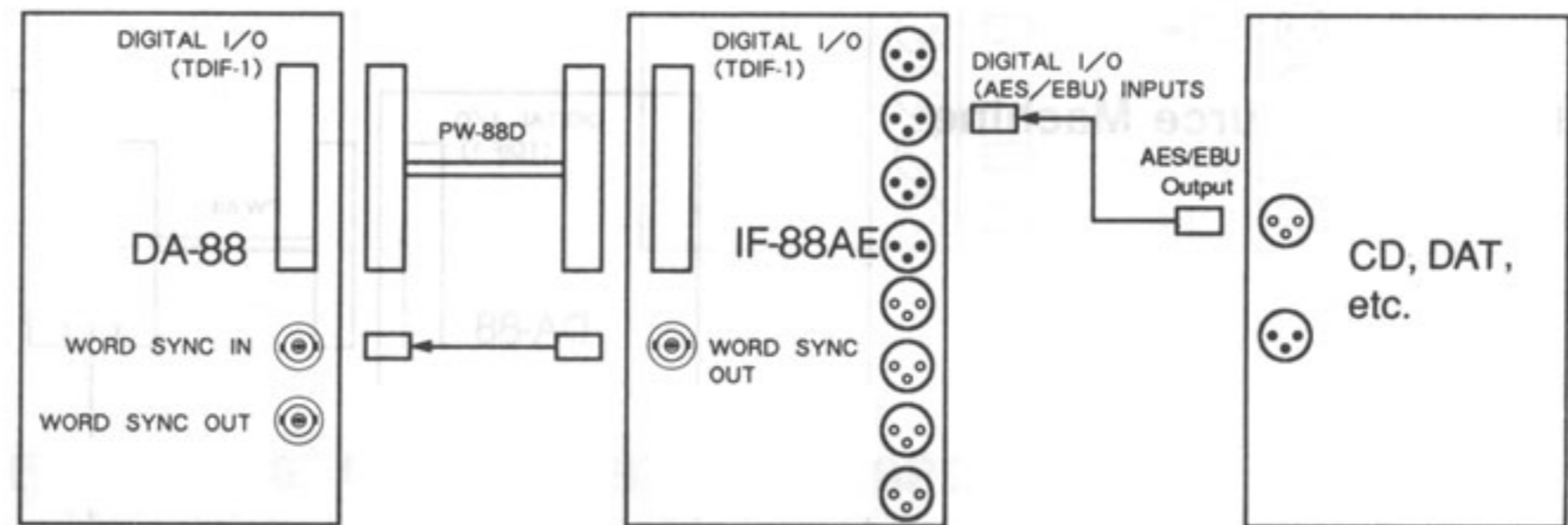

You can selectively route signal to DA-88 tracks by means of the ASSIGN switches.

1. Connect the provided PW-88D cable to the TDIF-1 port on the back of the DA-88, and the other end of the cable to the TDIF-1 port on the back of the IF-88AE.
2. Connect the provided BNC cable to the WORD SYNC IN jack on the back of the DA-88, and the other end of the cable to the WORD SYNC OUT jack on the back of the IF-88AE.
3. Using an appropriate cable, connect the AES/EBU output of your source unit (CD, DAT, etc) to the AES/EBU INPUT "1-2" connector on the back of the IF-88AE unit.

☞ Signals plugged into any other AES/EBU inputs don't pass through any ASSIGN switches (e.g. signal plugged into the 3-4 input goes only to DA-88 tracks 3 and 4 whether any ASSIGN switches are pressed or not).

4. Switch on power to the DA-88.
5. Switch on power to the IF-88AE.
6. Set the **Format Select** switch to its **AES/EBU** position.
7. Press the same numbered **ASSIGN** switch as the DA-88 tracks you want to route the signal to.

Whether to record on two tracks or a single track is up to the settings of the REC FUNCTION switches on the DA-88.

☞ You cannot press two or more ASSIGN switches at one time.

8. Switch on power to your source unit, and put it into its Internal Clock mode.

9. On the part of the DA-88, press the **DIGITAL IN** switch, and press the **CLOCK** switch until the WORD LED lights.

10. Follow the same procedure as for normal digital audio recording.

There's no need to dispatch the WORD SYNC connection when you use the DA-88 as the source machine ; you'll simply switch the DA-88 from Word to Internal clock.

□ **DA-88 as Source Machine**

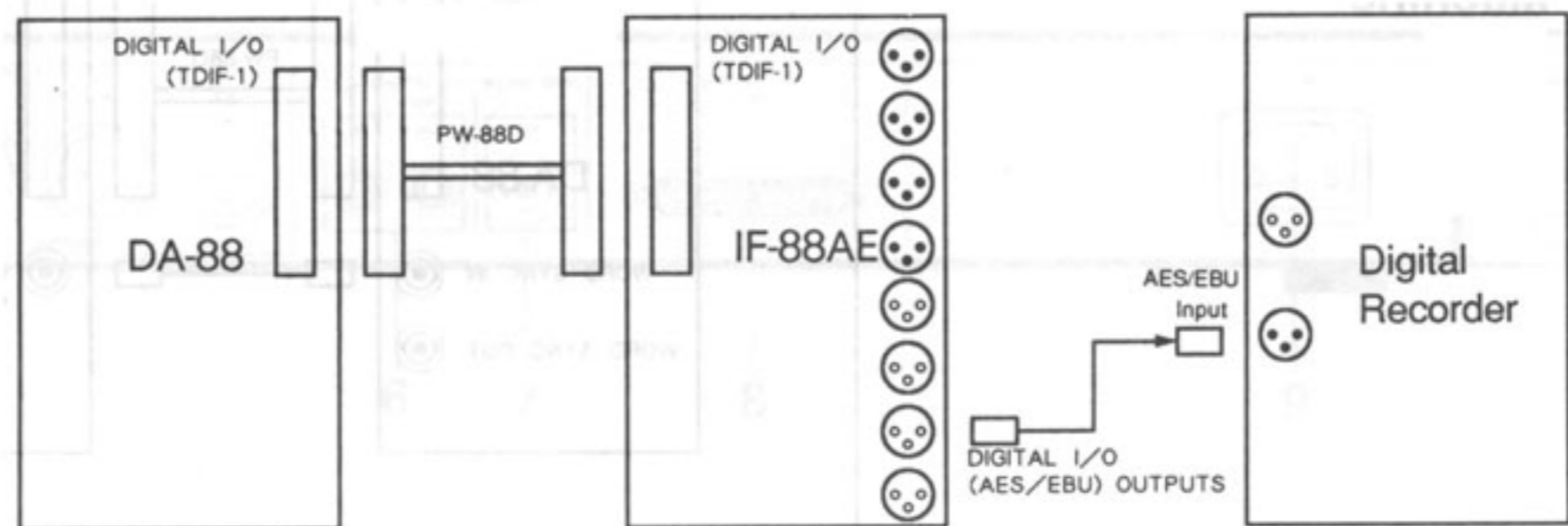

1. Connect the provided PW-88D cable to the TDIF-1 port on the back of the DA-88, and the other end of the cable to the TDIF-1 port on the back of the IF-88AE.

2. Using an appropriate cable, connect the desired AES/EBU OUTPUT of the IF-88AE to the AES/EBU input of your recording machine.

In this case, the ASSIGN switches have nothing to do with; DA-88 tracks 1 and 2 go to the AES/EBU 1-2 OUTPUT connector on the back of the IF-88AE, tracks 3 and 4 to the 3-4 OUTPUT connector, and so on.

3. Switch on power to the DA-88, and press its **CLOCK** switch until the associated INT LED lights.

4. Switch on power to the IF-88AE, and press its **Format Select** switch to its **AES/EBU** position.

5. Switch on power to the recording machine, and switch it to its Digital Input mode.

6. Follow the same procedure as for normal digital recording.

THIS DIGITAL APPARATUS DOES NOT EXCEED THE CLASS B LIMITS FOR RADIO NOISE EMISSIONS FROM DIGITAL APPARATUS AS SET OUT IN THE RADIO INTERFERENCE REGULATIONS OF THE CANADIAN DEPARTMENT OF COMMUNICATIONS.

LE PRESENT APPAREIL NUMERIQUE N'EMET PAS DE BRUITS RADIOELECTRIQUES DEPASANT LES LIMITES APPLICABLES AUX APPAREILS NUMERIQUE DE CLASSE B PRESCRITES DANS LE REGLEMENT SUR LE BROUILLAGES RADIOELECTRIQUE EDICTE PAR LE MINISTERE DES COMMUNICATIONS DU CANADA.

Routing DA-88 Tracks to Units with Multiple Digital Inputs (such as digital mixers)

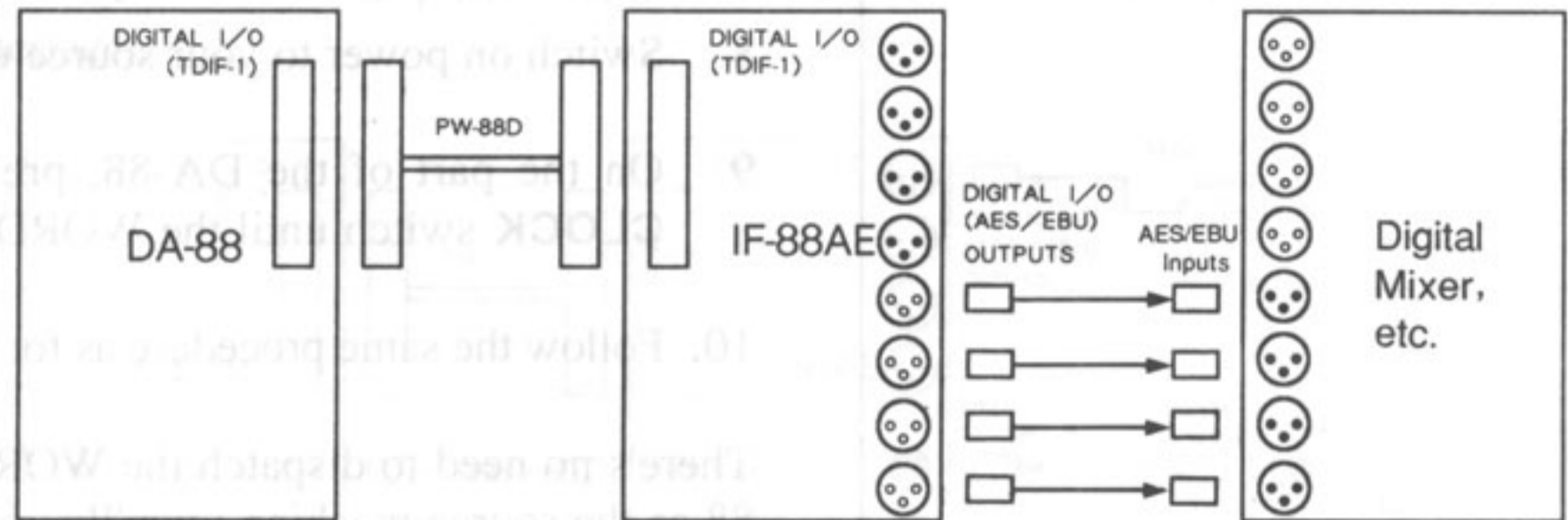

TRANSFERRING SIGNAL BETWEEN DA-88 AND UNITS WITH "SPDIF" INTERFACE

□ **DA-88 as Recording Machine**

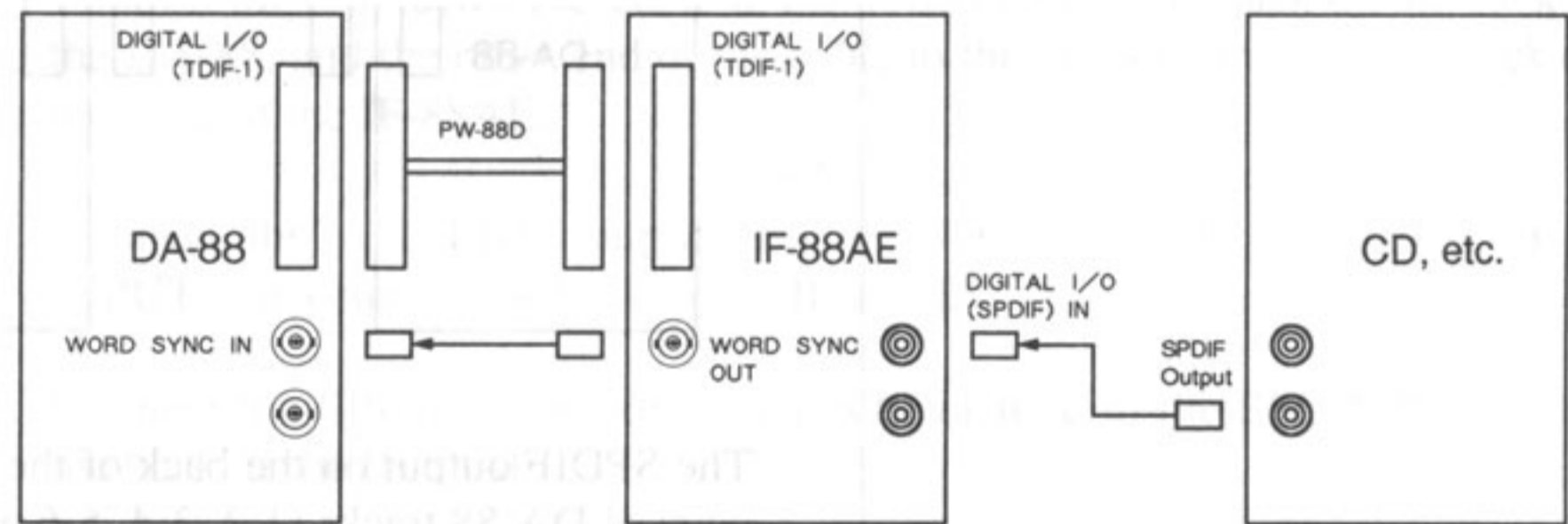

Signal from your source machine can selectively be routed to DA-88 tracks by means of the ASSIGN switches.

1. Connect the provided PW-88D cable to the TDIF-1 port on the back of the DA-88, and the other end of the cable to the TDIF-1 port on the back of the IF-88AE.
2. Connect the provided BNC cable to the WORD SYNC IN jack on the back of the DA-88, and the other end of the cable to the WORD SYNC OUT jack on the back of the IF-88AE.
3. Connect an appropriate cable to the SPDIF IN jack on the back of the IF-88AE, and the other end of the cable to the SPDIF output jack on your CD player or other source units.
4. Switch on power to the DA-88.
5. Switch on power to the IF-88AE.
6. Set the **Format Select** switch on the IF-88AE to its **SPDIF** position.

7. Press the desired **ASSIGN** switch (one at a time). Example : If you press the **ASSIGN 3-4** switch, signal is routed to DA-88 tracks 3 and 4 (or to either track, as selected by the **REC FUNCTION** switches on the DA-88).
8. Switch on power to your source unit, and reference this to its internal clock.
9. On the part of the DA-88, press the **DIGITAL IN** switch, and press the **CLOCK** switch until the **WORD LED** lights.
10. Follow the same procedure as for normal digital audio recording.

There's no need to dispatch the **WORD SYNC** connection when you use the DA-88 as the source machine ; you'll simply switch the DA-88 from Word to Internal clock.

□ DA-88 as Source Machine

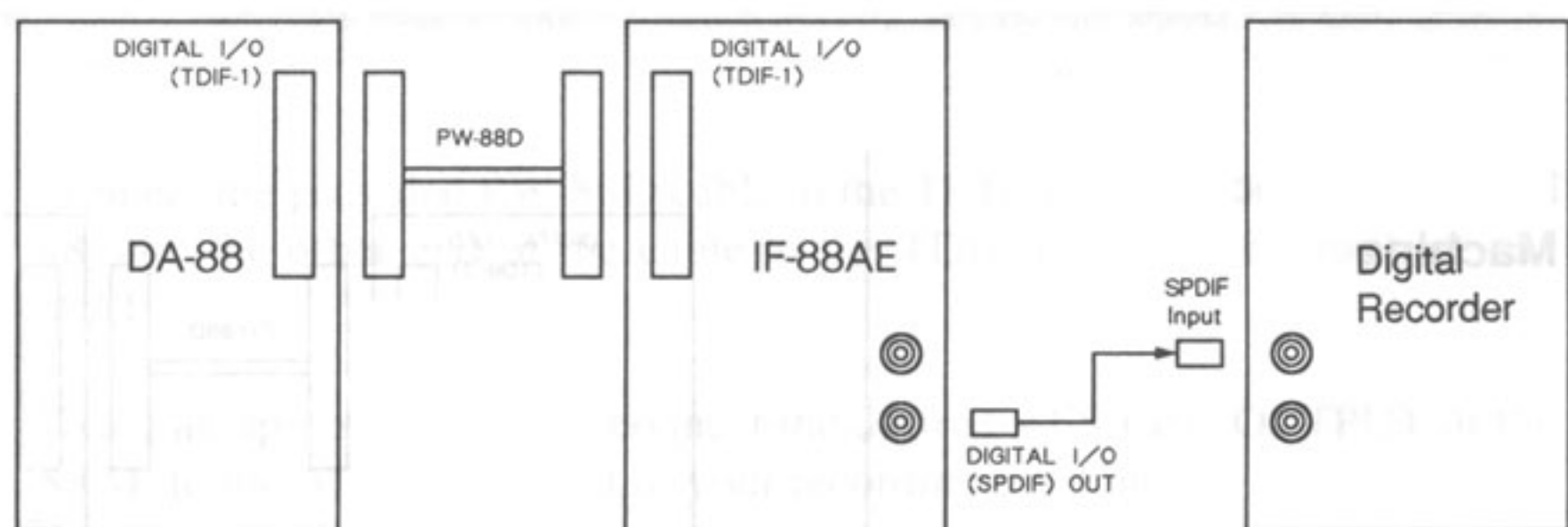

The SPDIF output on the back of the IF-88AE can be fed with any one of the four pairs of DA-88 tracks (1-2, 3-4, 5-6 or 7-8) as selected by the **ASSIGN** switches.

1. Connect the provided PW-88D cable to the TDIF-1 port on the back of the DA-88, and the other end of the cable to the TDIF-1 port on the back of the IF-88AE.
2. Using an appropriate cable, establish connection between the SPDIF OUT jack of the IF-88AE and the SPDIF input jack of your recording machine.
3. Switch on power to the DA-88, and press its **CLOCK** switch until the associated **INT LED** lights.
4. Switch on power to the IF-88AE.
5. Set the **Format Select** switch to its **SPDIF** position, and press the **ASSIGN 1-2** switch to route DA-88 tracks 1 and 2 to the recording machine, or the **3-4** switch to route tracks 3 and 4, and so on. (You can press only one **ASSIGN** switch at a time.)
6. Switch on power to your recording machine, and put it into Digital Input mode.
7. Follow the same procedure as for normal digital audio recording.

Other Applications

USING CD AND DAT TOGETHER

Here we'll use a CD player with AES/EBU interface and a DAT with SPDIF interface.

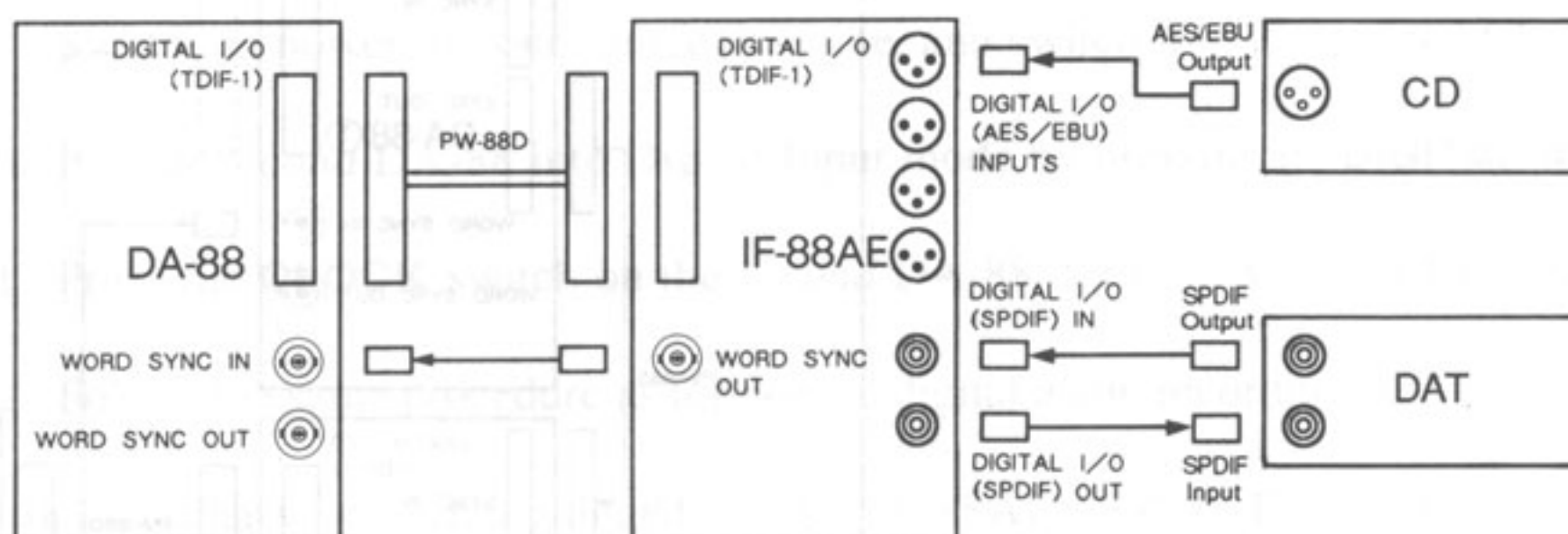

□ Routing Signal from CD or DAT to DA-88

1. Connect the provided PW-88D cable to the TDIF-1 port on the back of the DA-88, and the other end of the cable to the TDIF-1 port on the back of the IF-88AE.
2. Connect the provided BNC cable to the WORD SYNC IN jack on the back of the DA-88, and the other end of the cable to the WORD SYNC OUT jack on the back of the IF-88AE.
3. Connect the AES/EBU output of your CD unit to the AES/EBU "1-2" INPUT connector on the back of the IF-88AE.
4. Connect the SPDIF output of your DAT machine to the SPDIF IN jack on the back of the IF-88AE.
5. Switch on power to the DA-88.
6. Switch on power to the IF-88AE.
7. If you intend to route the CD output to the DA-88, set the **Format Select** switch to **AES/EBU**.
If you intend to route the DAT output to the DA-88, set the **Format Select** switch to **SPDIF**.
8. Press one of the four **ASSIGN** switches. Signal from CD or DAT will be routed to the same numbered DA-88 tracks as the switch pressed.
9. Switch on power to the source unit (CD or DAT), and reference it to its **Internal Clock**.
10. On the part of the DA-88, press the **DIGITAL IN** switch, and press the **CLOCK** switch until the WORD LED lights.
11. Follow the same procedure as for normal digital audio recording.

□ Routing Signal from DA-88 to DAT

If you connect the IF-88AE's SPDIF OUT to your DAT's SPDIF input, you can record DA-88 tracks to DAT.

TRANSFERRING SIGNAL FROM A UNIT WITH "AES/EBU" I/O TO MULTIPLE DA-88S

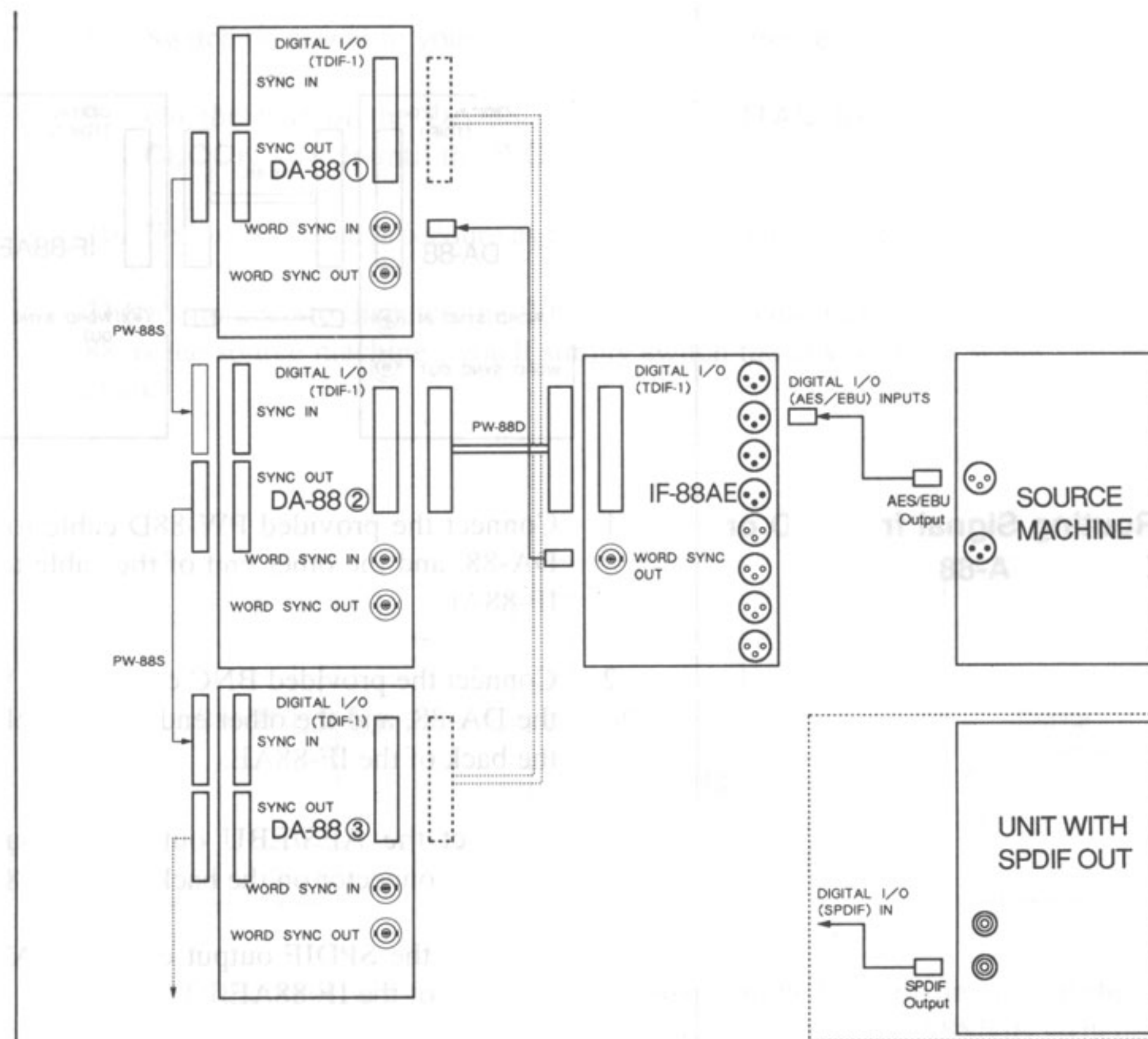

1. Use the optional PW-88S cables, cascade your DA-88s by connecting SYNC OUT of the first DA-88 to SYNC IN of the second DA-88, and connect SYNC OUT of the second to SYNC IN of the third, and so on, as shown.

CAUTION

Use only the PW-88S cable. The use of any other cables may *seriously damage* the DA-88 circuitry.

2. Connect the provided BNC cable to the WORD SYNC OUT jack on the back of the IF-88AE, and the other end of the cable to the WORD SYNC IN jack on the back of the first DA-88.
3. Connect the provided PW-88D cable to the TDIF-1 port on the back of the *second* DA-88, and the other end of the cable to the TDIF-1 port on the back of the IF-88AE.
4. Using an appropriate cable, connect the source machine's AES/EBU output to the IF-88AE's AES/EBU "1-2" INPUT.
5. Switch on power to the DA-88s.
6. Switch on power to the IF-88AE.

7. Set the **Format Select** switch to its **AES/EBU** position.
 8. Press the desired one of the four **ASSIGN** switches. The same numbered DA-88 tracks as the switch pressed will be fed with signal plugged into the IF-88AE's AES/EBU "1-2" INPUT.
 9. Switch on power to your source machine, and switch it to its Internal Clock.
 10. Put the *second* DA-88 into Digital Input mode by pressing its **DIGITAL IN**.
 11. Press the **CLOCK** switch on the *second* DA-88 until its WORD LED lights.
 12. Follow the same procedure as for normal digital audio recording.
- In a similar way, signal plugged into the IF-88AE's SPDIF IN can be routed to multiple DA-88s.

DIGITAL BOUNCING WITHIN THE DA-88

Bouncing here is limited to from a pair of tracks to another pair of tracks (i.e. from tracks 1 and 2 to tracks 3 and 4, etc), and an odd-numbered track is recorded to another odd-numbered track, and an even-numbered track is recorded to another even-numbered track (e.g. track 1 can be recorded to track 3, 5 or 7, but not to track 2, 4, 6 or 8); you cannot combine (mix) tracks into one.

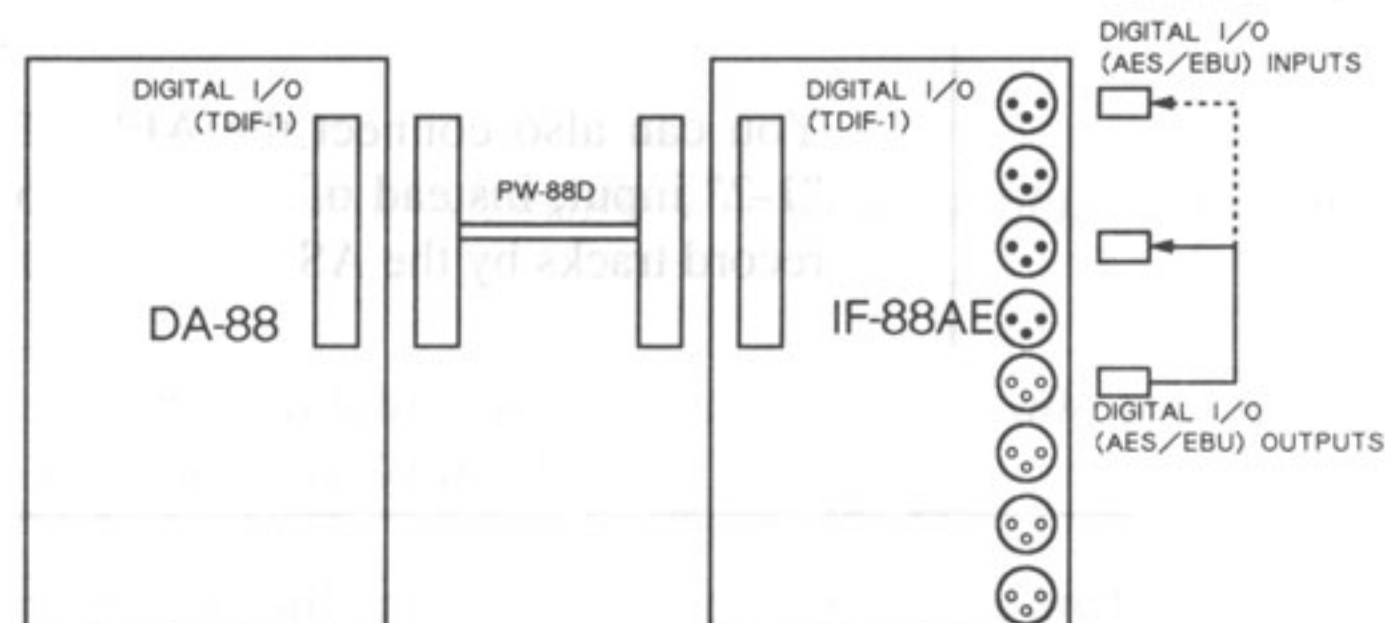

As an example, we'll bounce track 1 to track 5, and track 2 to track 6.

First, make sure both the DA-88 and the IF-88AE are not turned on yet.

1. Connect the provided PW-88D cable to the TDIF-1 port on the back of the DA-88, and the other end of the cable to the TDIF-1 port on the back of the IF-88AE.
2. Connect an appropriate cable to the AES/EBU OUTPUT 1-2 connector on the back of the IF-88AE, and the other end of the cable to the nearby INPUT 5-6 connector on the same unit.
3. Switch on power to the DA-88, and press its **CLOCK** switch to let the associated INT LED light up.
4. Switch on power to the IF-88AE.

5. On the part of the DA-88, enter the delay time of -3 samples (Fs) for the source tracks (1 and 2 in our example) as follows :

(1) Hold down the increment (▲) key and press the **DIGITAL IN** switch. "DIGITAL" will flash once in the display window, the DA-88 going into its Digital Output mode.

(2) Press **REC FUNCTION** for track 1. The display will look like "tr.1 00 00."

(3) Use the ▼ and ▲ keys to let the display read "-003."

(4) In a similar way, enter a -3 sample delay time for track 2 as well.

If you don't enter a -3 sample delay time (= 3 sample advance time) for the source tracks, the bounced tracks (5 and 6 in our example) will lag by 3 samples behind other tracks when played back.

6. Put the DA-88 into Digital Input mode by means of the **DIGITAL IN** switch.

7. Put tracks 5 and 6 into Record Ready mode by pressing their **REC FUNCTION** switch. Make sure all other tracks are in Safety mode, especially tracks 1 and 2.

If you put only one track into Ready mode, for example, track 6, only track 2 will be bounced there.

8. To start bouncing, hold down **RECORD** and press **PLAY**.

☞ Track delay times are automatically put into a back-up memory. Clear them to 00 00 once bouncing is complete.

You can also connect the AES/EBU output from a pair of source tracks to the "1-2" input, instead of to input 5-6 in our example above, so that you can select record tracks by the ASSIGN switches.

For U.S.A.

TO THE USER

This equipment has been tested and found to comply with the limits for a Class B digital device, pursuant to Part 15 of the FCC Rules. These limits are designed to provide reasonable protection against interference in a residential area. This device generates and uses radio frequency energy and if not installed and used in accordance with the instructions, it may cause interference to radio or TV reception. If this unit does cause interference with TV or radio reception you can try to correct the interference by one or more of the following measures :

- a) Reorient or relocate the receiving antenna.
 - b) Increase the separation between the equipment and the receiver.
 - c) Plug the equipment into a different outlet so that it is not on the same circuit as the receiver.
- If necessary, consult the dealer or an experienced radio/TV technician for additional suggestions.

CAUTION

Changes or modifications to this equipment not expressly approved by TEAC CORPORATION for compliance could void the user's authority to operate this equipment.

TRANSFERRING SIGNAL BETWEEN THE DA-88 AND MULTIPLE UNITS WITH "AES/EBU" I/O

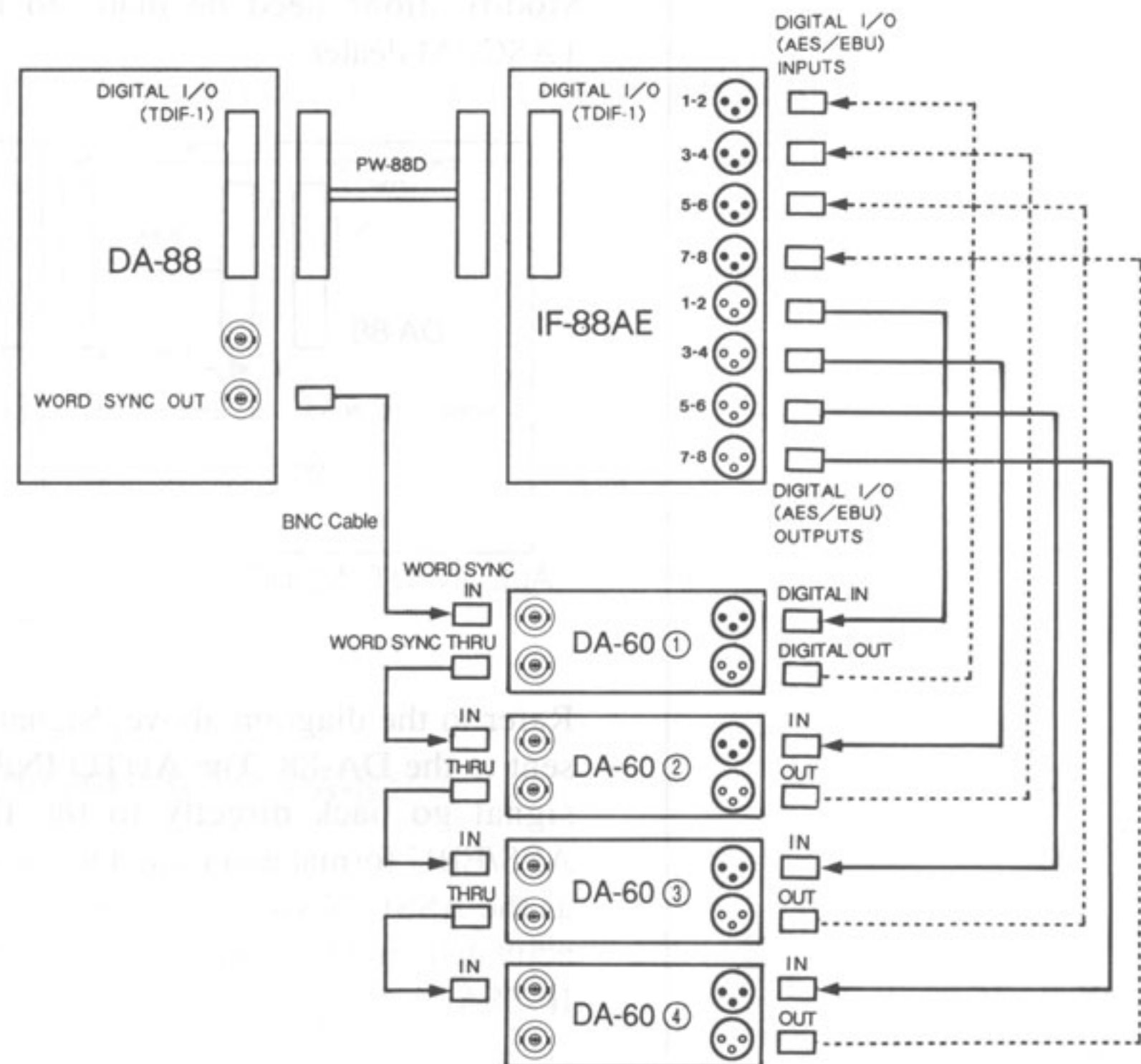

☞ Your unit with AES/EBU I/O must be able to be referenced to External Clock.

☞ You need additional BNC cables to cascade two or more DA-60s or other units with AES/EBU I/O.

1. Make sure all units involved in your system are turned off.
2. Connect the IF-88AE to the DA-88 and your units with AES/EBU I/O as shown.
3. Switch on power to the DA-88.
4. Switch on power to the IF-88AE.
5. Set the **Format Select** switch to **AES/EBU**.
6. Switch on power to your units with AES/EBU I/O, and set their Clocks to External.
7. You can now transfer data in either direction.

CONVERTING "SPDIF" SIGNAL INTO "AES/EBU" FORMAT
(Available Only Upon Request)

Modifications need be made to the IF-88AE circuits. Consult your nearest TASCAM dealer.

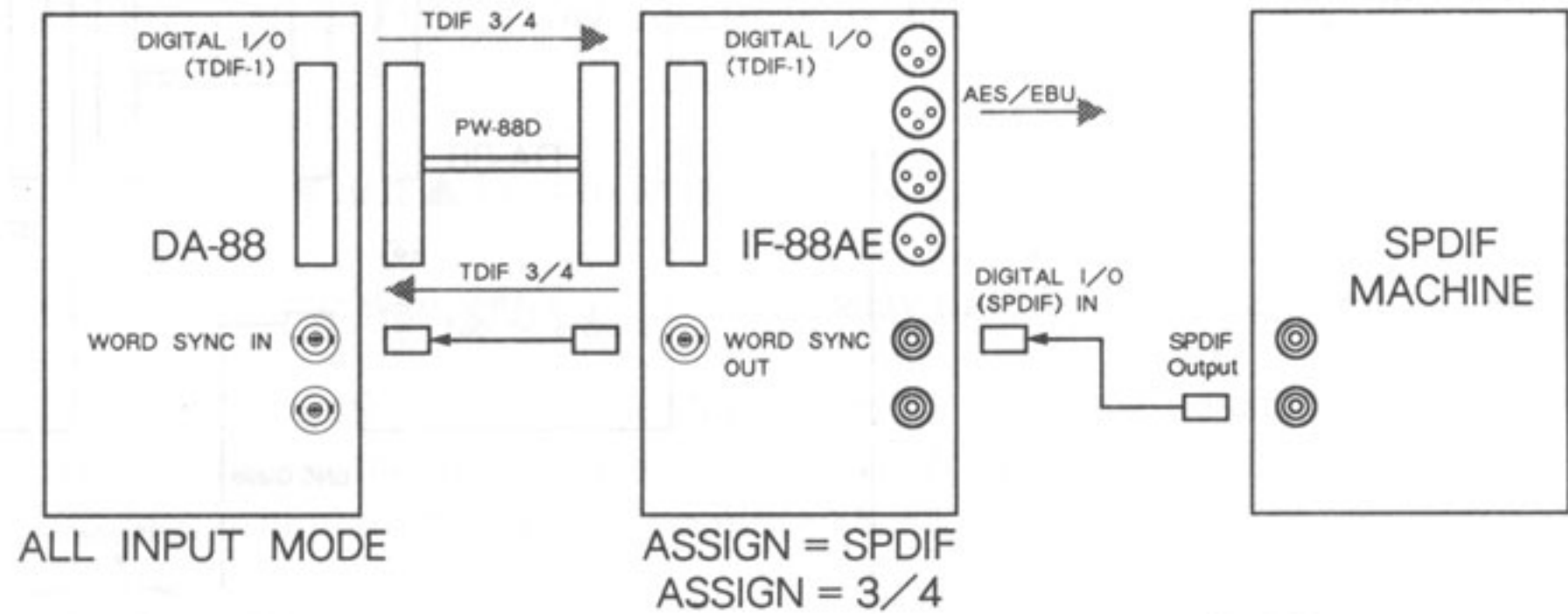

Refer to the diagram above. Signal fed into the SPDIF IN jack of the IF-88AE is sent to the DA-88. The AUTO INPUT mode of the DA-88 comes in, and lets the signal go back directly to the IF-88AE. The signal is then converted into AES/EBU format and routed to the same numbered AES/EBU OUTPUT connector as the ASSIGN switch pressed. The diagram supposes the ASSIGN 3- 4 switch is activated, and the signal is sent to the AES/EBU 3-4 OUTPUT on the back of the IF-88AE.

Using the ASSIGN Switches

Typically, the IF-88AE may be used to interface :

1. Units with AES/EBU outputs to DA-88,
2. Units with SPDIF outputs to DA-88,
3. DA-88 to units with AES/EBU inputs (in this case, the ASSIGN switch has nothing to do with), and
4. DA-88 to units with SPDIF inputs.

Accordingly, this section of the manual is divided into four subsections.

INTERFACING UNITS WITH AES/EBU OUTPUTS TO DA-88

Refer to the table below. Signal coming from an AES/EBU output of external units and plugged into the AES/EBU "1-2" INPUT connector on the back of the IF-88AE, is routed to the same numbered DA-88 tracks as the ASSIGN switch pressed (e.g. if the ASSIGN 3-4 switch is pressed, the AES/EBU 1-2 INPUT signal is sent to the DA-88's REC FUNCTION 3 and 4 switches and on to tracks 3 and 4).

You can press only one ASSIGN switch at one time.

Pressing none of the ASSIGN switches is equivalent to pressing the 1-2 switch ; there is no need for you to press the ASSIGN 1-2 switch to route the AES/EBU 1-2 INPUT signal to the DA-88's REC FUNCTION 1 and 2 switches.

The Format Select switch must be set to its AES/EBU position.

ASSIGN Sw. To DA-88 Trks	1-2	3-4	5-6	7-8
1-2	AES/EBU 1-2	AES/EBU 1-2	AES/EBU 1-2	AES/EBU 1-2
3-4	3-4	1-2	3-4	3-4
5-6	5-6	5-6	1-2	5-6
7-8	7-8	7-8	7-8	1-2

INTERFACING UNITS WITH SPDIF OUTPUTS TO DA-88

Refer to the table below. Signal coming from an SPDIF output of external units and plugged into the SPDIF IN jack on the back of the IF-88AE, is routed to the same numbered DA-88 tracks as the ASSIGN switch pressed (e.g. if the ASSIGN 1-2 switch is pressed, signal is sent to the DA-88's REC FUNCTION 1 and 2 switches and on to tracks 1 and 2).

You can press only one ASSIGN switch at one time.

The Format Select switch must be set to its SPDIF position.

If signal is plugged into any AES/EBU INPUTS other than the one which is numbered the same as the ASSIGN switch pressed, it is converted into TDIF and routed to the DA-88, as the table shows.

ASSIGN Sw. To DA-88 Trks	1-2	3-4	5-6	7-8
1-2	SPDIF IN	AES/EBU 1-2	AES/EBU 1-2	AES/EBU 1-2
3-4	AES/EBU 3-4	SPDIF IN	AES/EBU 3-4	AES/EBU 3-4
5-6	AES/EBU 5-6	AES/EBU 5-6	SPDIF IN	AES/EBU 5-6
7-8	AES/EBU 7-8	AES/EBU 7-8	AES/EBU 7-8	SPDIF IN

INTERFACING DA-88 TO UNITS WITH AES/EBU INPUTS

In this case, track signals from DA-88 are routed to the same numbered AES/EBU OUTPUTS as the tracks (i.e. tracks 1 and 2 are routed to the AES/EBU 1-2 OUTPUT, and so on), *regardless of the setting of the ASSIGN switches.*

The Format Select switch must be set to AES/EBU.

INTERFACING DA-88 TO UNITS WITH SPDIF INPUTS

In this case, the same numbered DA-88 tracks as the ASSIGN switch pressed are routed to the SPDIF OUT jack on the back of the IF-88AE (i.e. pressing the ASSIGN 1-2 switch is to select tracks 1 and 2, and so on).

You can press only one ASSIGN switch at one time.

The Format Select switch must be set to SPDIF.

Track signals not selected by the ASSIGN switches are converted into AES/EBU format and sent to the same numbered AES/EBU OUTPUT jacks (e.g. if the ASSIGN 1-2 switch is not pressed, tracks 1 and 2 are sent to the AES/EBU 1-2 OUTPUT connector).

From DA-88 Trks \ ASSIGN Sw.	1-2	3-4	5-6	7-8
1-2	SPDIF OUT	AES/EBU 1-2	AES/EBU 1-2	AES/EBU 1-2
3-4	AES/EBU 3-4	SPDIF OUT	AES/EBU 3-4	AES/EBU 3-4
5-6	AES/EBU 5-6	AES/EBU 5-6	SPDIF OUT	AES/EBU 5-6
7-8	AES/EBU 7-8	AES/EBU 7-8	AES/EBU 7-8	SPDIF OUT

TEAC CORPORATION

Musashino Center Bldg., 1-19-18, Nakacho, Musashino-shi, Tokyo 180, Japan Phone: (0422) 52-5081

TEAC AMERICA, INC.

7733 Telegraph Road, Montebello, California 90640 Phone: (213) 726-0303

TEAC CANADA LTD.

340 Brunel Road, Mississauga, Ontario L4Z 2C2, Canada Phone: 905-890-8008

TEAC UK LIMITED

5 Marlin House, Marlins Meadow, The Croxley Centre, Watford, Herts. WD1 8YA, U.K. Phone: 0923-819631

TEAC DEUTSCHLAND GmbH

Bahnstrasse 12, 65205 Wiesbaden-Erbenheim, Germany Phone: 0611-71580

TEAC FRANCE S.A.

17, Rue Alexis-de-Tocqueville, CE 005 92182 Antony Cedex, France Phone: (1) 42.37.01.02

TEAC BELGIUM NV/SA

143C Woluwelaan, 1831 Machelen-Diegem, Belgium Phone: (02) 725 6555

TEAC NEDERLAND BV

Perkinsbaan 11, 3439 ND Nieuwegein, Nederland Phone: 03-402-30229

TEAC AUSTRALIA PTY., LTD.
A.C.N. 005 408 462

106 Bay Street, Port Melbourne, Victoria 3207, Australia Phone: (03) 646-1733

TEAC ITALIANA S.p.A.

Via C. Cantù 5, 20092 Cinisello Balsamo, Milano, Italy Phone: 02-66010500