

CLASSIC® 30

SINGLE UNIT GUITAR AMPLIFIER

O P E R A T I N G G U I D E





Intended to alert the user to the presence of uninsulated “dangerous voltage” within the product’s enclosure that may be of sufficient magnitude to constitute a risk of electric shock to persons.



Intended to alert the user to the presence of important operating and maintenance (servicing) instructions in the literature accompanying the product.

CAUTION Risk of electrical shock — **DO NOT OPEN!**

CAUTION To reduce the risk of electric shock, do not remove cover. No user serviceable parts inside. Refer servicing to qualified service personnel.

WARNING To prevent electrical shock or fire hazard, do not expose this appliance to rain or moisture. Before using this appliance, read the operating guide for further warnings.



Este símbolo tiene el propósito de alertar al usuario de la presencia de “(voltaje) peligroso” que no tiene aislamiento dentro de la caja del producto que puede tener una magnitud suficiente como para constituir riesgo de corrientazo.



Este símbolo tiene el propósito de alertar al usuario de la presencia de instrucciones importantes sobre la operación y mantenimiento en la literatura que viene con el producto.

PRECAUCION Riesgo de corrientazo — No abra.

PRECAUCION Para disminuir el riesgo de corrientazo, no abra la cubierta. No hay piezas adentro que el usuario pueda reparar. Deje todo mantenimiento a los técnicos calificados.

ADVERTENCIA Para evitar corrientazos o peligro de incendio, no deje expuesto a la lluvia o humedad este aparato. Antes de usar este aparato, lea más advertencias en la guía de operación.



Ce symbole est utilisé pour indiquer à l'utilisateur la présence à l'intérieur de ce produit de tension non-isolée dangereuse pouvant être d'intensité suffisante pour constituer un risque de choc électrique.



Ce symbole est utilisé pour indiquer à l'utilisateur qu'il ou qu'elle trouvera d'importantes instructions sur l'utilisation et l'entretien (service) de l'appareil dans la littérature accompagnant le produit.

ATTENTION Risques de choc électrique — **NE PAS OUVRIR!**

ATTENTION Afin de réduire le risque de choc électrique, ne pas enlever le couvercle. Il ne se trouve à l'intérieur aucune pièce pouvant être réparée par l'utilisateur. Confier l'entretien à un personnel qualifié.

AVERTISSEMENT Afin de prévenir les risques de décharge électrique ou de feu, n'exposez pas cet appareil à la pluie ou à l'humidité. Avant d'utiliser cet appareil, lisez les avertissements supplémentaires situés dans le guide d'utilisation.



Dieses Symbol soll den Anwender vor unisolierten gefährlichen Spannungen innerhalb des Gehäuses warnen, die von Ausreichender Stärke sind, um einen elektrischen Schlag verursachen zu können.



Dieses Symbol soll den Benutzer auf wichtige Instruktionen in der Bedienungsanleitung aufmerksam machen, die Handhabung und Wartung des Produkts betreffen.

VORSICHT Risiko — Elektrischer Schlag! Nicht öffnen!

VORSICHT Um das Risiko eines elektrischen Schlages zu vermeiden, nicht die Abdeckung entfernen. Es befinden sich keine Teile darin, die vom Anwender repariert werden könnten. Reparaturen nur von qualifiziertem Fachpersonal durchführen lassen.

ACHTUNG Um einen elektrischen Schlag oder Feuergefahr zu vermeiden, sollte dieses Gerät nicht dem Regen oder Feuchtigkeit ausgesetzt werden. Vor Inbetriebnahme unbedingt die Bedienungsanleitung lesen.

Congratulations on your purchase of the Peavey Classic 30. This newest member of the Classic tube amp family uses the same basic preamp design as the Classic 50, with the addition of the boost switch from the very popular Classic 20. The 30-watt power amp, when combined with the specially-voiced 12" speaker, creates a very powerful amplifier that's portable enough for backstage or practice, yet loud enough to jam with a rhythm section. The dual channel preamp allows quick variation of tone—from vintage blues, to modern hard-rock and grunge tones. The boost switch is particularly useful in obtaining the more traditional “cranked-amp” tones without the harshness generated by sending too much low end to the power amp. The 30-watt power level is just the right amount for power amp chunk and sustain at a reasonable volume.

Two particularly modern additions to this amplifier are the reverb and effects loop. The reverb unit is the long-spring type found in most guitar amps since the 50s. The effects loop comes in especially handy when used with delay, chorus, and many other effects units, rack or stomp box—when you don't want the associated noise of connecting them in-line with the amp.

For a special treat, try plugging one of the Classic enclosures or even a 412-EVH 5150 cabinet into the external speaker jack. You'll find this particular combination has plenty of “knock” in the low-end. And best of all, it's very LOUD.

FEATURES

- All-tube preamp and power amp
- 30 W RMS into 16 or 8 ohms
- Tweed-covered cabinet with chrome chassis
- Lead and Normal channels: footswitchable
- 3-band vintage EQ
- External speaker capability
- Reverb with level control: footswitchable
- Effects loop
- Boost switch



The Peavey Classic® Series. To hear more, visit your local Peavey dealer.

ENGLISH

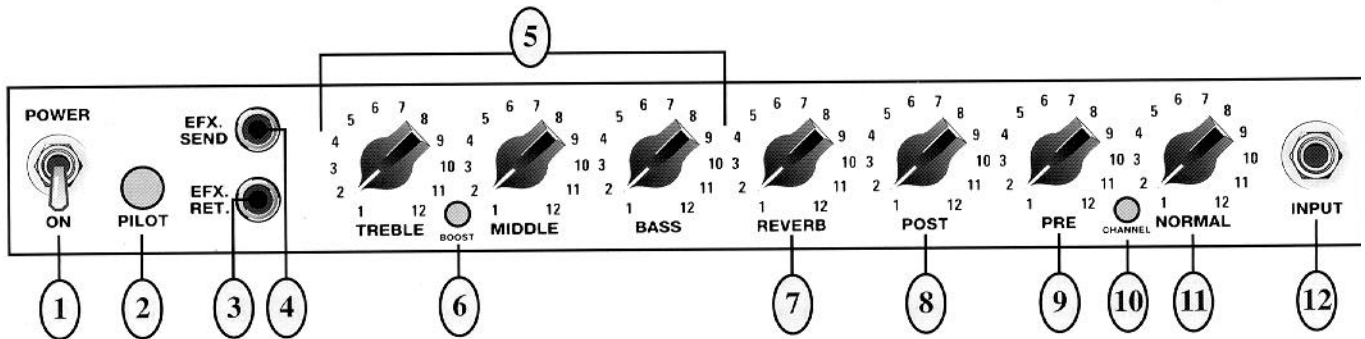

POWER SWITCH (1)

Switch to "on" position to activate.

PILOT LIGHT LED (2)

Illuminates when AC power is being supplied to the unit.

EFFECTS RETURN (3)

Input for returning signals from external effects or signal processing equipment.

EFFECTS SEND (4)

Output for supplying signal to external effects or signal processing equipment.

TREBLE, MIDDLE, AND BASS EQ (5)

Passive tone controls that regulate high, mid, and low frequencies, respectively.

BOOST SWITCH (6)

Boosts the overall system gain. Depress to the "in" position to activate.

REVERB (7)

Reverberation is an echo effect. Rotate clockwise to increase the effect. Remote footswitch can control on/off.

POST GAIN (8)

Controls the overall volume level of the Lead channel. The final level adjustment should be made after the desired sound has been achieved.

PRE GAIN (9)

Controls the input volume level of the Lead channel.

CHANNEL SELECT SWITCH (10)

Allows selection of the Lead or Normal channel.

NOTE: Channel selection may also be achieved by the remote footswitch. If remote selection is desired, the channel switch must be in the "in" (Lead) position.

NORMAL GAIN (11)

Controls the volume level of the Normal channel.

INPUT (12)

The input jack will accept signals from all types of guitar pickups. Be sure to use a high-quality shielded cable to connect the guitar to the amplifier.

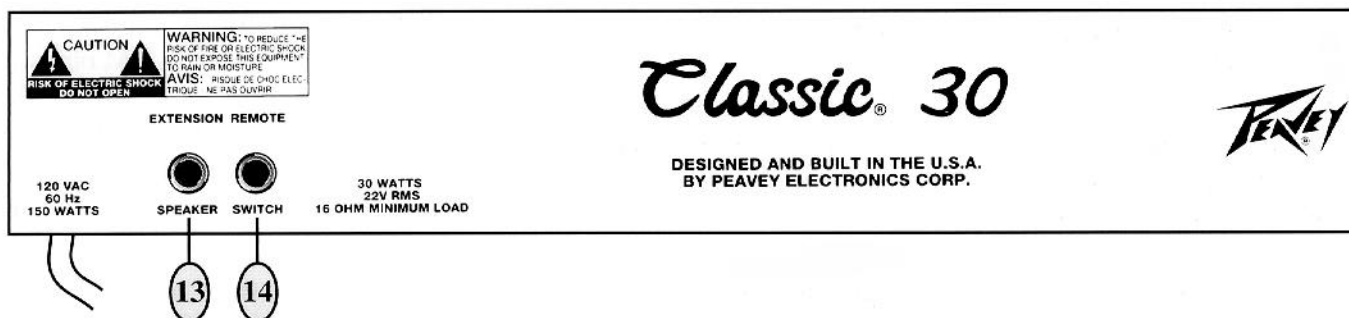

EXTERNAL SPEAKER JACK (13)

Provided for connection of external speaker cabinet. Minimum total impedance is 16 ohms.

REMOTE SWITCH JACK (14)

Provided for the connection of the optional remote footswitch. Footswitch is used to select the Lead or Normal channels and defeat reverb. When using remote footswitch, always insert the plug fully (second click) to ensure proper operation.

SPECIFICATIONS

POWER AMPLIFIER SECTION

4 - 6BQ5/EL84's with 12AX7 driver

Rated Power & Load:

30 W RMS into 16 or 8 ohms

Power @ Clipping: (Typically)

(5% THD, 1 kHz, 120 V AC line)

30 W RMS into 16 or 8 ohms
(Bias must be reduced to measure.)

Frequency Response:

+0, -2 dB, 50 Hz to 15 kHz, @
20 W RMS into 16 ohms

Hum & Noise:

Greater than 80 dB below rated power

Power Consumption:

150 watts, 50/60 Hz,
120 V AC (Domestic)

PREAMP SECTION

2 - 12AX7's

The following specs are measured @ 1 kHz with the controls preset as follows:

Pre & Post (lead) @ 0
Reverb Level @ 0
Bass & Treble EQ @ 12
Middle EQ @ 0
Channel Select Out
Boost Switch Out

Nominal level is with Input Gain @ 6.

Minimum level is with input Gain @ 12.

Preamp Normal Input:

Impedance: Very high Z,
470 kilohms

Lead Channel

(Post gain @ 12)

Nominal Input Level
-40 dBV, 10 mV RMS
Minimum Input Level:
-70 dBV, 0.3 mV RMS

Normal Channel:

Nominal Input Level:
-17 dBV, 140 mV RMS
Minimum Input Level:
-28 dBV, 40 mV RMS

Maximum Input Level:

0 dBV, 1.0 V RMS

Equalization:

(Lead & Normal Channels)

Custom bass, middle & treble passive-type EQ

Effects Send:

Load Impedance: 1 kilohm or greater

Nominal Output Level:
-6 dBV, 0.5 V RMS

Effects Return:

Impedance: High Z, 2 M ohms
Designed input Level:
-6 dBV, 0.5 V RMS (Switching jack provides Effects Send to Effects Return connection when not used.)

External Footswitch Function:

Reverb Defeat
(when reverb control is raised)
Normal/Lead Channel Select
(when Lead activated)

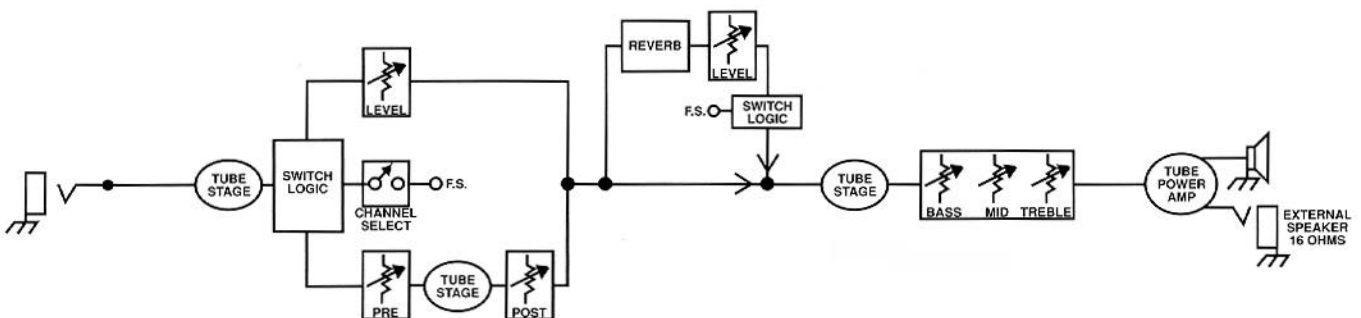

STONE ISLAND

TONE SETTINGS

ROCK

Diagram showing the Rock tone settings for the Stone Island amplifier. The settings are as follows:

- POWER:** ON
- PILOT:** OFF
- EFX. SEND:** ON
- EFX. RET.:** ON
- TREBLE:** 7
- MIDDLE:** 7
- BASS:** 7
- REVERB:** 0
- POST:** 7
- PRE:** 7
- CHANNEL:** NORMAL
- BOOST:** "OUT"
- INPUT:** "IN"

METAL

Diagram showing the Metal tone settings for the Stone Island amplifier. The settings are as follows:

- POWER:** ON
- PILOT:** OFF
- EFX. SEND:** ON
- EFX. RET.:** ON
- TREBLE:** 10
- MIDDLE:** 7
- BASS:** 7
- REVERB:** 0
- POST:** 7
- PRE:** 7
- CHANNEL:** NORMAL
- BOOST:** "OUT"
- INPUT:** "IN"

BLUES

Diagram showing the Blues tone settings for the Stone Island amplifier. The settings are as follows:

- POWER:** ON
- PILOT:** OFF
- EFX. SEND:** ON
- EFX. RET.:** ON
- TREBLE:** 7
- MIDDLE:** 7
- BASS:** 7
- REVERB:** 0
- POST:** 7
- PRE:** 7
- CHANNEL:** NORMAL
- BOOST:** "OUT"
- INPUT:** "OUT"
- Channel Note:** IN FOR LEAD

COUNTRY

Diagram showing the Country tone settings for the Stone Island amplifier. The settings are as follows:

- POWER:** ON
- PILOT:** OFF
- EFX. SEND:** ON
- EFX. RET.:** ON
- TREBLE:** 7
- MIDDLE:** 7
- BASS:** 7
- REVERB:** 0
- POST:** 7
- PRE:** 7
- CHANNEL:** NORMAL
- BOOST:** "OUT"
- INPUT:** "OUT"
- Channel Note:** IN FOR LEAD

ESPAÑOL

Consulte los diagramas del panel delantero en la sección de ingles de este manual.

POWER SWITCH (Interruptor de corriente) (1)

Coloque a la posición "on" para encender.

PILOT LIGHT LED (LED indicadora de lampara piloto) (2)

Se ilumina cuando el amplificador recibe corriente alterna.

EFFECTS RETURN (Retorno de efectos) (3)

Entrada para el retorno de señales procedentes de equipos de efectos externos o de equipos procesadores de señal.

EFFECTS SEND (Envío de efectos) (4)

Salida para enviar señales a efectos externos o equipos procesadores de señal.

TREBLE, MIDDLE, AND BASS EQ (Ecuador de tiples, medias, y agudas) (5)

Controles de tono pasivo que regulan las frecuencias altas, medias y agudas, respectivamente.

BOOST SWITCH (6)

Proporciona impulso a la ganancia general del sistema. Para activado oprímalo a la posición "in" (hacia adentro).

REVERB (Control de reverberación) (7)

La reverberación es un efecto de eco. Haga girar a la derecha para aumentar el efecto. El encendido/apagado ("on/off") se puede controlar con el pedal interruptor de control remoto.

POST GAIN (Control de ganancia posterior del preamplificador) (8)

Controla el volumen general del canal solista. El ajuste final de nivel debe hacerse después de que se haya obtenido el sonido deseado.

PRE GAIN (Control del preamplificador) (9)

Controla la entrada de volumen del canal solista.

CHANNEL SELECT SWITCH (Interruptor de selección de canal) (10)

Permite la selección del canal "Lead" (solista) o Normal.

NOTA: También se puede lograr la selección del canal por medio del pedal interruptor remoto. Si desea la selección a control remoto, el interruptor de canal debe estar en la posición "in" (hacia adentro) (canal de solista).

NORMAL GAIN (Ganancia normal) (11)

Controla el nivel de volumen del canal Normal.

INPUT (Entrada) (12)

El enchufe hembra de entrada acepta todo tipo de señales provenientes de captadoras de instrumentos eléctricos de cuerda. Asegúrese de usar cables blindados de buena calidad, para conectar su instrumento al amplificador.



EXTERNAL SPEAKER JACK (13)

Se suministra para la conexión de bafles externos. La impedancia total mínima es de 16 ohms.

REMOTE SWITCH JACK (Enchufe hembra de interruptor remoto) (14)

Se suministra para la conexión del pedal interruptor de control remoto opcional. El pedal interruptor se utiliza para seleccionar los canales solista o normal y desactivar la reverberación. Cuando utilice el pedal de control remoto, inserte siempre la clavija completamente (segundo retén) para asegurar el correcto funcionamiento.

FRANCAIS

Veillez vous référer au "front panel line art" situé dans la section en langue anglaise de ce manuel.

POWER SWITCH (Interrupteur d'alimentation) (1)

Mettre en position "On" pour mettre sous tension.

PILOT LIGHT LED (DEL témoin) (2)

S'allume lorsque l'ampli reçoit l'alimentation CA.

EFFECTS RETURN (Retour d'effets) (3)

Prise d'entrée pour signaux provenant d'appareils externes de traitement de signal ou d'effets.

EFFECTS SEND (Envoi d'effets) (4)

Prise de sortie servant à fournir des signaux à des appareils externes de traitement de signal ou d'effets.

TREBLE, MIDDLE, AND BASS EQ (Égalisation aiguës, moyennes, graves) (5)

Réglages de tonalité passif ajustant respectivement les fréquences aiguës, moyennes et graves.

BOOST SWITCH (6)

Hausse le gain global du système. Abaisser à la position "In" pour activer.

REVERB (Réverbération) (7)

La réverbération es un effet d'écho. Tournez dans le sens du mouvement des aiguilles d'une montre pour augmenter l'intensité de l'effet. L'interrupteur au pied peut contrôler la mise en circuit ou hors circuit ("On/Off").

POST GAIN (8)

Commande le volume général du canal "Lead". Le réglage final de niveau doit être effectué après avoir obtenu la sonorité désirée à l'aide des autres réglages.

PRE GAIN (9)

Contrôle le niveau de volume à l'entrée du canal "Lead".

CHANNEL SELECT SWITCH (Sélecteur de canal) (10)

Permet de sélectionner les canaux "Lead" ou "Normal".

NOTE: La sélection de canal peut aussi s'accomplir à distance à l'aide de la pédale-interrupteur. Pour que la sélection à distance soit possible, le canal doit être en position "In" ("Lead").

NORMAL GAIN (Gain canal Normal) (11)

Contrôle le niveau de volume du canal "Normal".

INPUT (Entrée) (12)

Cette prise d'entrée accepte les signaux de tous les types de micros ("pickups") de guitare. Utilisez toujours un câble blindé de haute qualité pour relier la guitare à l'amplificateur.

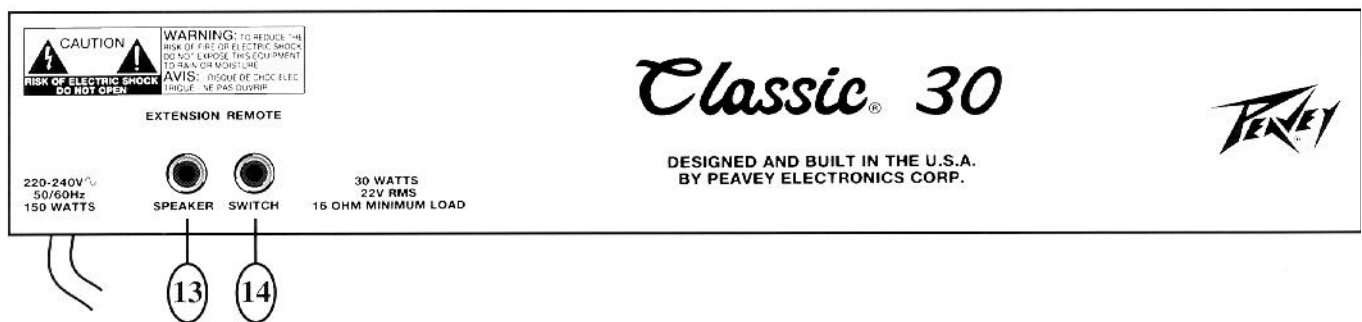

EXTERNAL SPEAKER JACK (13)

Sortie pour branchement d'une enceinte de haut-parleur séparée. L'impédance totale résultante doit être au minimum 16 ohms.

REMOTE SWITCH JACK (Prise pour interrupteur à distance) (14)

Sert à brancher la pédale-interrupteur (en option). L'interrupteur au pied est utilisé pour sélectionner les canaux "Lead" ou "Normal" et mettre la réverbération hors service. Afin d'assurer un bon fonctionnement lors de l'utilisation de l'interrupteur au pied, insérez la fiche à fond jusqu'au second cran (au second clic).

DEUTSCH

Siehe Diagramm der Frontplatte im englischen Teil des Handbuchs.

POWER SWITCH (1)

Zum Einschalten diesen Schalter auf "on" stellen.

PILOT LIGHT (2)

Leuchtet auf, wenn das Gerät eingeschaltet ist.

EFFECTS RETURN (3)

Eingang für die von externen Effektgeräten zurückerkommenden Signale.

EFFECTS SEND (4)

Ausgang für externe Effekte.

TREBLE, MIDDLE, AND BASS EQ (5)

Passive Klangregler die jeweils die Höhen, Mitten und Bässe bearbeiten.

BOOST SWITCH (6)

Boostet die Gesamtlautstärke. Zum Einschalten auf die "In"- Position bringen.

REVERB (7)

Eingebautes Echo-Hall-System. In Uhrzeigerrichtung drehen, um den Effekt zu verstärken. Fernbedienungs Fußschalter zum Ein- und Ausschalten des Effekts.

POST GAIN (8)

Kontrolliert den gesamten Lautstärke-pegel des Hauptkanals (Mastervolumen). Die endgültige Lautstärkeregelung sollte vorgenommen werden, nachdem der gewünschte Sound eingestellt ist.

PRE GAIN (9)

Kontrolliert den Vorstufenpegel des Lead-Kanals.

CHANNEL SELECT SWITCH (10)

Zur Umschaltung von Lead auf Normal Kanal.

MERKE: Kanalwahl kann auch mittels dem Fernbedienungsfußschalter ausgeführt werden. Dazu muß der "Channel"-Schalter sich in der "in" (lead) Position befinden.

NORMAL GAIN (11)

Regelt den Pegel des Normal Kanals.

INPUT (12)

Diese Eingangsbuchse verarbeitet Signale von Gitarrentonabnehmern aller Art. Verwenden Sie bitte nur ein qualitativ hochwertiges abgeschirmtes Kabel zum Anschluß der Gitarre an den Verstärker.

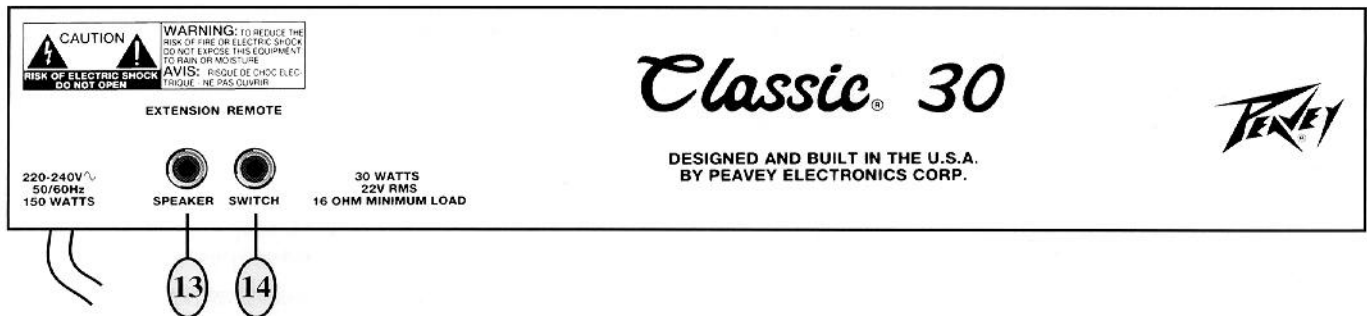

EXTERNAL SPEAKER JACK (13)

Anschlußbuchse für einen zusätzlichen Lautsprecher. Die minimale Gesamtimpedanz beträgt 16 Ohm.

REMOTE SWITCH JACK (14)

Vorgesehen für den Anschluß des als Option erhältlichen Fußschalters. Der Fußschalter kann zum Anwählen des Normal- und Leadkanals sowie zum Schalten des Halls verwendet werden. Um eine einwandfreie Funktion zu gewährleisten, ist beim Anschluß des Fußschalters darauf zu achten, daß der Stecker vollständig (bis zum 2. Klick) eingesteckt ist. ion erhältlichen Fußschalters. Der Fußschalter kann zum Anwählen des Normalund Leadkanals sowie zum Schalten des Halls verwendet werden. Um eine einwandfreie Funktion zu gewährleisten, ist beim Anschluß des Fußschalters darauf zu achten, daß der Stecker vollständig (bis zum 2. Klick)

THIS LIMITED WARRANTY VALID ONLY WHEN PURCHASED AND REGISTERED IN THE UNITED STATES OR CANADA. ALL EXPORTED PRODUCTS ARE SUBJECT TO WARRANTY AND SERVICES TO BE SPECIFIED AND PROVIDED BY THE AUTHORIZED DISTRIBUTOR FOR EACH COUNTRY.

Ces clauses de garantie ne sont valables qu'aux Etats-Unis et au Canada. Dans tous les autres pays, les clauses de garantie et de maintenance sont fixées par le distributeur national et assurées par lui selon la législation en vigueur.

Diese Garantie ist nur in den USA und Kanada gültig. Alle Export-Produkte sind der Garantie und dem Service des Importeurs des jeweiligen Landes unterworfen. Esta garantía es válida solamente cuando el producto es comprado en E.U. continentales o en Canada. Todos los productos que sean comprados en el extranjero, están sujetos a las garantías y servicio que cada distribuidor autorizado determine y ofrezca en los diferentes países.

PEAVEY ONE-YEAR LIMITED WARRANTY/REMEDY

PEAVEY ELECTRONICS CORPORATION ("PEAVEY") warrants this product, EXCEPT for covers, footswitches, patchcords, tubes and meters, to be free from defects in material and workmanship for a period of one (1) year from date of purchase, PROVIDED, however, that this limited warranty is extended only to the original retail purchaser and is subject to the conditions, exclusions, and limitations hereinafter set forth:

PEAVEY 90-DAY LIMITED WARRANTY ON TUBES AND METERS

If this product contains tubes or meters, Peavey warrants the tubes or meters contained in the product to be free from defects in material and workmanship for a period of ninety (90) days from date of purchase; PROVIDED, however, that this limited warranty is extended only to the original retail purchaser and is also subject to the conditions, exclusions, and limitations hereinafter set forth.

CONDITIONS, EXCLUSIONS, AND LIMITATIONS OF LIMITED WARRANTIES

These limited warranties shall be void and of no effect, if:

- a. The first purchase of the product is for the purpose of resale; or
- b. The original retail purchase is not made from an AUTHORIZED PEAVEY DEALER; or
- c. The product has been damaged by accident or unreasonable use, neglect, improper service or maintenance, or other causes not arising out of defects in material or workmanship; or
- d. The serial number affixed to the product is altered, defaced, or removed.

In the event of a defect in material and/or workmanship covered by this limited warranty, Peavey will:

- a. In the case of tubes or meters, replace the defective component without charge.
- b. In other covered cases (i.e., cases involving anything other than covers, footswitches, patchcords, tubes or meters), repair the defect in material or workmanship or replace the product, at Peavey's option; and provided, however, that, in any case, all costs of shipping, if necessary, are paid by you, the purchaser.

THE WARRANTY REGISTRATION CARD SHOULD BE ACCURATELY COMPLETED AND MAILED TO AND RECEIVED BY PEAVEY WITHIN FOURTEEN (14) DAYS FROM THE DATE OF YOUR PURCHASE.

In order to obtain service under these warranties, you must:

- a. Bring the defective item to any PEAVEY AUTHORIZED DEALER or AUTHORIZED PEAVEY SERVICE CENTER and present therewith the ORIGINAL PROOF OF PURCHASE supplied to you by the AUTHORIZED PEAVEY DEALER in connection with your purchase from him of this product. If the DEALER or SERVICE CENTER is unable to provide the necessary warranty service you will be directed to the nearest other PEAVEY AUTHORIZED DEALER or AUTHORIZED PEAVEY SERVICE CENTER which can provide such service.

OR

- b. Ship the defective item, prepaid, to:

PEAVEY ELECTRONICS CORPORATION
International Service Center
326 Hwy. 11 & 80 East
MERIDIAN, MS 39301

including therewith a complete, detailed description of the problem, together with a legible copy of the original PROOF OF PURCHASE and a complete return address. Upon Peavey's receipt of these items:

If the defect is remedial under these limited warranties and the other terms and conditions expressed herein have been complied with, Peavey will provide the necessary warranty service to repair or replace the product and will return it, FREIGHT COLLECT, to you, the purchaser.

Peavey's liability to the purchaser for damages from any cause whatsoever and regardless of the form of action, including negligence, is limited to the actual damages up to the greater of \$500.00 or an amount equal to the purchase price of the product that caused the damage or that is the subject of or is directly related to the cause of action. Such purchase price will be that in effect for the specific product when the cause of action arose. This limitation of liability will not apply to claims for personal injury or damage to real property or tangible personal property allegedly caused by Peavey's negligence. Peavey does not assume liability for personal injury or property damage arising out of or caused by a non-Peavey alteration or attachment, nor does Peavey assume any responsibility for damage to interconnected non-Peavey equipment that may result from the normal functioning and maintenance of the Peavey equipment.

UNDER NO CIRCUMSTANCES WILL PEAVEY BE LIABLE FOR ANY LOST PROFITS, LOST SAVINGS, ANY INCIDENTAL DAMAGES, OR ANY CONSEQUENTIAL DAMAGES ARISING OUT OF THE USE OR INABILITY TO USE THE PRODUCT, EVEN IF PEAVEY HAS BEEN ADVISED OF THE POSSIBILITY OF SUCH DAMAGES.

THESE LIMITED WARRANTIES ARE IN LIEU OF ANY AND ALL WARRANTIES, EXPRESSED OR IMPLIED, INCLUDING, BUT NOT LIMITED TO, THE IMPLIED WARRANTIES OF MERCHANTABILITY AND FITNESS FOR A PARTICULAR USE; PROVIDED, HOWEVER, THAT IF THE OTHER TERMS AND CONDITIONS NECESSARY TO THE EXISTENCE OF THE EXPRESSED, LIMITED WARRANTIES, AS HEREIN ABOVE STATED, HAVE BEEN COMPLIED WITH, IMPLIED WARRANTIES ARE NOT DISCLAIMED DURING THE APPLICABLE ONE-YEAR OR NINETY-DAY PERIOD FROM DATE OF PURCHASE OF THIS PRODUCT.

SOME STATES DO NOT ALLOW LIMITATION ON HOW LONG AN IMPLIED WARRANTY LASTS, OR THE EXCLUSION OR LIMITATION OF INCIDENTAL OR CONSEQUENTIAL DAMAGES, SO THE ABOVE LIMITATIONS OR EXCLUSIONS MAY NOT APPLY TO YOU. THESE LIMITED WARRANTIES GIVE YOU SPECIFIC LEGAL RIGHTS, AND YOU MAY ALSO HAVE OTHER RIGHTS WHICH MAY VARY FROM STATE TO STATE.

THESE LIMITED WARRANTIES ARE THE ONLY EXPRESSED WARRANTIES ON THIS PRODUCT, AND NO OTHER STATEMENT, REPRESENTATION, WARRANTY, OR AGREEMENT BY ANY PERSON SHALL BE VALID OR BINDING UPON PEAVEY.

In the event of any modification or disclaimer of expressed or implied warranties, or any limitation of remedies, contained herein conflicts with applicable law, then such modification, disclaimer or limitation, as the case may be, shall be deemed to be modified to the extent necessary to comply with such law.

Your remedies for breach of these warranties are limited to those remedies provided herein and Peavey Electronics Corporation gives this limited warranty only with respect to equipment purchased in the United States of America.

INSTRUCTIONS — WARRANTY REGISTRATION CARD

1. Mail the completed WARRANTY REGISTRATION CARD to:

PEAVEY ELECTRONICS CORPORATION
POST OFFICE BOX 2898
MERIDIAN, MISSISSIPPI 39302-2898

- a. Keep the PROOF OF PURCHASE. In the event warranty service is required during the warranty period, you will need this document. There will be no identification card issued by Peavey Electronics Corporation.
2. **IMPORTANCE OF WARRANTY REGISTRATION CARDS AND NOTIFICATION OF CHANGES OF ADDRESSES:**
 - a. Completion and mailing of WARRANTY REGISTRATION CARDS — Should notification become necessary for any condition that may require correction, the REGISTRATION CARD will help ensure that you are contacted and properly notified.
 - b. Notice of address changes — If you move from the address shown on the WARRANTY REGISTRATION CARD, you should notify Peavey of the change of address so as to facilitate your receipt of any bulletins or other forms of notification which may become necessary in connection with any condition that may require dissemination of information or correction.
3. You may contact Peavey directly by telephoning (601) 483-5365.

IMPORTANT SAFETY INSTRUCTIONS

WARNING: When using electric products, basic cautions should always be followed, including the following.

1. Read all safety and operating instructions before using this product.
2. All safety and operating instructions should be retained for future reference.
3. Obey all cautions in the operating instructions and on the back of the unit.
4. All operating instructions should be followed.
5. This product should not be used near water, i.e., a bathtub, sink, swimming pool, wet basement, etc.
6. This product should be located so that its position does not interfere with its proper ventilation. It should not be placed flat against a wall or placed in a built-in enclosure that will impede the flow of cooling air.
7. This product should not be placed near a source of heat such as a stove, radiator, or another heat producing amplifier.
8. Connect only to a power supply of the type marked on the unit adjacent to the power supply cord.
9. Never break off the ground pin on the power supply cord. For more information on grounding, write for our free booklet "Shock Hazard and Grounding."
10. Power supply cords should always be handled carefully. Never walk or place equipment on power supply cords. Periodically check cords for cuts or signs of stress, especially at the plug and the point where the cord exits the unit.
11. The power supply cord should be unplugged when the unit is to be unused for long periods of time.
12. If this product is to be mounted in an equipment rack, rear support should be provided.
13. Metal parts can be cleaned with a damp rag. The vinyl covering used on some units can be cleaned with a damp rag or an ammonia-based household cleaner if necessary. Disconnect unit from power supply before cleaning.
14. Care should be taken so that objects do not fall and liquids are not spilled into the unit through the ventilation holes or any other openings.
15. This unit should be checked by a qualified service technician if:
 - a. The power supply cord or plug has been damaged.
 - b. Anything has fallen or been spilled into the unit.
 - c. The unit does not operate correctly.
 - d. The unit has been dropped or the enclosure damaged.
16. The user should not attempt to service this equipment. All service work should be done by a qualified service technician.
17. This product should be used only with a cart or stand that is recommended by Peavey Electronics.
18. Exposure to extremely high noise levels may cause a permanent hearing loss. Individuals vary considerably in susceptibility to noise induced hearing loss, but nearly everyone will lose some hearing if exposed to sufficiently intense noise for a sufficient time. The U.S. Government's Occupational Safety and Health Administration (OSHA) has specified the following permissible noise level exposures.

Duration Per Day In Hours	Sound Level dBA, Slow Response
8	90
6	92
4	95
3	97
2	100
1 1/2	102
1	105
1/2	110
1/4 or less	115

According to OSHA, any exposure in excess of the above permissible limits could result in some hearing loss.

Ear plugs or protectors in the ear canals or over the ears must be worn when operating this amplification system in order to prevent a permanent hearing loss if exposure is in excess of the limits as set forth above. To ensure against potentially dangerous exposure to high sound pressure levels, it is recommended that all persons exposed to equipment capable of producing high sound pressure levels such as this amplification system be protected by hearing protectors while this unit is in operation.

SAVE THESE INSTRUCTIONS!



Features and specifications subject to change without notice.

Peavey Electronics Corporation 711 A Street / Meridian, MS 39302-2898 / U.S.A. / (601)483-5365 / Telex 504115 / Fax 486-1278

©1993

#80301964

Printed in U.S.A. 9/93