

RG-16

User's Manual



RJM Music Technology, Inc.

RG-16

User's Manual

Version 1.2
January 5, 2009

RJM Music Technology, Inc.
2525 Pioneer Ave.
Suite 2
Vista, CA 92081
+1-760-597-9450
email: support@rjmmusic.com
web: www.rjmmusic.com

Copyright © 2008 RJM Music Technology, Inc. All Rights Reserved

RG-16, Amp Gizmo, MasterMind and the RJM logo are trademarks of RJM Music Technology, Inc.

Table of Contents

Table of Contents	v
Introduction	1
RG-16 Features	1
Controls and Connectors	4
Front Panel.....	4
Rear Panel.....	4
Setup Examples	6
MIDI Usage	8
MIDI Continuous Controllers.....	8
Bank Selection	9
Backing Up Your Settings: Sysex Dump	9
Setup Mode	10
Selecting MIDI Channel and MIDI Options.....	10
MIDI Channels.....	10
Continuous Controller Ranges	10
GCX Compatibility Mode	11
CC Disable	11
Bank Select Enable	11
Saving MIDI Channel and Options	11
Invert Mode	11
Momentary Mode	11
Group Mode	12
Quick Setup Buttons.....	12
Troubleshooting	13
Specifications	14
Amp Connector Pinout	14
RG-16 MIDI Implementation Chart	15
Warranty	18

Introduction

Congratulations on purchasing the RG-16 audio loop and function switcher. The RG-16 has been designed to give you total control of your amplifier, effects devices, effects pedals or other electronic equipment from a single MIDI footswitch.

The RG-16 provides eight audio loops, eight function switches and a professional quality audio buffer, all in a compact, single rack space design. Using the RG-16, you can control virtually any amplifier or effects unit – more than with any other MIDI-based switching controller. A wide range of custom cables are available to connect the RG-16 to the vast majority of the amplifiers on the market, and we are continually developing new cables to support additional amplifiers and equipment.

RG-16 Features

- Eight audio loops for effect switching (four grouped in series, four independent)
- Eight function switches for amplifier control (channels, reverb, effects loops, etc.)
- A high-quality audio buffer that can be placed anywhere in the audio path
- Two 8-pin DIN jacks allow you to control up to two amps simultaneously
- Works with all MIDI footswitches
- Responds to Program Change and Continuous Controller messages
- Easy programmability via front panel buttons and LEDs
- Up to 256 programs can be saved in memory
- High-quality relays for optimal sonic performance, compatibility and reliability
- Supports both latching and momentary switching modes
- Electrically isolated jacks prevent ground loops and allow safe control of multiple amplifiers
- Provides phantom power to compatible MIDI devices when used with 7-pin MIDI cable

Front Panel

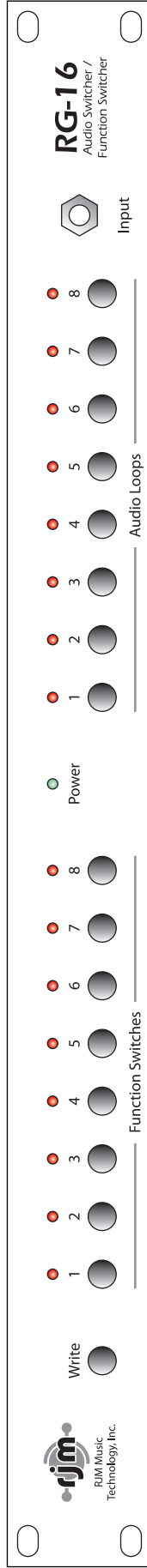

Rear Panel

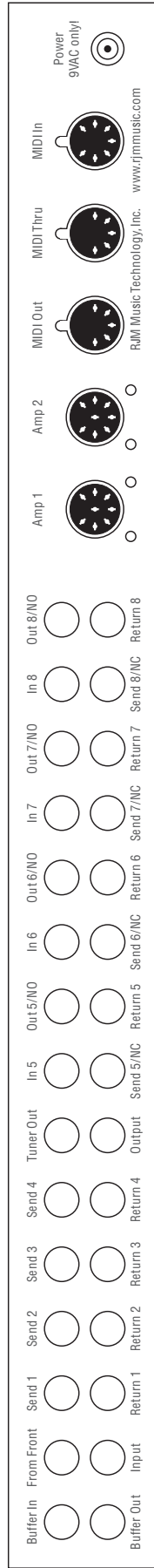

Controls and Connectors

Front Panel

- 1. Write Button** – Hold this button for three seconds to save the current settings to memory. The LEDs will flash to confirm.
- 2. Function Switch Buttons** – These buttons turn function switches 1 through 8 on and off. The LED above each button is lit when the corresponding function switch is on. The Function Switches are used to control channel switching and other features of an amplifier connected to the RG-16 via the Amp 1 and/or Amp 2 jacks.
- 3. Power LED** – Lights when the RG-16 is powered on.
- 4. Audio Loop Buttons** - These buttons turn audio loops 1 through 8 on and off. The LED above each button is lit when the corresponding audio loop is on.
- 5. Input Jack** – This jack is connected to the rear panel From Front jack (8), and will pass a mono or stereo signal through to that connector.

Rear Panel

- 6. Buffer In** – Input to the audio buffer circuit. Using long cables or many effects may degrade the guitar signal, causing it to lose clarity and definition. The audio buffer is used to “strengthen” the guitar signal and preserve sound quality. The effect may vary from subtle to significant, depending on the length and quality of cables and type of effects used in your rig.
- 7. Buffer Out** – Output from the audio buffer circuit.
- 8. From Front** – Signal from the front panel Input Jack (5) appears at this jack.
- 9. Input** – Input to audio loops 1 through 4.

[About Audio Loops 1 through 4](#)

Audio Loops 1 through 4 are connected in series. Each loop is connected internally to the next. When a loop is off, the Send and Receive jacks for that loop are bypassed. The audio signal passes through unchanged. Turning the loop on routes the guitar signal through the send jack and connects the return jack to the next loop.

- 10. Send 1 through 4** – Connect your effects inputs here. When the loop is on, the audio signal will be output at the send jack. When the loop is off, the send jack is grounded and no signal is output.
- 11. Return 1 through 4** – Connect your effects outputs here. When the loop is on, signal sent to these jacks will be passed through to the next loop. If nothing is plugged in to the Return jack, the loop is bypassed and activating the loop will have no effect.
- 12. Tuner Out** – This is an additional output that can be used to connect a tuner. It is connected to the buffer output, so there is only signal present here if the buffer is in use.
- 13. Output** – Output from loops 1 through 4.

[About Audio Loops 5 through 8](#)

Audio loops 5 through 8 are fully independent and not connected to each other in any way. Each loop has its own discrete input and output. When a loop is off, the Send and Receive jacks for that loop are bypassed, and audio signal passes unchanged from loop input to loop output. When a loop is on, the loop input is connected to the Send jack, and the loop output is connected to the Return jack.

14. Input (5 through 8) – Signal input to the corresponding audio loop.

15. Send/NC (5 through 8) – Connect your effects inputs here. When the corresponding loop is on, audio signal will be output at this jack. When the corresponding loop is off, this jack is grounded and no signal is output. (NOTE: This jack can also be used as a Normally Closed function switch.)

16. Output/NO (5 through 8) – Signal output from the corresponding audio loop. (NOTE: this jack can also be used as a Normally Open function switch.)

17. Return (5 through 8) – Connect your effects outputs here. When the corresponding loop is on, audio signal feeding this output will be passed through to the loop output. If nothing is plugged into the Return jack, the loop is bypassed and activating the loop will have no effect.

18. Amp 1 – Connect an amplifier interface cable from this jack to the footswitch jack of your amplifier. This connection enables the RG-16 to control all the footswitch-accessible functions of your amplifier.

19. Amp 2 – Connect a second amplifier interface cable from this jack to the footswitch jack of a second amplifier. This is particularly useful for a stereo rig, where you are using two identical amplifiers, or in an A/B rig, where you have two amps, but are using only one at a time.

Important: Note that Amp 1 and Amp 2 jacks are switched in unison. Any function switching affects both Amp jacks simultaneously. For example, turning Function Switch 1 on will turn that designated function on for both Amp 1 and Amp 2.

20. MIDI Out – MIDI commands and data dumps are sent from this output.

21. MIDI Thru – Any MIDI commands sent to the MIDI In port (22) are output unchanged through this output.

22. MIDI In – Connect your MIDI footswitch (or controller) here to send incoming MIDI commands to the RG-16. NOTE: If your MIDI footswitch supports phantom power, you can connect a 7-pin MIDI cable here and the RG-16 will provide phantom power to the footswitch. Phantom power is supplied by the AC adapter that powers the RG-16. If you use a 9VAC adapter to power the RG-16, the phantom power output will be 9VAC. If you use a 12VDC adapter, the phantom power output will be 12VDC.

23. Power – Connect a 9VAC, 1 Amp (or 12VDC, 1 Amp) power supply here.

Important: Note that the RG-16 uses a 9 Volt AC or 12 Volt DC power supply. Do NOT connect any other power supply to the unit. Many power supplies are very similar in appearance. Connecting the wrong power supply to the RG-16 can damage the unit and void your warranty.

Setup Examples

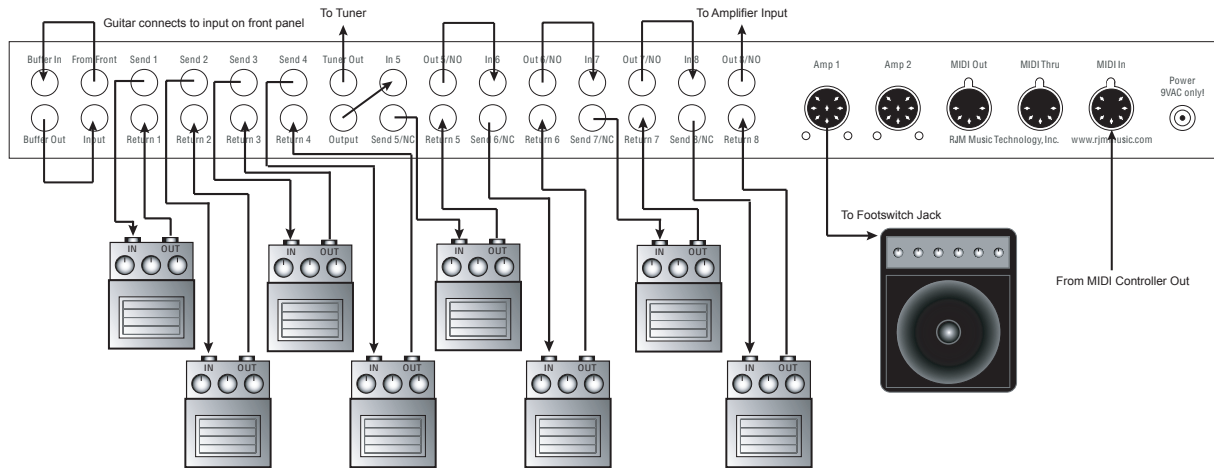

Setup 1 – Four FX Pedals, One Amplifier

This example illustrates a simple configuration for controlling your amp and pedals. Four pedals are connected to Audio Loops 1 through 4, and can be switched on and off using the Audio Loop buttons 1 through 4. The Amp 1 jack is connected to the amplifier's footswitch jack. The Function Switch buttons will control the amp's channel and other features (reverb, solo boost, etc.)

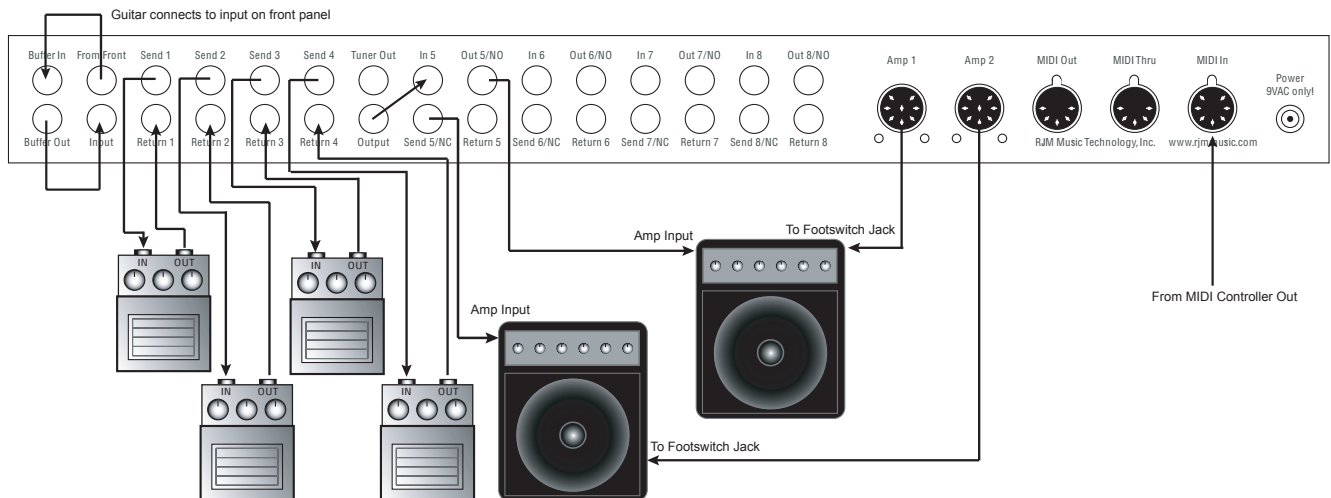

Setup 2 – Four FX Pedals, Two Amps

This is a two amp configuration – you can have either amp on, both amps on, or both amps off. When Audio Loop 5 is on, Amp 1 is active, and when Audio Loop 6 is on, Amp 2 is active. An amp that is not active will have its input muted. Both amplifier switching jacks are used. The amps can be switched simultaneously or independently, depending on the amplifiers and amplifier interface cables being used. In a configuration like this, an isolation transformer may be needed to eliminate noise caused by ground loops.

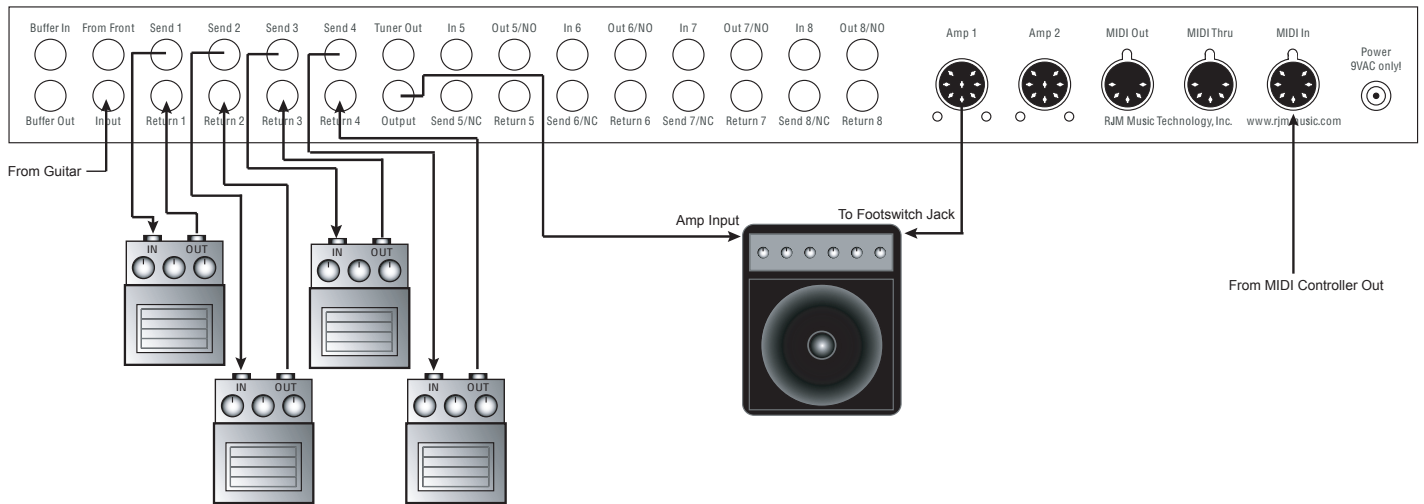

Setup 3 – Eight FX Pedals, Tuner, One Amplifier

In this configuration, all of the audio loops are connected in series to switch 8 different pedals. The audio buffer is connected before the pedals, and the “From Front” jack is used, with the guitar plugged into the RG-16’s front panel input.

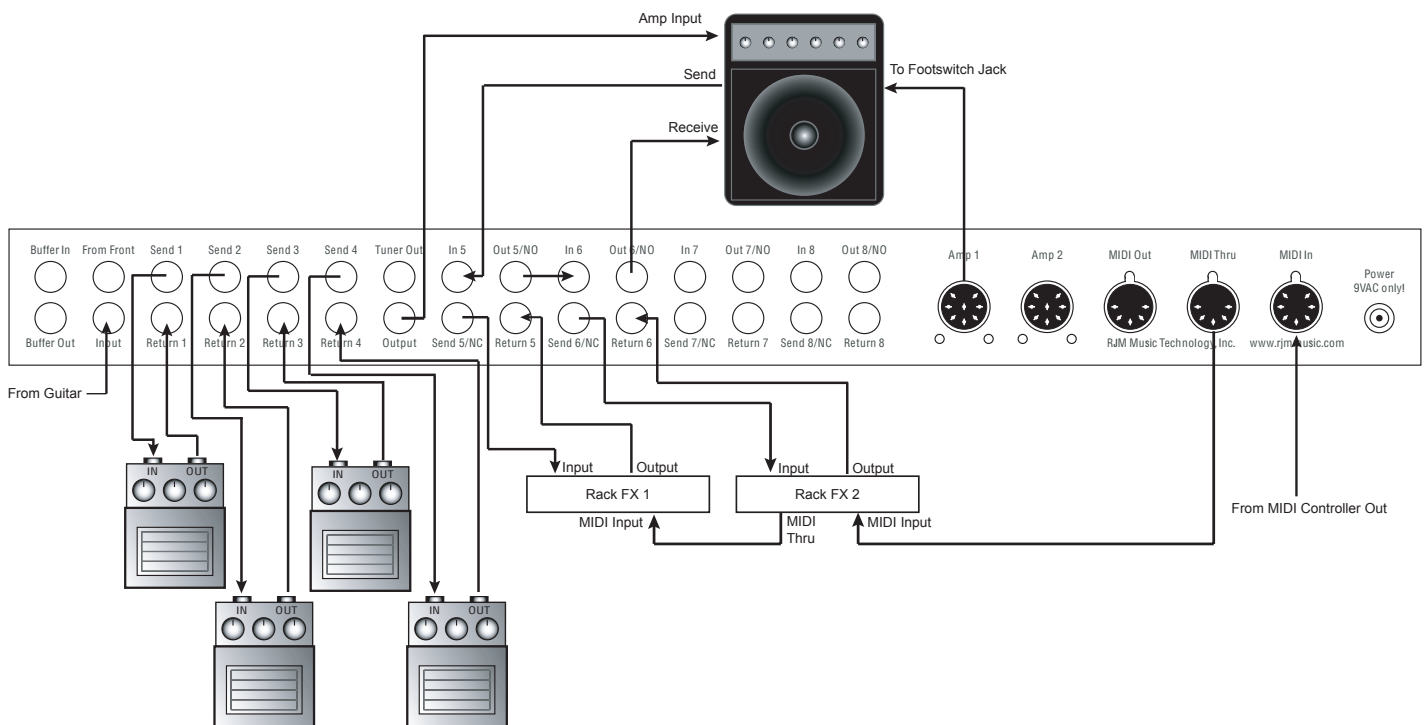

Setup 4 – Four FX Pedals, 2 FX Units in Amp’s Loop

This example shows how you can use the RG-16 in a system where there are effects connected to the amp’s input and effects in the amp’s effects loop. The output of the first four loops is connected to the amp’s input, and loops 5 and 6 are connected to the amp’s effects loop. The RG-16’s MIDI Thru is used to pass MIDI commands to the rack effect units, allowing one MIDI controller to control the entire rig.

MIDI Usage

The RG-16 can receive MIDI messages from any MIDI footswitch or other MIDI controller. By storing different settings, or “patches” for different MIDI program numbers, you can automatically recall a stored patch by sending the correct MIDI program number from your footswitch. You can assign which audio loops and function switches are on for each and every patch.

To save a setting to a MIDI program number:

- Select a MIDI program number with your MIDI footswitch or controller.
- Manually select the desired state of each Function Switch and/or Audio Loop using the RG-16’s front panel buttons.
- Hold down the Write Button (1) until the LEDs flash.

You can save up to 256 patches, using MIDI program numbers 1 through 128 in MIDI banks 0 and 1.

MIDI Continuous Controllers

In addition to supporting MIDI Program Change messages, the RG-16 also supports MIDI Continuous Controller (CC) messages. Using a MIDI controller capable of sending CC messages, you can assign a button on the controller to control a single loop or function switch. For example, you can have a button on your controller assigned to turn an overdrive pedal on or off without affecting any of the other loops or function switches.

By default, the following continuous controller numbers are used:

Audio Loop	CC number	Function Switch	CC number
Loop 1	80	Function 1	88
Loop 2	81	Function 2	89
Loop 3	82	Function 3	90
Loop 4	83	Function 4	91
Loop 5	84	Function 5	92
Loop 6	85	Function 6	93
Loop 7	86	Function 7	94
Loop 8	87	Function 8	95

The continuous controller ranges can be adjusted in Setup Mode.

It is also possible to control the Audio Loops in pairs to allow switching of stereo effects. The CC numbers for stereo operation are as follows:

Audio Loops	CC number
Loops 1 and 2	52
Loops 3 and 4	53
Loops 5 and 6	54
Loops 7 and 8	55

Each Continuous Controller message has a value assigned to it. Values in the range of 0...63 will turn a loop or switch off, and values of 64...127 will turn it on.

Please note that Continuous Controller messages operate exactly the same as pressing buttons on the front panel. All Setup Mode options such as invert and momentary modes will be in effect when processing CC messages, and group mode will be active for single (but not stereo) loop switching.

Bank Selection

The RG-16 can store programs in MIDI banks 0 and 1, for a total of 256 programs. Continuous Controller #0 (Bank MSB) is used to select the current MIDI bank. Bank numbers above bank 1 are ignored.

By default, bank selection is disabled. You can enable bank selection using Setup Mode (see Setup Mode section).

Backing Up Your Settings: Sysex Dump

A Sysex (System Exclusive) data dump will send the current RG-16 system configuration out through the MIDI Out port. You can then save this data to your computer, or copy the settings directly to another RG-16.

Hold down the Audio Loop 5 button while powering up the RG-16, and the RG-16 will immediately send the Sysex Dump. It only takes a couple of seconds to complete.

If you wish to copy settings from one RG-16 to another, connect the MIDI Output of the transmitting unit to the MIDI Input of the receiving unit, then power up the transmitting unit while holding down the Audio Loop 5 button. (Note that the receiving RG-16 must be in normal operating mode to receive data.) The receiving unit will display a progress bar graph on the Audio Loop LEDs. The transfer goes very quickly, taking only a couple of seconds. In the case of an error, the receiving unit will flash all LEDs 5 times.

Once the transfer completes, the receiving unit will reset, then return to normal operating mode. The receiving unit now has an exact copy of the transmitting unit's settings.

Setup Mode

To configure the RG-16, you must first enter Setup Mode. Holding down selected buttons while powering the unit on will bring up selected setup modes, as detailed in this section.

Selecting MIDI Channel and MIDI Options

Hold the Audio Loop 1 button while powering the RG-16 on. Keep holding the button until the LEDs flash. The Audio Loop buttons will then allow you to select the MIDI channel the RG-16 responds to as well as set other MIDI related options.

MIDI Channels

The RG-16 is set by default to send and receive on MIDI Channel 1. To change the send/receive channel, use the Audio Loop buttons to select the channel as shown below:

MIDI Channel	Audio Loop 1 LED	Audio Loop 2 LED	Audio Loop 3 LED	Audio Loop 4 LED
1	OFF	OFF	OFF	OFF
2	ON	OFF	OFF	OFF
3	OFF	ON	OFF	OFF
4	ON	ON	OFF	OFF
5	OFF	OFF	ON	OFF
6	ON	OFF	ON	OFF
7	OFF	ON	ON	OFF
8	ON	ON	ON	OFF
9	OFF	OFF	OFF	ON
10	ON	OFF	OFF	ON
11	OFF	ON	OFF	ON
12	ON	ON	OFF	ON
13	OFF	OFF	ON	ON
14	ON	OFF	ON	ON
15	OFF	ON	ON	ON
16	ON	ON	ON	ON

You can also set a few other MIDI-related options using the Function Switch buttons:

Continuous Controller Ranges

The Function Switch 1 and 2 buttons control the Continuous Controller range for all Audio Loops:

Audio Loop CC Range	GCX Number	Function Switch 1 LED	Function Switch 2 LED
80...87 (default)	1	OFF	OFF
88...95	2	ON	OFF
64...71	3	OFF	ON
56...63	4	ON	ON

The Function Switch 3 and 4 buttons control the Continuous Controller range for all Function Switches:

Function Switch CC Range	GCX Number	Function Switch 3 LED	Function Switch 4 LED
80...87	1	OFF	OFF
88...95 (default)	2	ON	OFF
64...71	3	OFF	ON
56...63	4	ON	ON

[GCX Compatibility Mode](#)

Function Switch 5 turns on GCX compatibility mode for the Audio Loops. This makes the Audio Loops respond to MIDI commands like the GCX switcher, manufactured by Voodoo Lab. In GCX compatibility mode, the Audio Loops respond only to Continuous Controller messages on MIDI channel 16, regardless of the MIDI channel setting. The GCX number is set by Function Switches 1 and 2 (see above).

Function Switch 6 turns on GCX compatibility mode for the Function Switches. The GCX number is set by Function Switches 3 and 4 (see above).

[CC Disable](#)

Function Switch 7 turns on CC Disable mode. This mode prevents the RG-16 from responding to Continuous Controller messages, and is primarily used when debugging a rig. In most circumstances, it's best to keep this option off.

[Bank Select Enable](#)

Function Switch 8 controls whether or not the RG-16 will allow MIDI bank selection. When Function Switch 8 is off, the RG-16 will ignore MIDI bank select messages. When Function Switch 8 is on, the RG-16 will respond to bank select messages as described on page 9.

[Saving MIDI Channel and Options](#)

Once you've set the MIDI channel and options, press the Write button. The RG-16 is now in normal operational mode.

[Invert Mode](#)

Some amplifiers may have inverted polarity on some functions. This can cause the RG-16 to display a function as off when the function is actually on, and as on when the function is actually off. To correct this, you must first switch the RG-16 to Invert Mode.

Hold down the Audio Loop 2 button while powering up the RG-16. Keep holding the button until the LEDs flash. You are now in Invert Mode.

While in Invert Mode, use the front panel buttons to light the LED of any function that is inverted. Make certain no other LED is lit.

Once you've selected the inverted function's associated button(s), press the Write button. The RG-16 is now in normal operational mode, and the inverted functions should operate correctly.

[Momentary Mode](#)

Some devices require momentary-type switching, rather than the more common latching-type switches. (A momentary switch changes OFF/ON state by closing its contacts for a short time and then re-opening them. In Momentary Mode, the RG-16 switches will close for 100 milliseconds before opening again.) Momentary mode is typically only used for Function Switches or Audio Loops that are being used as function switches.

To enter Momentary Mode, hold down the Audio Loop 3 button while powering up the RG-16. Keep holding the button until the LEDs flash. Use the front panel buttons to light the LED of any function that needs to be momentary. Make certain that no other LED is lit.

Once you've selected the buttons for the momentary functions, press the Write button. The RG-16 is now in normal operational mode and the momentary functions should operate correctly.

Group Mode

The Group feature allows you define a group of buttons where pressing one button of the group turns that button on and turns all other buttons in the group off. This is typically used for function switches that control which channel is selected on an amplifier. This prevents the RG-16 from trying to activate more than one amp channel at a time.

To enter Group mode, hold down the Audio Loop 4 button while powering up the RG-16. Keep holding the button until the LEDs flash.

Use the front panel buttons to light the LED of any function that should be in the group. Make sure that no other LEDs are lit.

Note: The groups for Audio Loops and Function Switches are separate. If you set both Audio Loops and Function Switches to be part of a group, pressing an Audio Loop button will only affect other Audio Loops, and pressing a Function Switch button will only affect other Function Switches.

Once you've selected the functions that need to be grouped, press the Write button. The RG-16 is now in normal operational mode and the grouped buttons will now only allow one button to be selected at a time.

Quick Setup Buttons

Quick Setup buttons are provided to quickly set up the Function Switches for common configurations. Which configuration you use depends on the number of channels your amplifier has, and whether the amplifier uses momentary switching or not.

To use this feature, hold one of the following buttons while powering up the RG-16. Hold the button until the LEDs flash. The RG-16 will configure the Function Switch buttons as follows:

Hold Function Switch 1: No switches momentary or grouped. (Default setting)

Hold Function Switch 2: First two switches grouped, no switches momentary. (Most 2 channel amps)

Hold Function Switch 3: First three switches grouped, no switches momentary. (Most 3 channel amps)

Hold Function Switch 4: First four switches grouped, no switches momentary. (Most 4 channel amps)

Hold Function Switch 5: All switches momentary, none grouped. (Rivera M and S amps)

Hold Function Switch 6: First two switches grouped and momentary.

Hold Function Switch 7: First three switches grouped and momentary. (Bogner Ecstasy, EVH 5150III)

Hold Function Switch 8: First four switches grouped and momentary. (Marshall Mode 4)

Once the button has been held and the LEDs have flashed, release the button and the RG-16 will go directly to normal operating mode.

Troubleshooting

Problem: The LEDs don't flash when you hold down the Write Button.

Solution: The RG-16 did not receive a MIDI Program Change message. First, verify that you have a valid MIDI connection. The MIDI output of your MIDI controller should be connected to the MIDI input of the RG-16 by a MIDI cable that's known to be working correctly. The next most likely cause is that the RG-16 is set to a different MIDI channel than your MIDI controller. Check both devices to insure that they're set to the same channel. On the RG-16, the MIDI channel is set to 1 by default and can be changed in Setup Mode.

Problem: There is excessive hum in the audio signal.

Solution: There are a number of reasons that this might happen, but it's often a grounding issue. The grounds are left floating on the RG-16 where possible, so you may need to tie the RG-16 ground to the audio ground in order to eliminate hum. This can be done by either grounding the RG-16 chassis, or by using the RG-16's buffer. If using the RG-16 in a multiple amplifier setup, you may need to use an isolation transformer on one or more amps to eliminate hum caused by ground loops.

Problem: I'm trying to control my amplifier with the RG-16's function switches, and it's not working or behaving erratically.

Solution: This can happen when using the wrong amplifier interface cable, or if the RG-16 is not configured correctly for your amp. Check the instruction sheet that came with your amplifier interface cable, or check the Setup Mode section for more information on how to configure. You can also check contact us at RJM Music for assistance. We'd be happy to help you out.

More troubleshooting tips can be found in the FAQ section of www.rjmmusic.com.

Specifications

Dimensions	Standard 1U EIA rack enclosure 19 (W) x 1.75 (H) x 7.25 (D) inches 48.3 (W) x 4.5 (H) x 18.5 (D) cm
Weight	4 lbs, 4 oz 1.8 kg
Power	9VAC @ 450mA, 12VDC also acceptable 5.5mm OD, 2.5mm ID x 9.5mm barrel connector
Phantom Power	Provided over pins 6 and 7 of the MIDI In jack Voltage provided is the same as power applied at the RG-16 power jack 9VAC, maximum 500mA current when using provided AC adaptor
Memory	256 programs, arranged in 2 banks of 128 Memory is non-volatile and requires no backup battery

Amp Connector Pinout

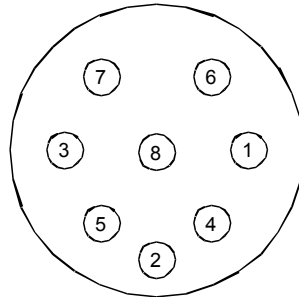

The RG-16 amplifier function switch connectors are female DIN-8 jacks. When a Function Switch is activated on the RG-16, the corresponding pin is shorted to the connector's ground (shield). Activating Function Switch 1 shorts pin 1 (as numbered above) to the connector's ground. Activating Function Switch 2 shorts pin 2, and so on. This happens on both the Amp 1 and Amp 2 jacks. Please note that the amplifier jacks are not electrically connected to each other or to any other part of the RG-16 circuit, so it's safe to connect a different amp to each jack.

RJM Music produces a wide range of cables to allow the RG-16 to control various amplifier models. Please contact your RJM Music dealer or the RJM Music web site to find the correct cable for your amp.

RG-16 MIDI Implementation Chart

MIDI Implementation Chart v 2.0 (Page 1 of 3)			
Manufacturer: RJM Music Technology, Inc. Model: RG-16 Version: 1 Date: January 5, 2009			
	Transmit/Export	Recognize/Import	Remarks
<i>1. Basic Information</i>			
MIDI Channels	1-16	1-16	Channel 1 is set by default
Note Numbers	No	No	
Program change	1-128	1-128	
Bank Select Response? (Yes/No) If yes, list banks utilized in remarks column	No	No	Responds to CC#0 only, Uses banks 0 and 1
Modes supported :			
Mode 1: Omni-On, Poly (Yes/No)	No	No	
Mode 2: Omni-On, Mono (Yes/No)	No	No	
Mode 3: Omni-Off, Poly (Yes/No)	Yes	Yes	
Mode 4: Omni-Off, Mono (Yes/No)	Yes	Yes	
Multi Mode (Yes/No)	No	No	
Note-On Velocity (Yes/No)	No	No	
Note-Off Velocity (Yes/No)	No	No	
Channel Aftertouch (Yes/No)	No	No	
Poly (Key) Aftertouch (Yes/No)	No	No	
Pitch Bend (Yes/No)	No	No	
Active Sensing (Yes/No)	No	No	
System Reset (Yes/No)	No	No	
Tune Request (Yes/No)	No	No	
Universal System Exclusive:	Sample Dump Standard (Yes/No)	No	No
	Device Inquiry (Yes/No)	No	No
	File Dump (Yes/No)	No	No
	MIDI Tuning (Yes/No)	No	No
	Master Volume (Yes/No)	No	No
	Master Balance (Yes/No)	No	No
	Notation Information (Yes/No)	No	No
	Turn GM1 System On (Yes/No)	No	No
	Turn GM2 System On (Yes/No)	No	No
	Turn GM System Off (Yes/No)	No	No
	DLS-1 (Yes/No)	No	No
	File Reference (Yes/No)	No	No
	Controller Destination (Yes/No)	No	No
	Key-based Instrument Ctrl (Yes/No)	No	No
	Master Fine/Coarse Tune (Yes/No)	No	No
Other Universal System Exclusive	No	No	
Manufacturer or Non-Commercial System Exclusive	Yes	Yes	RJM Music Technology, Inc Manuf. ID: 00 01 5B
NRPns (Yes/No)	No	No	
RPN 00 (Pitch Bend Sensitivity) (Yes/No)	No	No	
RPN 01 (Channel Fine Tune) (Yes/No)	No	No	
RPN 02 (Channel Coarse Tune) (Yes/No)	No	No	
RPN 03 (Tuning Program Select) (Yes/No)	No	No	
RPN 04 (Tuning Bank Select) (Yes/No)	No	No	
RPN 05 (Modulation Depth Range) (Yes/No)	No	No	
<i>2. MIDI Timing and Synchronization</i>			
MIDI Clock (Yes/No)	No	No	
Song Position Pointer (Yes/No)	No	No	
Song Select (Yes/No)		No	
Start (Yes/No)	No	No	
Continue (Yes/No)	No	No	
Stop (Yes/No)	No	No	
MIDI Time Code (Yes/No)	No	No	
MIDI Machine Control (Yes/No)	No	No	
MIDI Show Control (Yes/No) If yes, MSC Level supported	No	No	
<i>3. Extensions Compatibility</i>			
General MIDI compatible? (Level(s)/No)	No	No	
Is GM default power-up mode? (Level/No)	No	No	
DLS compatible? (Levels(s)/No) (DLS File Type(s)/No)	No	No	
Standard MIDI Files (Type(s)/No)	No	No	
XMF Files (Type(s)/No)	No	No	
SP-MIDI compatible? (Yes/No)	No	No	

MIDI Implementation Chart v 2.0 (Page 2 of 3)

Manufacturer: RJM Music Technology, Inc. **Model:** RG-16 **Version:** 1 **Date:** January 5, 2009

Control #	Function	Transmitted (Y/N)	Recognized (Y/N)	Remarks
0	Bank Select (MSB)	N	Y	Banks 0 and 1 only
1	Modulation Wheel (MSB)	N	N	
2	Breath Controller (MSB)	N	N	
3		N	N	
4	Foot Controller (MSB)	N	N	
5	Portamento Time (MSB)	N	N	
6	Data Entry (MSB)	N	N	
7	Channel Volume (MSB)	N	N	
8	Balance (MSB)	N	N	
9		N	N	
10	Pan (MSB)	N	N	
11	Expression (MSB)	N	N	
12	Effect Control 1 (MSB)	N	N	
13	Effect Control 2 (MSB)	N	N	
14		N	N	
15		N	N	
16	General Purpose Controller 1 (MSB)	N	N	
17	General Purpose Controller 2 (MSB)	N	N	
18	General Purpose Controller 3 (MSB)	N	N	
19	General Purpose Controller 4 (MSB)	N	N	
20		N	N	
21		N	N	
22		N	N	
23		N	N	
24		N	N	
25		N	N	
26		N	N	
27		N	N	
28		N	N	
29		N	N	
30		N	N	
31		N	N	
32	Bank Select (LSB)	N	N	Use CC#0 instead
33	Modulation Wheel (LSB)	N	N	
34	Breath Controller (LSB)	N	N	
35		N	N	
36	Foot Controller (LSB)	N	N	
37	Portamento Time (LSB)	N	N	
38	Data Entry (LSB)	N	N	
39	Channel Volume (LSB)	N	N	
40	Balance (LSB)	N	N	
41		N	N	
42	Pan (LSB)	N	N	
43	Expression (LSB)	N	N	
44	Effect Control 1 (LSB)	N	N	
45	Effect Control 2 (LSB)	N	N	
46		N	N	
47		N	N	
48	General Purpose Controller 1 (LSB)	N	N	
49	General Purpose Controller 2 (LSB)	N	N	
50	General Purpose Controller 3 (LSB)	N	N	
51	General Purpose Controller 4 (LSB)	N	N	
52		N	Y	Audio Loops 1 and 2
53		N	Y	Audio Loops 3 and 4
54		N	Y	Audio Loops 5 and 6
55		N	Y	Audio Loops 7 and 8
56		N	Y	Alt. CC Range 2
57		N	Y	Alt. CC Range 2
58		N	Y	Alt. CC Range 2
59		N	Y	Alt. CC Range 2
60		N	Y	Alt. CC Range 2
61		N	Y	Alt. CC Range 2
62		N	Y	Alt. CC Range 2
63		N	Y	Alt. CC Range 2

MIDI Implementation Chart v 2.0 (Page 3 of 3)

Manufacturer: RJM Music Technology, Inc. **Model:** RG-16 **Version:** 1 **Date:** January 5, 2009

Control #	Function	Transmitted (Y/N)	Recognized (Y/N)	Remarks
64	Sustain Pedal	N	Y	Alt. CC Range 1
65	Portamento On/Off	N	Y	Alt. CC Range 1
66	Sostenuto	N	Y	Alt. CC Range 1
67	Soft Pedal	N	Y	Alt. CC Range 1
68	Legato Footswitch	N	Y	Alt. CC Range 1
69	Hold 2	N	Y	Alt. CC Range 1
70	Sound Controller 1 (default: Sound Variation)	N	Y	Alt. CC Range 1
71	Sound Controller 2 (default: Timbre / Harmonic Quality)	N	Y	Alt. CC Range 1
72	Sound Controller 3 (default: Release Time)	N	N	
73	Sound Controller 4 (default: Attack Time)	N	N	
74	Sound Controller 5 (default: Brightness)	N	N	
75	Sound Controller 6 (GM2 default: Decay Time)	N	N	
76	Sound Controller 7 (GM2 default: Vibrato Rate)	N	N	
77	Sound Controller 8 (GM2 default: Vibrato Depth)	N	N	
78	Sound Controller 9 (GM2 default: Vibrato Delay)	N	N	
79	Sound Controller 10 (GM2 default: Undefined)	N	N	
80	General Purpose Controller 5	N	Y	Audio Loop 1
81	General Purpose Controller 6	N	Y	Audio Loop 2
82	General Purpose Controller 7	N	Y	Audio Loop 3
83	General Purpose Controller 8	N	Y	Audio Loop 4
84	Portamento Control	N	Y	Audio Loop 5
85		N	Y	Audio Loop 6
86		N	Y	Audio Loop 7
87		N	Y	Audio Loop 8
88		N	Y	Function Switch 1
89		N	Y	Function Switch 2
90		N	Y	Function Switch 3
91	Effects 1 Depth (default: Reverb Send)	N	Y	Function Switch 4
92	Effects 2 Depth (default: Tremolo Depth)	N	Y	Function Switch 5
93	Effects 3 Depth (default: Chorus Send)	N	Y	Function Switch 6
94	Effects 4 Depth (default: Celeste [Detune] Depth)	N	Y	Function Switch 7
95	Effects 5 Depth (default: Phaser Depth)	N	Y	Function Switch 8
96	Data Increment	N	N	
97	Data Decrement	N	N	
98	Non-Registered Parameter Number (LSB)	N	N	
99	Non-Registered Parameter Number(MSB)	N	N	
100	Registered Parameter Number (LSB)	N	N	
101	Registered Parameter Number(MSB)	N	N	
102		N	N	
103		N	N	
104		N	N	
105		N	N	
106		N	N	
107		N	N	
108		N	N	
109		N	N	
110		N	N	
111		N	N	
112		N	N	
113		N	N	
114		N	N	
115		N	N	
116		N	N	
117		N	N	
118		N	N	
119		N	N	
120	All Sound Off	N	N	
121	Reset All Controllers	N	N	
122	Local Control On/Off	N	N	
123	All Notes Off	N	N	
124	Omni Mode Off	N	N	
125	Omni Mode On	N	N	
126	Poly Mode Off	N	N	
127	Poly Mode On	N	N	

Warranty

RJM Music Technology, Inc. warrants this product against any defects in material or workmanship for a period of one year from the original date of purchase.

Should you experience any difficulty with this RJM Music product, please contact us as described below. If it is determined that the product has become defective within the warranty period and must be returned to the factory, RJM Music Technology will issue a Returned Merchandise Authorization (RMA) number and shipping and packaging instructions.

RJM Music Technology will repair or replace the product free of charge, provided it is returned freight prepaid to RJM Music Technology with a copy of a valid receipt and RMA number. Return shipping will be paid by RJM Music Technology within the U.S. only.

This warranty is transferable provided the current owner has the original dated purchase receipt and can provide a copy of it when submitting the warranty claim.

This warranty shall not apply to any goods that have been repaired or altered by anyone other than RJM Music Technology, Inc. or an RJM Music Technology authorized service center. This warranty does not cover damage to the product resulting from accidents or misuse. This is your sole warranty. There are no warranties which extend beyond the terms described herein.

RJM Music Technology, Inc.
2525 Pioneer Ave.
Suite 2
Vista, CA 92081
+1-760-597-9450
E-Mail: support@rjmmusic.com

