

DENON

Hi-Fi Component

SERVICE MANUAL MODEL DCD-485/685

STEREO CD PLAYER

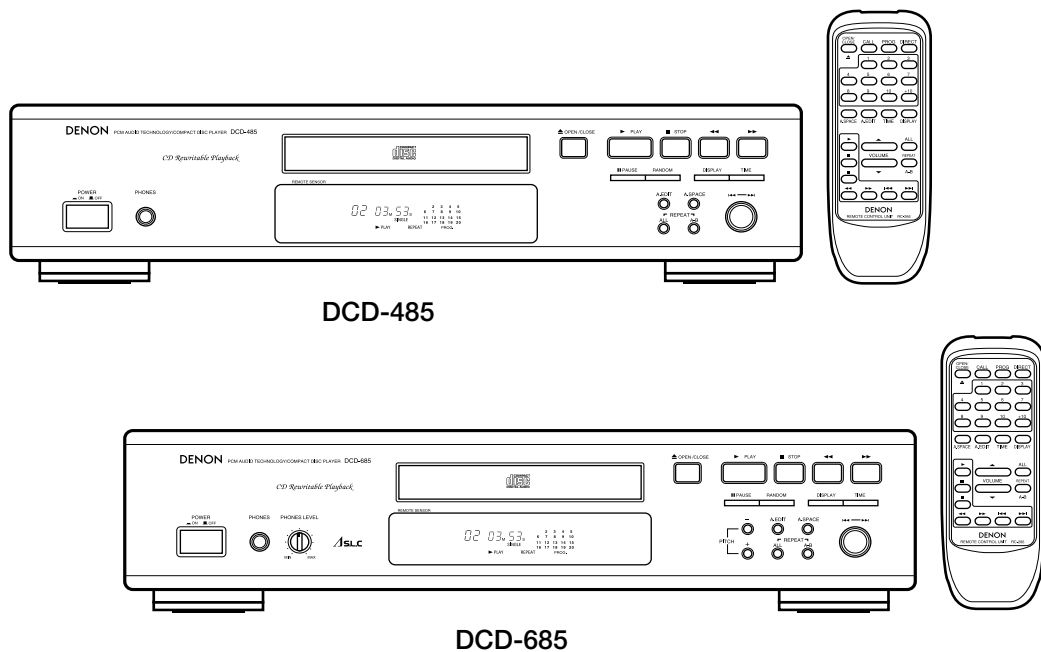

DCD-485

DCD-685

● Some illustration using in this service manual is slightly from the actual set.

NIPPON COLUMBIA CO., LTD.

SAFETY PRECAUTIONS

SAFETY PRECAUTIONS

The following check should be performed for the continued protection of the customer and service technician.

LEAKAGE CURRENT CHECK

Before returning the unit to the customer, make sure you make either (1) a leakage current check or (2) a line to chassis resistance check. If the leakage current exceeds 0.5 milliamps, or if the resistance from chassis to either side of the power cord is less than 460 kohms, the unit is defective.

SPECIFICATIONS

SPECIFICATIONS

	DCD-485	DCD-685
<ul style="list-style-type: none"> ■ AUDIO 		
Number of Channels:	2 channels	←
Frequency Response:	2 to 20 kHz	←
Dynamic Range:	98 dB	100 dB
Signal to Noise ratio:	105 dB	110 dB
Harmonic distortion:	0.003 % (1 kHz)	←
Separation:	102 dB (1 kHz)	103 dB (1 kHz)
Wow and Flutter:	Below measurable limit: (± 0.001 % W. peak)	←
Output Voltage:	0.2 to 2.0 V	←
■ DISCS	Compact Disc format	←
■ GENERAL CHARACTERISTICS		
Power Supply:	AC 230 V, 50 Hz	←
Power consumption:	11 W	12 W
Dimensions:	434 (W) x 100 (H) x 285 (D) mm	←
Mass:	3.4 kg	3.6 kg
■ FUNCTIONS AND DISPLAY		
Functions:	Automatic search, programmed playback, repeat playback, manual search, auto space, time mode, auto edit, dimmer, random playback, pitch control (DCD-685 only)	
Display:	Track number, time, music calendar and engaged modes	
Others:	Headphones jack	
■ REMOTE CONTROL UNIT		
Remote Control System:	RC-266	
Remote Control System:	Infrared pulse system	
Power Supply:	3V DC; two R6P (standard size AA) dry cell batteries	
External Dimensions:	54.5 (W) x 140 (H) x 24.8 (D) mm	
Mass:	85 g including batteries	

* Specifications and design are subject to change without notice for purpose of improvement.

DISASSEMBLY

(Follow the procedure below in reverse order when reassembling)

1. Top Cover

1. Remove 4 screws ① on both sides.
2. Remove 2 screws ② on the Rear Panel.
3. Detach the Top Cover as shown in the fig.

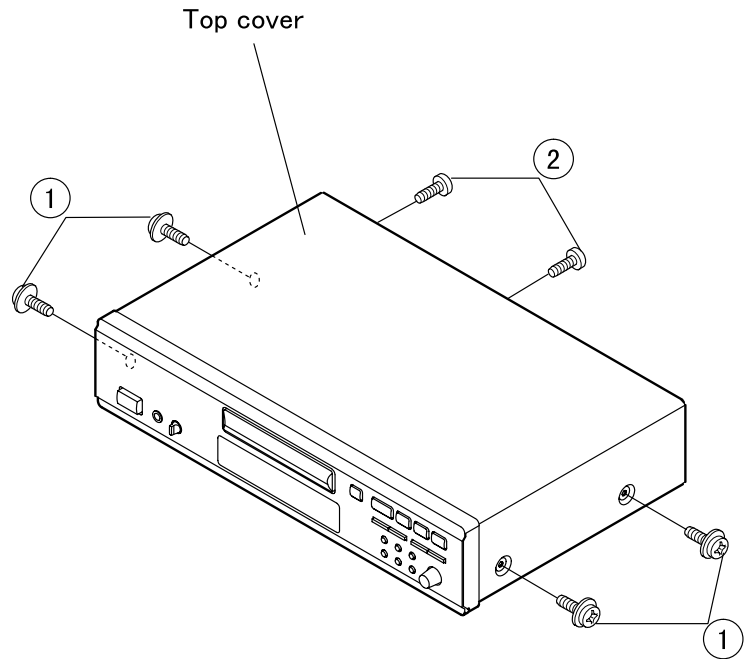

2. Front Panel

1. Remove 1 screw ③ on the Rear Panel and 1 screw ④ fixing Support Bracket (b).
(only DCD-485)
2. Take off the Mecha Cover after removing 2 screws ⑤ .
Open the Tray by turning the Gear (a) clockwise, then detach the Loader Panel.
3. Remove 3 screws ⑥ on the bottom edge of the Front Panel.
4. Remove 2 screws ⑦ , at L/R ends of the Front Panel and 1 screw ⑧ fixing Phone P.W.B.

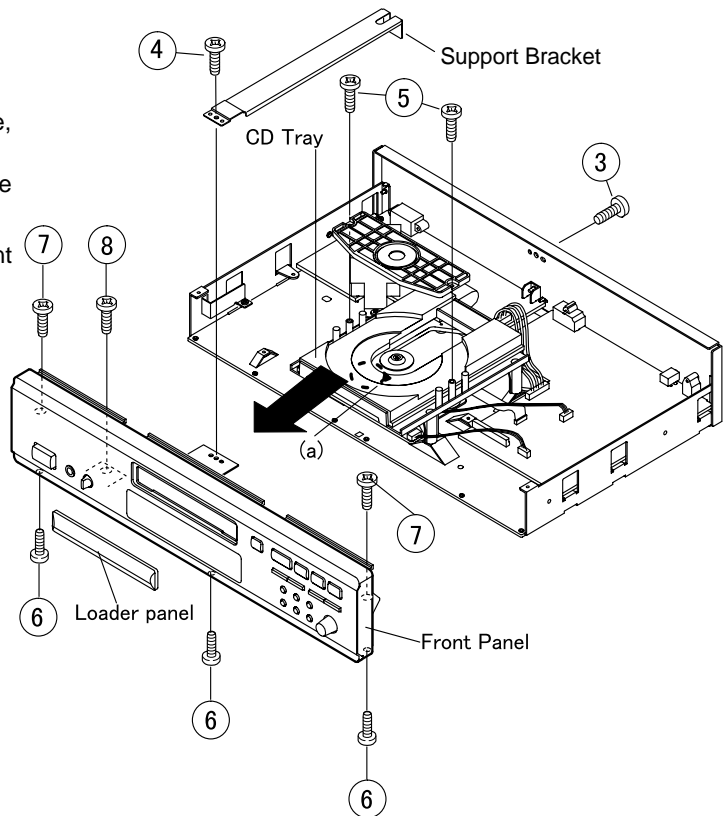

3. CD Mecha. Unit

1. Remove 4 screws ⑨ fixing the CD Mecha.
2. Unplug Connectors (b), (c) and FFC from each socket.
3. Release the FFC from the Clamper.

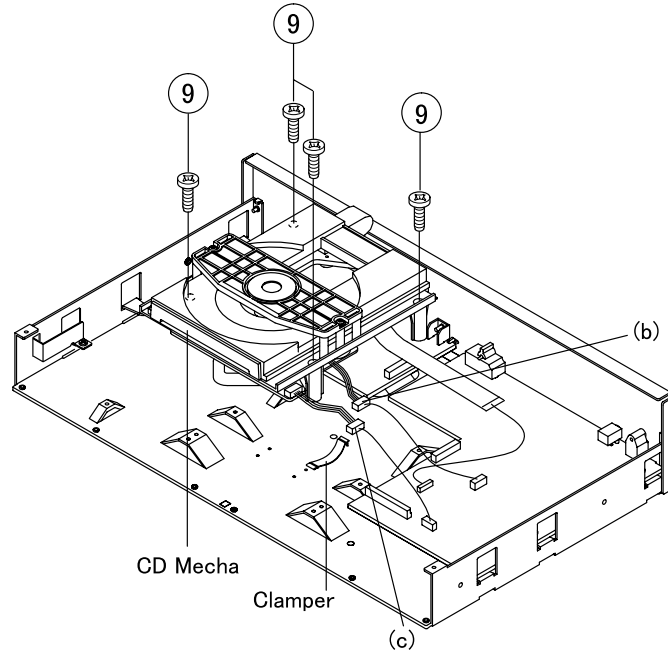

4. Main P.W.B.

1. Remove 5 screws ⑩, 5 screws ⑪ on the Rear Panel and detach it.
2. Remove 3 screws ⑫ fixing the Main P.W.B.
3. Unfasten 1 P.W.B. Holder to detach the Main P.W.B.
4. Remove 1 screw ⑬ and 2 screw ⑭ fixing the Power P.W.B.
5. Unfasten 1 P.W.B. Holder to detach the Power P.W.B.

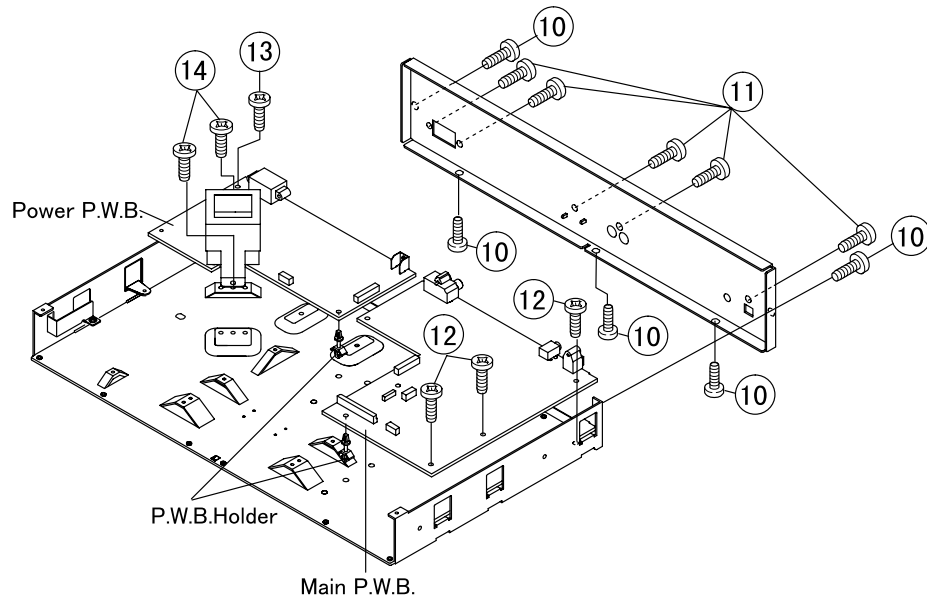

CD TEST MODE

- Setting of the test mode

How to start the test mode: Turn on the power in the condition that CLOSE (Pin No.③) and OPEN (Pin No.④) of CX053 are being shorted. (“01” is indicated on the DISPLAY)

To exit from the test mode, turn off the power. (Refer to Fig. 1 “Test Point Layout”)

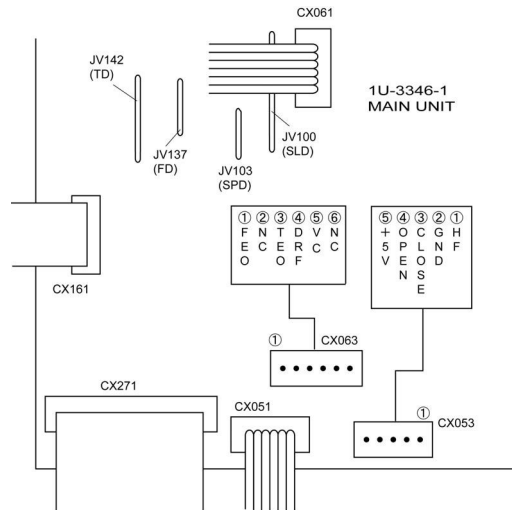

Fig. 1 “Test Point” Layout

- * Laser light of the pickup is always emitted regardless of DISC loading in the test mode.
You may lose your eyesight if you look into the laser directly.
So be careful enough when operating in the test mode.

- Used DISC: A-BEX TCD784

- Explanation of each button

- * Use only the buttons described below for operations while in the test mode, and don't push any other buttons.

Names of buttons	Operation
OPEN / CLOSE	* Loads or unloads DISC
PLAY	* Emits laser light * Repeats search operation (No DISC condition: While it's pressed) * Actuates focus servo (In case of DISC loaded) * Actuates tracking servo
STOP	* Stops operation
PAUSE	* Performs auto adjustment
MANUAL SEARCH FORWARD/REVERSE	* Moves pickup

- How to check the test mode

- (1) DISC discrimination, adjustment

- * Insert DISC, and press the PAUSE button.
 - * “06 Adj” is displayed, and discrimination of DISC size 8 cm/12 cm, discrimination of DISC reflectance (CD, CD-R/CD-RW), adjustment of focus, tracking offset, and EF balance will be performed. (Adjusted values are not displayed: Refer to Fig. 2, 3)

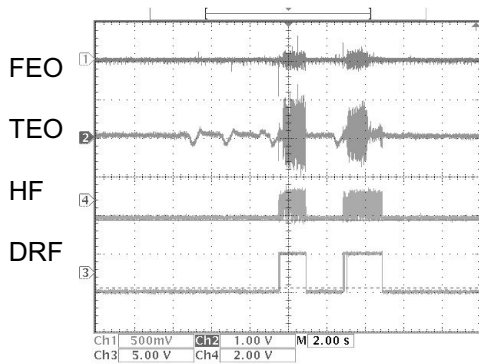

Fig. 2 DISC discrimination, adjustment
(Case of CD-RW)

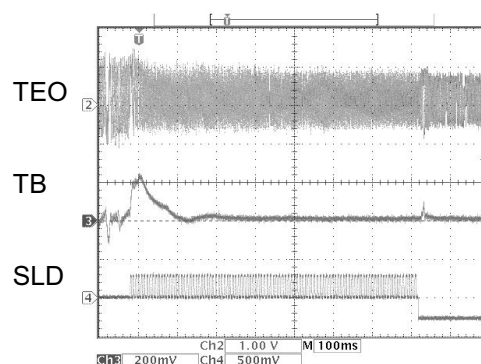

Fig. 3
Adjustment of EF balance

- * After completing the discrimination and adjustment, it becomes stop condition.
 - * Once discrimination of DISC has been carried out in the “06 Adj” mode, discrimination of size and reflectance is no longer made, and only adjustment will be performed.

- (2) Checking of servo state

- * Press the PLAY button after performing above (1) “DISC discrimination, adjustment”.
 - * “02 L on” is displayed, and the laser will start to light. (The pickup may vibrate with a rattling noise if DISC has been loaded, but this is not abnormal.)
 - * Press the PLAY button again.
 - * “03 F on” is displayed. DISC starts turning, and focus servo will be actuated. (Refer to Fig. 4, 5)

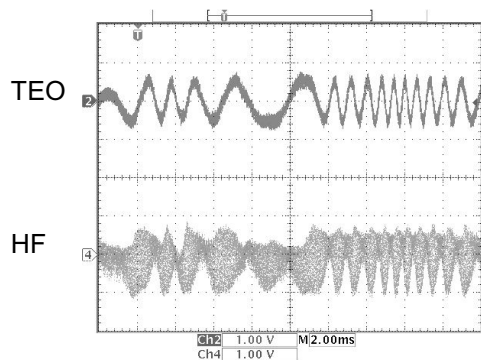
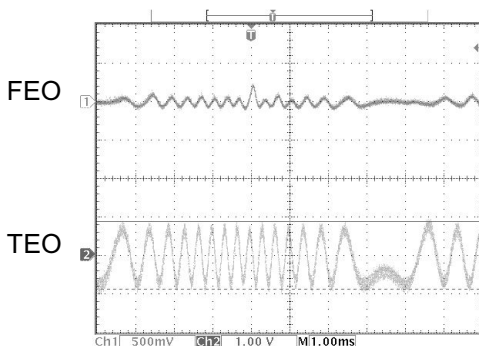

Fig. 4 In “03 F on”

Fig. 5 In “03 F on”

- * Press the PLAY button again.
- * “04 t on” is displayed. Tracking, CLV, and slide servo will be actuated.
- * Monitor HF signal using the test terminals, HF of CX053 (Pin No. ①) and VC of CX063 (Pin No. ⑤) : 2.5V ref. signal). Check that the signal’s amplitude is $1.5V \pm 0.3V_{p-p}$. (Refer to Fig. 6)

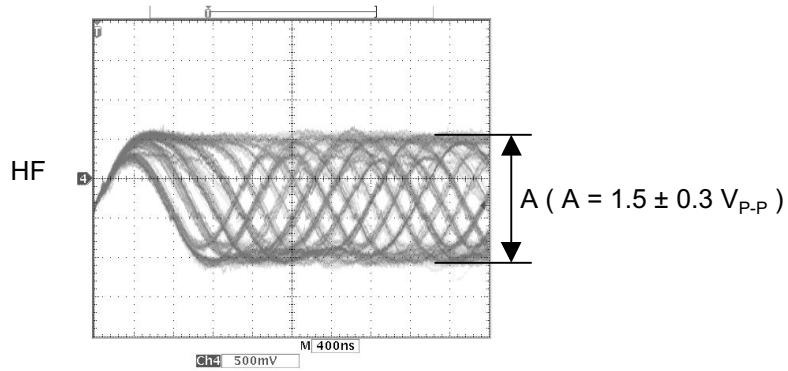
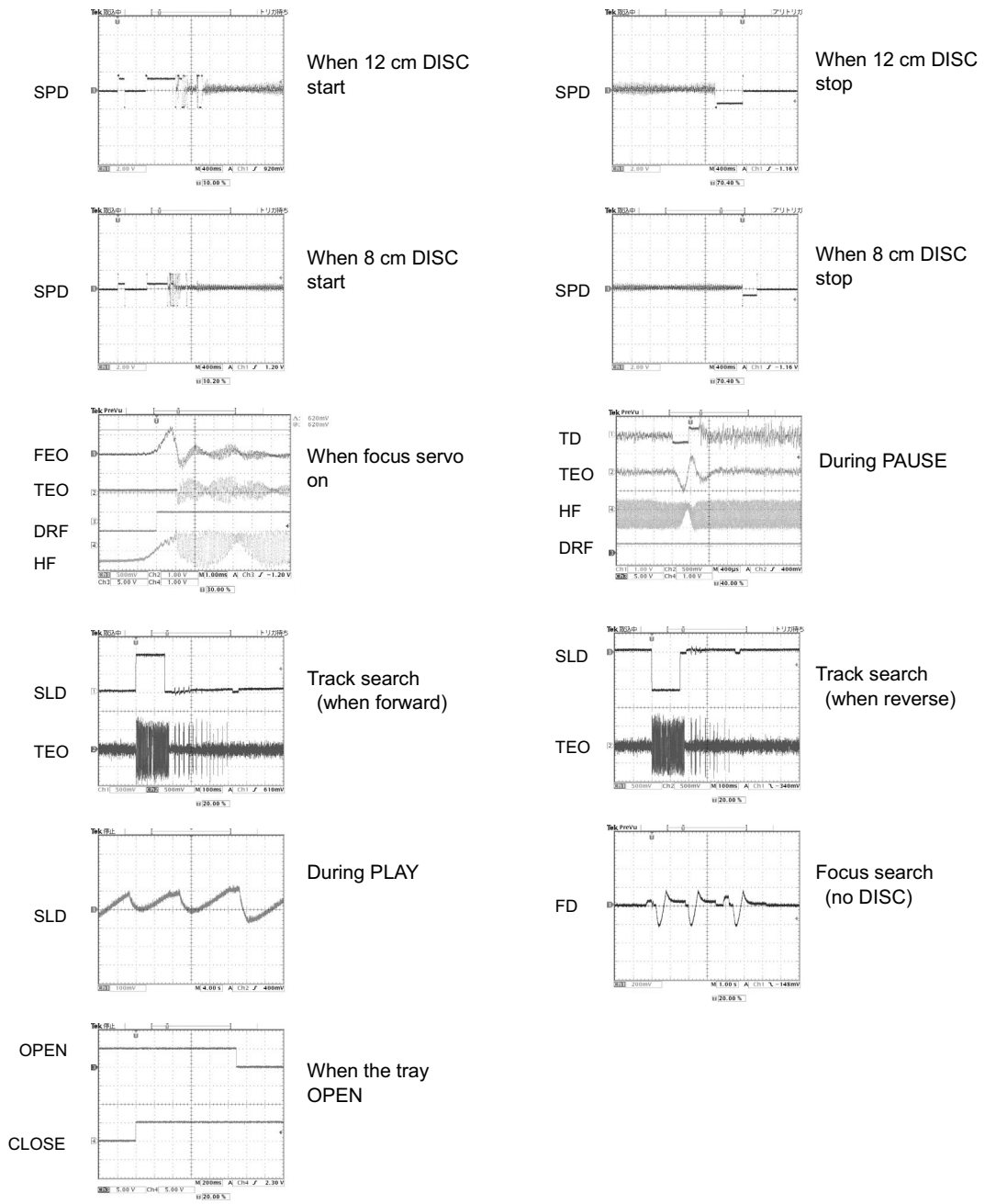
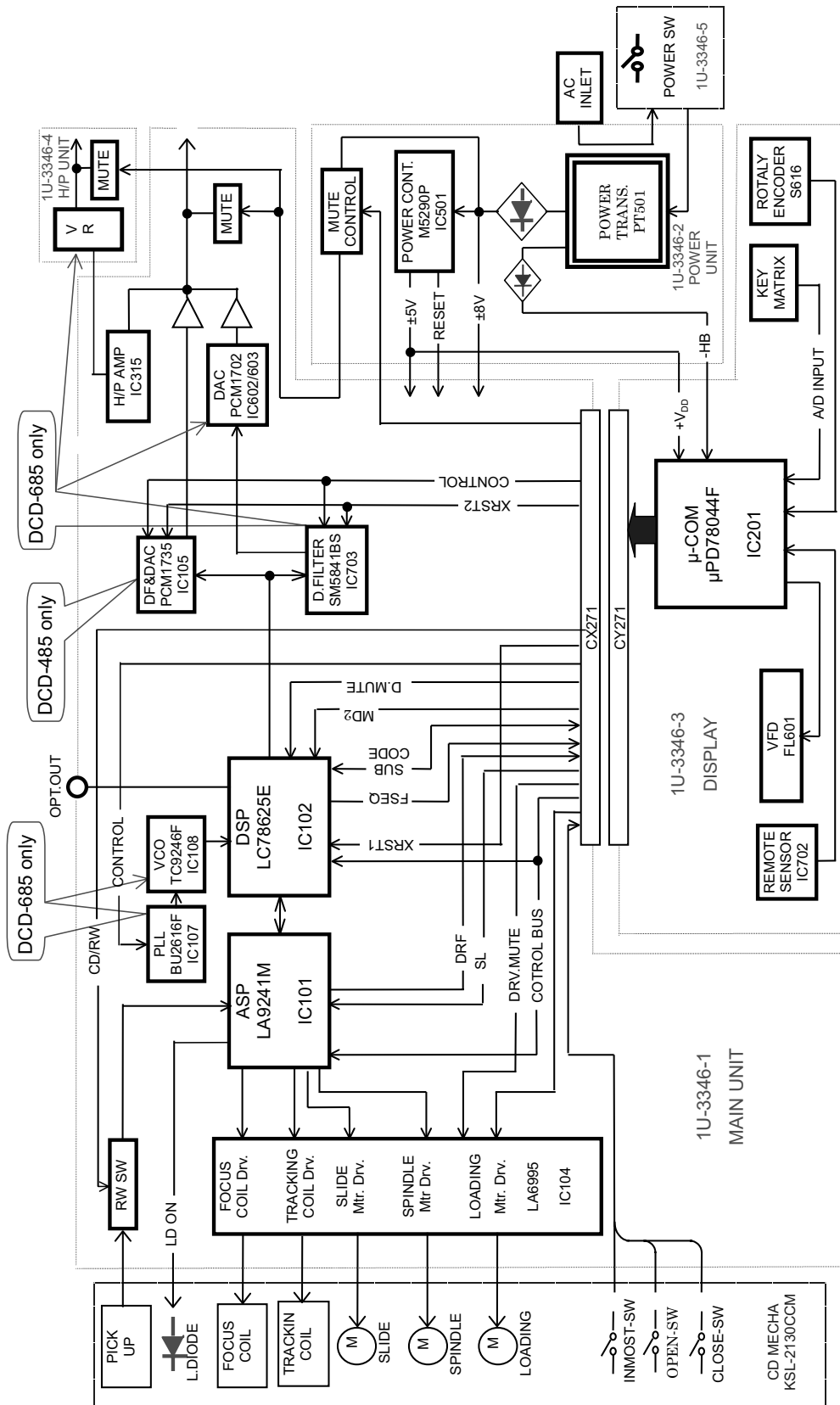

Fig. 6 In “04 t on”

Wave-forms of each point



BLOCK DIAGRAM



NOTE FOR HANDLING OF LASER PICK-UP

• Description of the Components

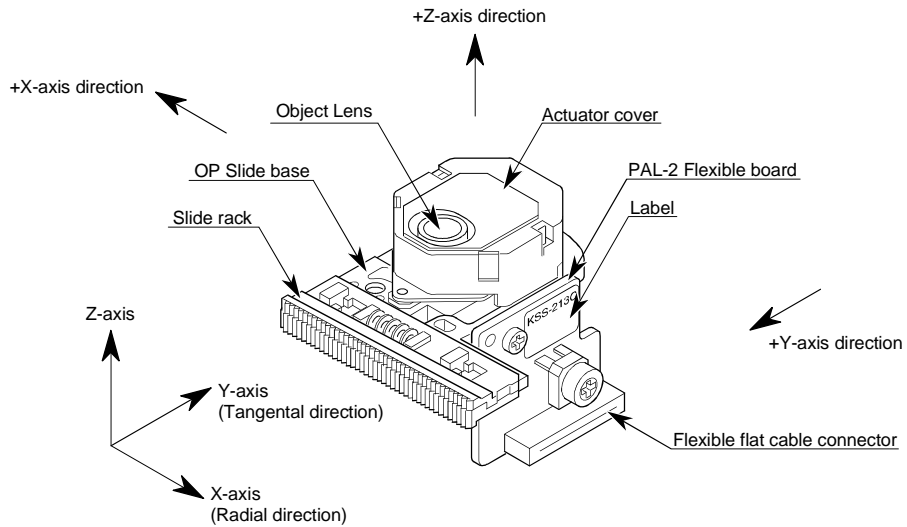

• Label

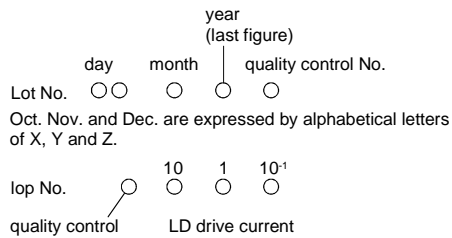
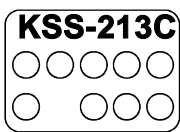

The expressed unit is by mA, with omission of the decimal point as for example, 56.5mA will be expressed as 565, but the head of English letter means the control in the manufacturing plant.

• Pin Connector

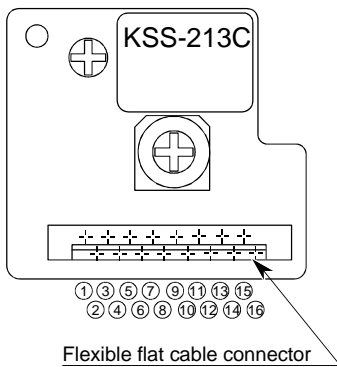

Pin No.	Description	IN/OUT	Pin No.	Description	IN/OUT
1	PD IC Vc	IN	9	LD PDIC GND	IN
2	Vcc	IN	10	LD LD	IN
3	E	OUT	11	VR	IN
4	D	OUT	12	PD	OUT
5	A	OUT	13	FCS (+)	IN
6	B	OUT	14	TRK (+)	IN
7	C	OUT	15	TRK (-)	IN
8	F	OUT	16	FCS (-)	IN

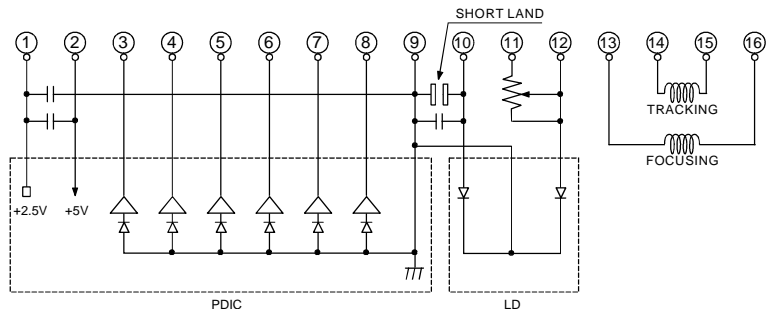

• **CAUTION:** The soldered connecting portion must be bridged when removing CX161.

● Caution for Handling the Laser Pick-up

The laser pick-up KSS-213C is assembled and precisely adjusted using a sophisticated manufacturing process in our plant. Do not disassemble or attempt to readjust it. Please observe the following instructions carefully in handling the pick-up.

1. Handle with Care

- (1) Storage
Do not store the pick-up in dusty, high-temperature or high-humidity environments.
- (2) Please take care for preventing from shock by falling down or careless handling.

2. Laser Diode (LD)

- (1) Protect your eyes
The laser beam may damage the human eye, since the intensity of the focused spot may reach 7×10^3 W/cm² even if the intensity at the objective lens is 400μW maximum. As the light beam spreads after focused through the objective lens, it does not effect you in the place as far as more than 30 cms. However, do not look at the laser light beam either through the objective lens directly nor another lens or a mirror.
- (2) Poison of As
Since the LD chip contains As (Arsenic), as GaAs + GaAlAs, as known as the poison, although the poison is relatively weak, in comparing with others, e.g. As₂O₃, AsCl₃ etc., and the amount is small, avoid putting the chip in acid or an alkali solution, heating it over 200 °C or putting it into your mouth.
- (3) Avoid surge current or electrostatic discharge
The LD may be damaged or deteriorated by its own strong light if a large current is supplied to it, even if only a short pulse.
Make sure that there is no surge current in the LD driving circuit by switches or else. Be careful to handle pick-up as it may be damaged in a moment by human electrostatic discharge. The pins of the LD are short-circuited by solder for protection during shipment.
For safety handling of an LD, grounding the human body, measuring equipments and jig is strongly recommended. And still it is further desirable to make use of mat on the platform and floor for handling the LD.
To open the short-circuit, remove the soldering quickly with a soldering iron whose metal part is grounded.
The temperature of the soldering iron should be less than 320°C (30W).

3. Actuator

- (1) The performance of the actuator may be affected if magnetic material is located nearby, since the actuator has a strong magnetic circuit. Do not permit dust to enter through the clearance of the cover.
- (2) Cleaning the lens
It may change the specifications by attaching dust or ash on the objective lens. Clean the lens with a cleaning paper dampened with, not pressing lens with so much strength by the cleaning paper.

4. Metal Bearing

As the metal bearing of Cu-compound sintered alloy is impregnated with FROIL946P, never fail to supply the bushing with the same lubricant at the time of replacing the pick-up.

5. Handling

Please handle the laser pick-up with holding the slide base. (resin molded part).
When either a part of human body or some other things may happen to touch directly with the circuit part of P.W.Board, it may cause deterioration, take careful attention in handling this base.

6. Deterioration

As KSS-213C comprises built-in RF Amp and APC circuit, resists stronger against external electrostatic damages than the former typed pickup. However, there is possibility of pickup deterioration in the following cases.
(1) Low HF level, or with great numbers of jitters.
(2) Tracking offset (EF Balance) is out of order (Refer to "Confirmation Method of Adjustment" for confirmation (1) and (2)).

SEMICONDUCTORS

IC's

µPD78044FGF-188-3B9 (IC601)

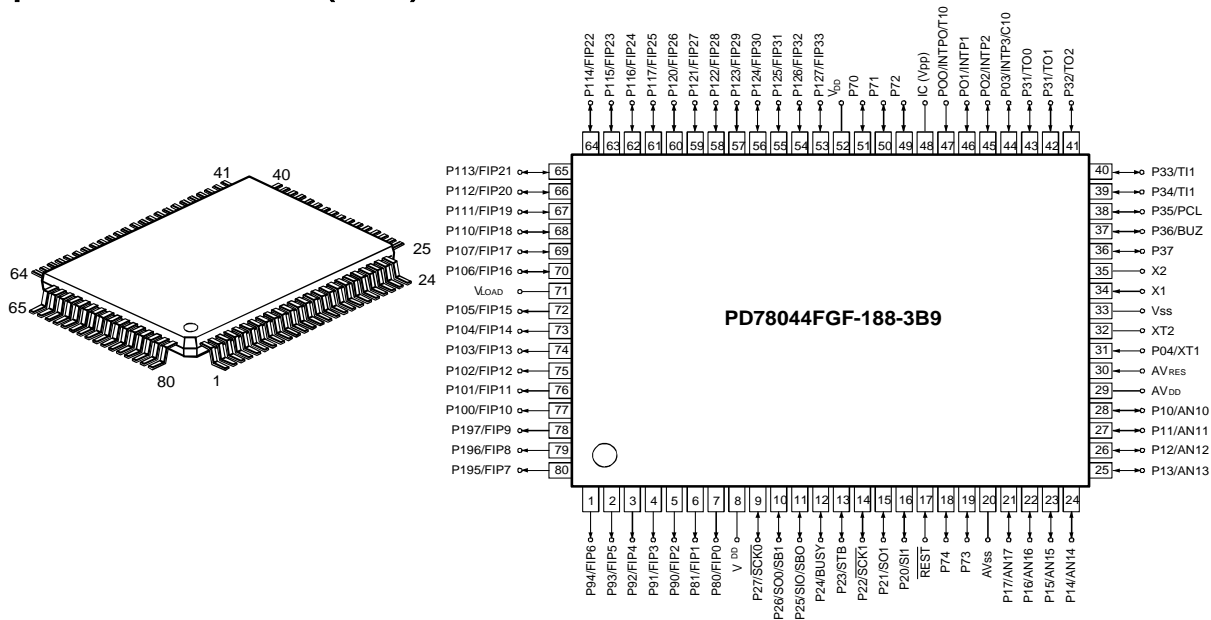

µPD78044FGF-188-3B9 Terminal Function

Pin No.	Terminal	Port	I/O	Typ	Rst	Ini	Act	Ext	Function
1	P94/FIP6	NC	O	C	Hz	-	-	-	Not used (Open)
2	P93/FIP5	6G	O	C	Hz	L	H	P. D	VFD grid 6G (EMPHASIS, PLAY, PAUSE, REPEAT)
3	P92/FIP4	5G	O	C	Hz	L	H	P. D	VFD grid 5G (11~20, A-B, PROG, ●)
4	P91/FIP3	4G	O	C	Hz	L	H	P. D	VFD grid 4G (1~10)
5	P90/FIP2	3G	O	C	Hz	L	H	P. D	VFD grid 3G (Seconds Digit, S, SINGLE)
6	P81/FIP1	2G	O	C	Hz	L	H	P. D	VFD grid 2G (Minutes Digit, M, TOTAL)
7	P80/FIP0	1G	O	C	Hz	L	H	P. D	VFD grid 1G (Track No., A.SPACE)
8	V _{DD}	V _{DD}	-	-	-	-	-	-	Positive power (Connect to +5V)
9	P27/SCK0	MCK	O	B	Hz	H	↑	P. UP	SM5841/PCM1735/BU2616 mode control clock output
10	P26/S00/SB1	MDT	O	B	Hz	-	-	P. UP	SM5841/PCM1735/BU2616 mode control data output
11	P25/SI0/SB0	NC	I	B	Hz	-	-	P. DG	Not used (Connect to GND)
12	P24/BUSY	NC	I	B	Hz	-	-	P. DG	Not used (Connect to GND)
13	P23/STB	MLE	O	B	Hz	-	↑	P. UP	SM5841/PCM1735 mode control latch output
14	P22/SCK1	CQCK	O	B	Hz	-	↑	-	DSP, ASP Command clock & SUBQ readout clock output
15	P21/SO1	COIN	O	B	Hz	-	-	-	DSP, ASP Command data output
16	P20/SI1	SUBQ	I	B	Hz	-	-	-	DSP sub-code Q data input
17	RESET	RESET	I	-	-	-	L	-	Reset signal input
18	P74	NC	I	B	Hz	-	-	P. DG	Not used (Connect to GND)
19	P73	XTAL	O	B	Hz	H	L	P. UP	TC9246XTAL MODE change Lo:ON (Pitch 0), Hi:OFF (Variable pitch)
20	AV _{SS}	AV _{SS}	-	-	-	-	-	-	GND for A/D converter
21	P17/ANI7	DSP X _{RST}	O	B	Hz	L	L	P. DG	DSP reset signal output
22	P16/ANI6	DF X _{RST}	O	B	Hz	L	L	P. DG	Digital filter reset signal output
23	P15/ANI5	JOG B	I	B	Hz	-	-	P. UP	Rotary encoder JOG B input
24	P14/ANI4	JOG A	I	B	Hz	-	-	P. UP	Rotary encoder JOG A input
25	P13/ANI3	AD3	I	B	Hz	-	A	P. UP	Key data input 3 (A/D)
26	P12/ANI2	AD2	I	B	Hz	-	A	P. UP	Key data input 2 (A/D)
27	P11/ANI1	AD1	I	B	Hz	-	A	P. UP	Key data input 1 (A/D)
28	P10/ANI0	AD0	I	B	Hz	-	A	P. UP	Key data input 0 (A/D)
29	AV _{DD}	AV _{DD}	-	-	-	-	-	-	A/D converter analog power (Connect to +5V)
30	AV _{REF}	AV _{REF}	I	-	-	-	-	-	A/D converter Ref. V input (Connect to +5V)

Pin No.	Terminal	Port	I/O	Typ	Rst	Ini	Act	Ext	Function
31	P04/XT1	NC	I	A	-	-	-	P. DG	Not used (Connect to GND)
32	XT2	NC	-	-	-	-	-	-	Not used (Open)
33	Vss	GND	-	-	-	-	-	-	GND
34	X1	X1	I	A	-	-	-	-	Main system clock input
35	X2	X2	-	-	-	-	-	-	Main system clock input
36	P37	MCS	O	B	Hz	H	L	P. DG	PCM1735 chip select output
37	P36/BUZ	MCE	O	B	Hz	L	L	-	BU2616 chip enableoutput
38	P35/PCL	RWC	O	B	Hz	L	L	-	DSP read / write control output
39	P34/TI2	SL+	O	B	Hz	L	H	-	ASP sled drive signal output
40	P33/TI1	SL-	O	B	Hz	L	H	-	ASP sled drive signal output
41	P32/T02	NC	I	B	Hz	-	-	P. DG	Not used (Connect to GND)
42	P31/T01	CD/RW	O	B	Hz	H	L	P. DG	CD / RW Gain change output
43	P30/T00	SEARCH	O	B	Hz	L	H	P. DG	Servo control output at search
44	P03/INTP3/CI0	REMOCON	I	B	Hz	-	↑	-	Remote control signal input
45	P02/INTP2	WRQ	I	B	Hz	L	H	-	DSP SUBQ output standby input
46	P01/INTP1	DRF	I	B	Hz	L	H	-	ASP DEFECT RF level detect input
47	P00/INTP0/TI0	NC	I	A	Hz	-	-	P. UP	Not used (Connect to GND)
48	IC	IC	-	-	-	-	-	-	Connect to GND
49	P72	FSEQ	I	B	Hz	L	H	-	DSP sync signal detect input
50	P71	A.MUTE	O	B	Hz	H	H	P. UP	Analog mute output OFF: Lo, ON: Hi
51	P70	DRV.MUTE	O	B	Hz	H	-	P. UP	MOTOR DRIVER MUTE control output Hi:Output ON
52	VDD	VDD	-	-	-	-	-	-	Positive power (Connect to +5V)
53	P127/FIP33	OPSW	I	C	Hz	-	L	P. UP	Loader open position detect switch input
54	P126/FIP32	CLSW	I	C	Hz	-	L	P. UP	Loader close position detect switch input
55	P125/FIP31	INSW	I	C	Hz	-	L	P. UP	Pickup inner position detect switch input
56	P124/FIP30	OPEN	O	C	Hz	L	H	P. DG	Loader open drive LA6559 signal output
57	P123/FIP29	CLOSE	O	C	Hz	L	H	P. DG	Loader close drive LA6559 signal output
58	P122/FIP28	MODEL	I	C	Hz	-	-	-	Model distinction input Lo:455, Hi:555
59	P121/FIP27	NC	I	C	Hz	-	-	P. DG	Not used (Open)
60	P120/FIP26	NC	I	C	Hz	-	-	P. DG	Not used (Open)
61	P117/FIP25	P1	O	C	Hz	L	H	P. D	VFD segment P1 (1a, 1, 11, EMPHASIS)
62	P116/FIP24	P2	O	C	Hz	L	H	P. D	VFD segment P2 (1b, 2, 12, PLAY)
63	P115/FIP23	P3	O	C	Hz	L	H	P. D	VFD segment P3 (1c, 3, 13, PAUSE)
64	P114/FIP22	P4	O	C	Hz	L	H	P. D	VFD segment P4 (1d, 4, 14, REPEAT)
65	P113/FIP21	P5	O	C	Hz	L	H	P. D	VFD segment P5 (1e, 5, 15)
66	P112/FIP20	P6	O	C	Hz	L	H	P. D	VFD segment P6 (1f, 6, 16)
67	P111/FIP19	P7	O	C	Hz	L	H	P. D	VFD segment P7 (1g, 7, 17)
68	P110/FIP18	P8	O	C	Hz	L	H	P. D	VFD segment P8 (2a, 8, 18)
69	P107/FIP17	P9	O	C	Hz	L	H	P. D	VFD segment P9 (2b, 9, 19)
70	P106/FIP16	P10	O	C	Hz	L	H	P. D	VFD segment P10 (2c, 10, 20)
71	V _{LOAD}	-HB	I	C	-	-	-	-	Power for FL display (-HB)
72	P105/FIP15	P11	O	C	Hz	L	H	P. D	VFD segment P11 (2d, A-B)
73	P104/FIP14	P12	O	C	Hz	L	H	P. D	VFD segment P12 (2e, PROG)
74	P103/FIP13	P13	O	C	Hz	L	H	P. D	VFD segment P13 (2f, ●)
75	P102/FIP12	P14	O	C	Hz	L	H	P. D	VFD segment P14 (2g)
76	P101/FIP11	P15	O	C	Hz	L	H	P. D	VFD segment P15 (A.SPACE, TOTAL, SINGLE)
77	P100/FIP10	P16	O	C	Hz	L	H	P. D	VFD segment P16 (M, S)
78	P97/FIP9	NC	O	C	Hz	-	-	-	Open (Not used)
79	P96/FIP8	NC	O	C	Hz	-	-	-	Open (Not used)
80	P95/FIP7	NC	O	C	Hz	-	-	-	Open (Not used)

Type A: Standard input port

B: Standard in/output port

C: Hi-voltage proof in/output port

D: P-ch open drain hi-voltage proof

Note) P.D: Pull-down to VDISP

P.DG: Pull-down to GND

LA6559 (IC101)

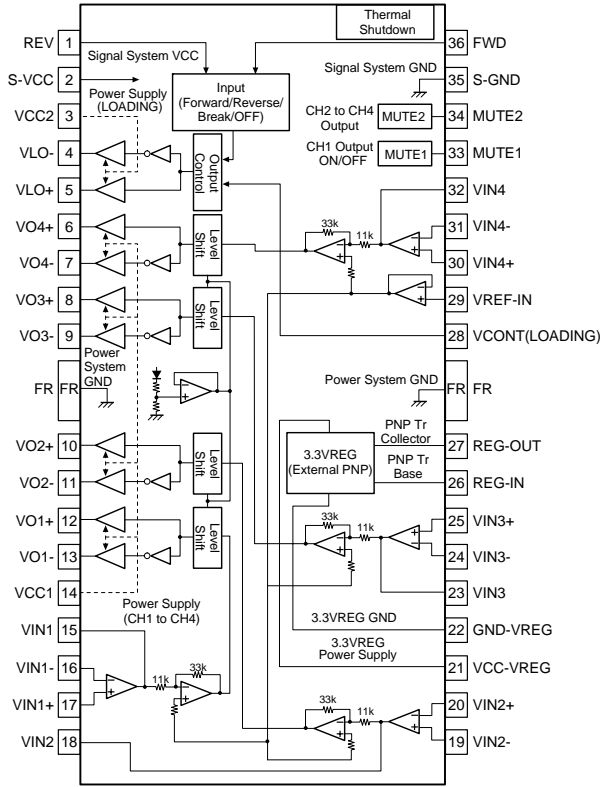

Pin No.	Name	Function
1	REV	5CH output change terminal, logic input of loading block
2	S-Vcc	signal system power supply (BTL-AMP:CH1-4)
3	Vcc2	Power supply for loading block
4	VL0-	Loading output (-)
5	VL0+	Loading output (+)
6	VO4+	Output terminal (+) for channel 4
7	VO4-	Output terminal (-) for channel 4
8	VO3+	Output terminal (+) for channel 3
9	VO3-	Output terminal (-) for channel 3
10	VO2+	Output terminal (+) for channel 2
11	VO2-	Output terminal (-) for channel 2
12	VO1+	Output terminal (+) for channel 1
13	VO1-	Output terminal (-) for channel 1
14	Vcc1	CH1•CH4(BTL-AMP) output stage power supply
15	VIN1	Input terminal for channel 1
16	VIN1-	OP-AMP input AMP-A input terminal (-)
17	VIN1+	OP-AMP input AMP-A input terminal (+)
18	VIN2	Input terminal for channel 2, input AMP output
19	VIN2-	Input terminal (-) for channel 2
20	VIN2+	Input terminal (+) for channel 2
21	Vcc-VREG	3.3VREG power supply
22	GND-VREG	3.3VREG GND
23	VIN3	Input terminal for channel 3, input AMP output
24	VIN3-	Input terminal (-) for channel 3
25	VIN3+	Input terminal (+) for channel 3
26	REG-IN	PNP transistor base connected
27	REG-OUT	3.3V power output to which the PNP transistor collector connected
28	VCONT	Loading output voltage set terminal
29	VREF-IN	Reference voltage applied terminal
30	VIN4+	Input terminal (+) for channel 4
31	VIN4-	Input terminal (-) for channel 4
32	VIN4	Input terminal for channel 4, input AMP output
33	MUTE1	Output ON/OFF for channel 1 (BTL AMP)
34	MUTE2	Output ON/OFF for channel 2 to 4 (BTL AMP)
35	S-GND	Signal system GND
36	FWD	Output change terminal (FWD) for loading output (VLO+/-), logic input of loading block

LA9241M (IC103)

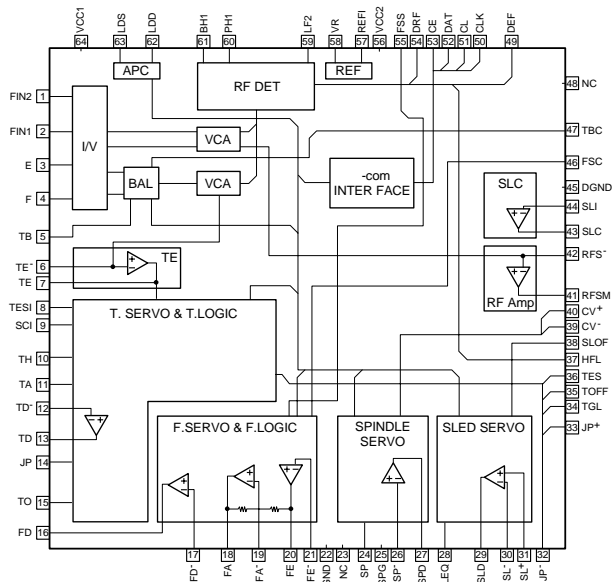
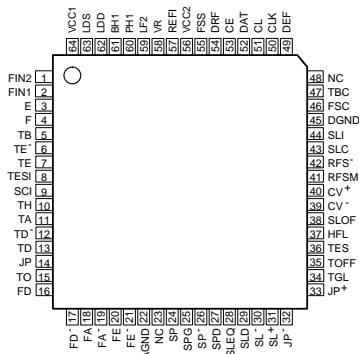

PCM1735E
(for DCD-485 : IC301)

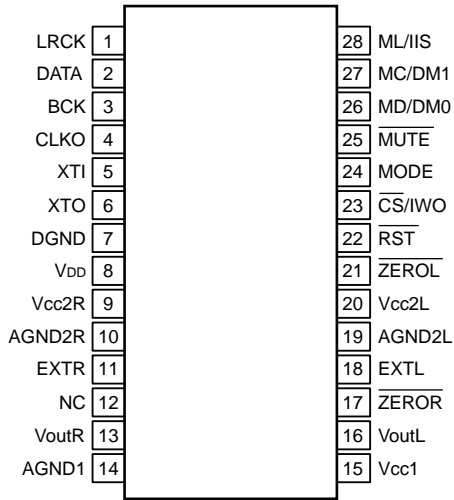

PCM1735E Terminal Function

Pin No.	Name	I/O	Function
1	LRCK	I	LRCK clock input (fs)
2	DATA	I	Data input
3	BCK	I	Bit clock input for data
4	CLKO	O	System clock, buffer output
5	XTI	I	X'tal oscillator connect or ext. clock input
6	XTO	O	X'tal oscillator connect
7	DGND	-	Digital GND
8	V _{DD}	-	Digital power supply +5V
9	V _{CC2R}	-	Analog power supply +5V
10	AGND2R	-	Analog GND
11	EXTR	O	Rch analog out amp, common
12	NC	-	NC
13	VoutR	O	Rch analog V-out
14	AGND1	-	Analog GND
15	V _{CC1}	-	Analog power supply +5V
16	VoutL	O	Lch analog V-out
17	ZEROR	O	Rch zero-data flag (open drain)
18	EXTL	O	Lch analog out amp, common
19	AGND2L	-	Analog GND
20	V _{CC2L}	-	Analog power supply +5V
21	ZEROL	O	Lch zero-data flag (open drain)
22	RST	I	Reset, L:DF and Δ - Σ modulator reset
23	CS/IWO	I	Chip select/Input format select
24	MODE	I	Mode control select (H: Soft, L: Hard)
25	MUTE	I	Mute control
26	MD/DM0	I	Mode cont. data/De-emphasis select 1
27	MC/DM1	I	Mode cont. BCK/De-emphasis select 2
28	ML/IIS	I	Mode cont. latch/Input format select

BU2616F (E2) (for DCD-685 : IC102)

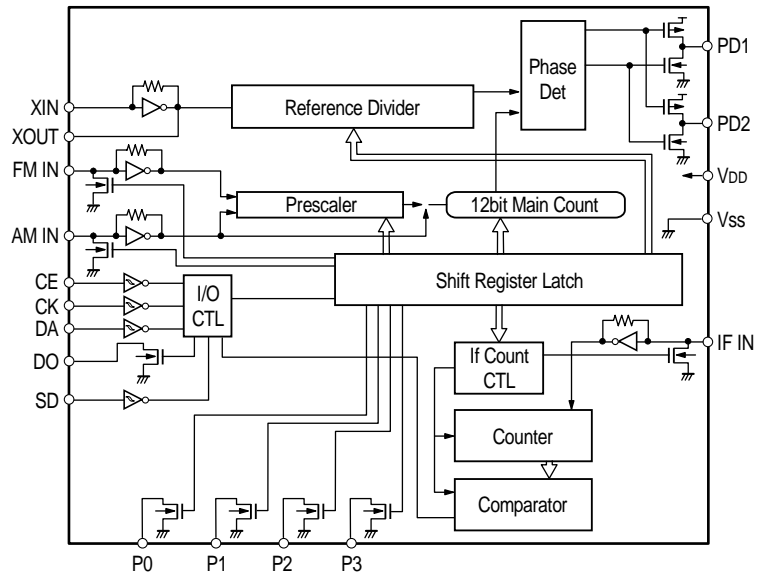
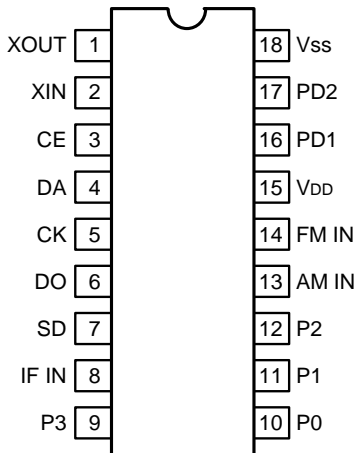

LC78625E (IC106)

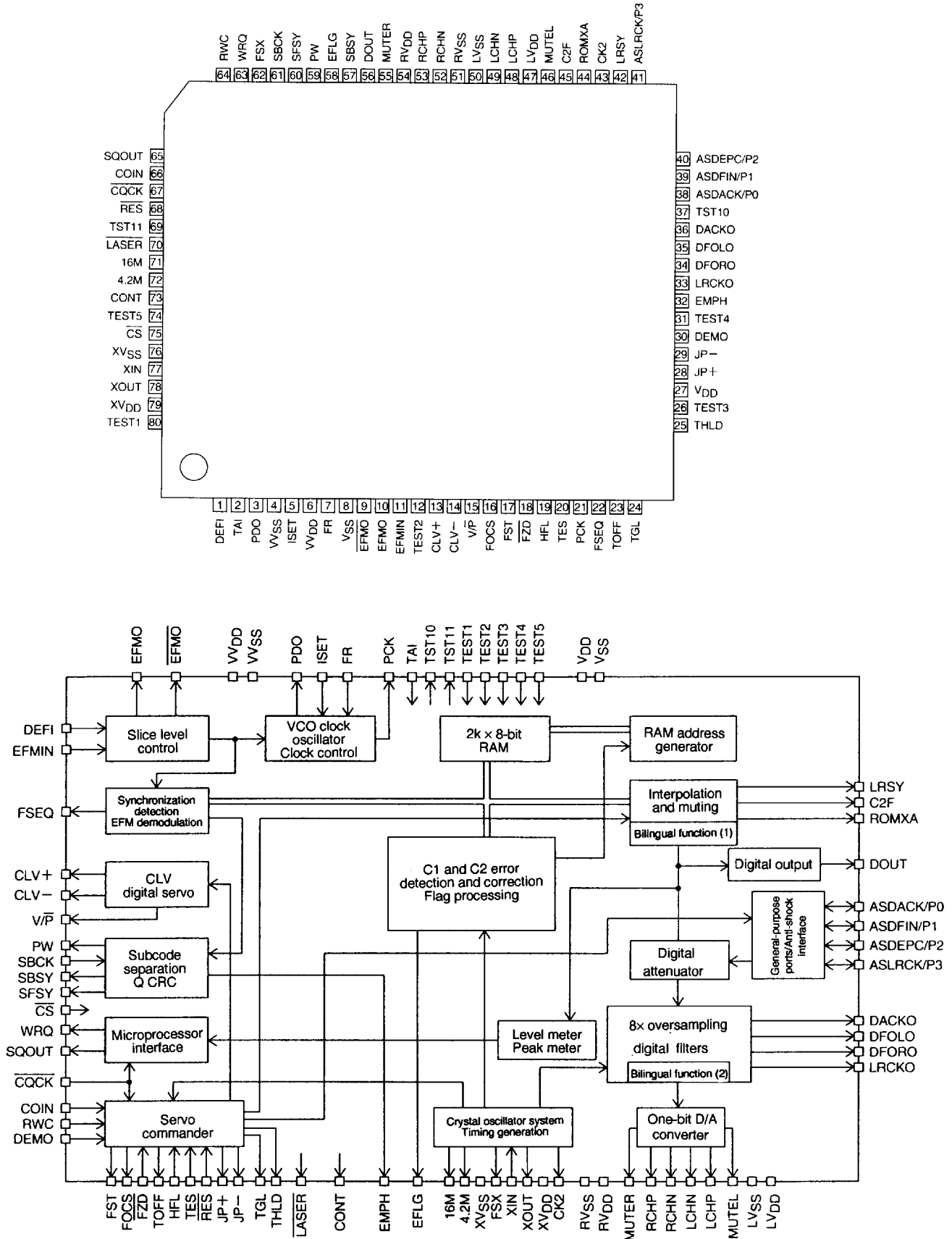

M5290FP (IC502)

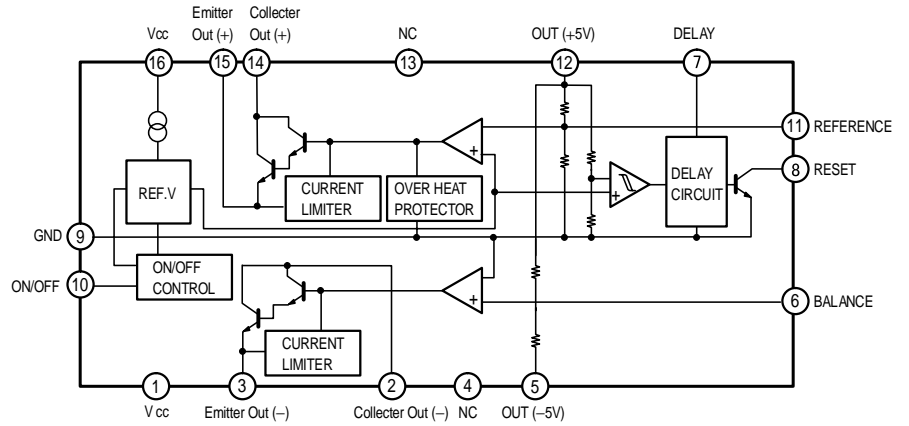
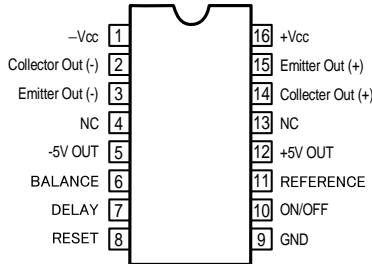

TC9246F (for DCD-685 : IC104)

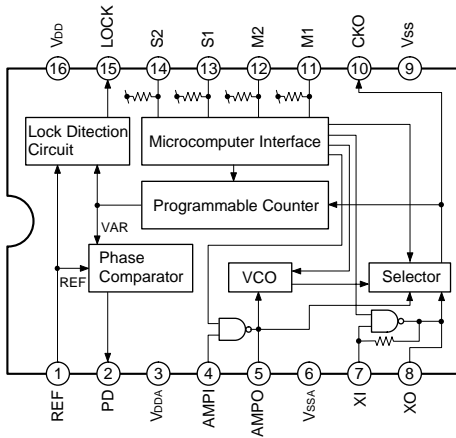

TC7WU04F (IC107)

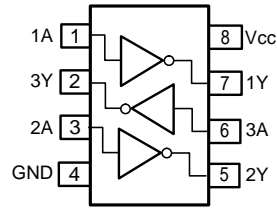

SM5841BS (for DCD-685 : IC304)

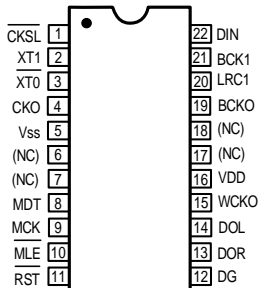

PCM1702P (for DCD-685 : IC321,322)

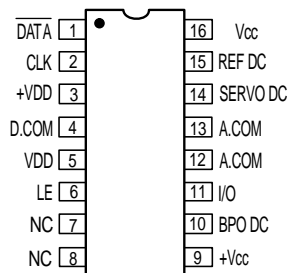

μPC4570C (IC325)

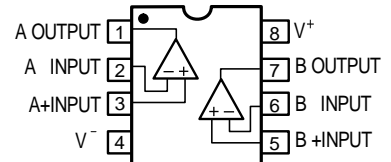

**BA15218F (for DCD-485 : IC303)
(for DCD-685 : IC323, 324)**

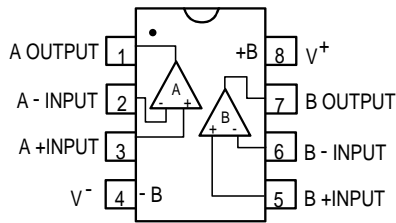

● IC PROTECTOR

ICP-N20 (IC503)

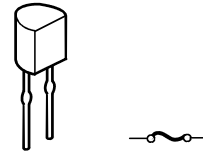

● TRANSISTORS

2SB562 (C)

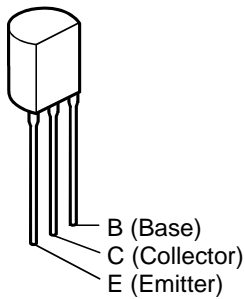

**2SB1185 (E/F)
2SD1762 (E/F)**

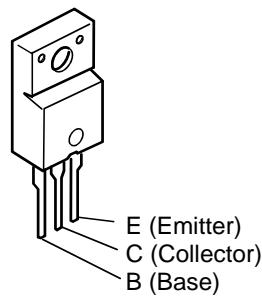

2SD2144S

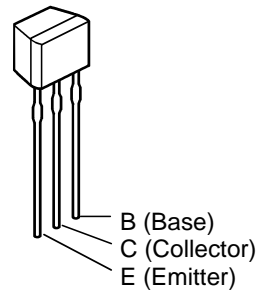

**2SA1037K (S/R)
2SC3326 (for DCD-485)**

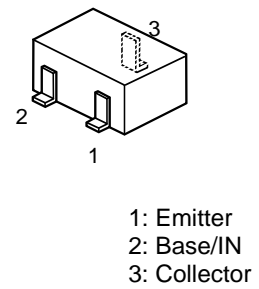

- DTA124XKA } PNP TYPE
- DTA144EK } PNP TYPE
- DTC114EK } NPN TYPE
- DTC144EK } NPN TYPE
- DTC144TK } NPN TYPE

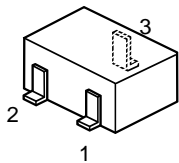

- 1: E/GND
- 2: B/INPUT
- 3: C/OUTPUT

PNP TYPE

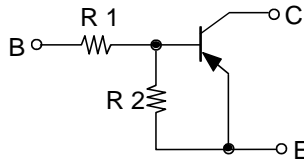

	R1	R2
DTA124XKA	22kohm	47kohm
DTA144EK	47kohm	47kohm

NPN TYPE

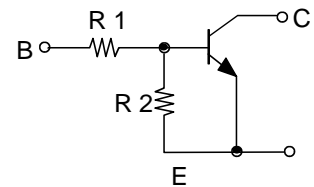

	R1	R2
DTC114EK	10kohm	10kohm
DTC144EK	47kohm	47kohm
DTC144TK	47kohm	OPEN

● DIODES

1SS270A

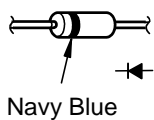

1SR35-400A

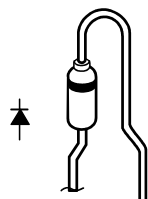

**MTZJ24A
MTZJ6.8A
HZS2B-1 (for DCD-685)**

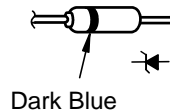

● OPTICAL TERMINAL

TOTX179 (JK201)

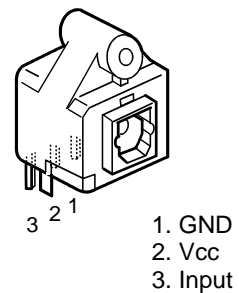

● Remote Control Sensor
GP1U271X (IC601)

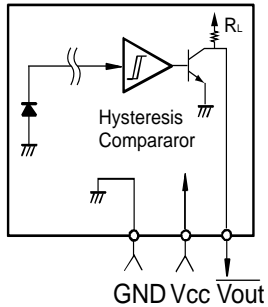
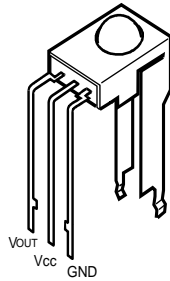

● FL DISPLAY 6-ST-33GK

(Part No. : 393 8021 006)

Anode Connection

	1G	2G	3G	4G	5G	6G
P1	1a	1a	1a	1	11	EMPHASIS
P2	1b	1b	1b	2	12	▶PLAY
P3	1c	1c	1c	3	13	▬▬PAUSE
P4	1d	1d	1d	4	14	REPEAT
P5	1e	1e	1e	5	15	-
P6	1f	1f	1f	6	16	-
P7	1g	1g	1g	7	17	-
P8	2a	2a	2a	8	18	-
P9	2b	2b	2b	9	19	-
P10	2c	2c	2c	10	20	-
P11	2d	2d	2d	-	A-B	-
P12	2e	2e	2e	-	PROG	-
P13	2f	2f	2f	-	○	-
P14	2g	2g	2g	-	-	-
P15	A.SPACE	TOTAL	SINGLE	-	-	-
P16	-	M	S	-	-	-

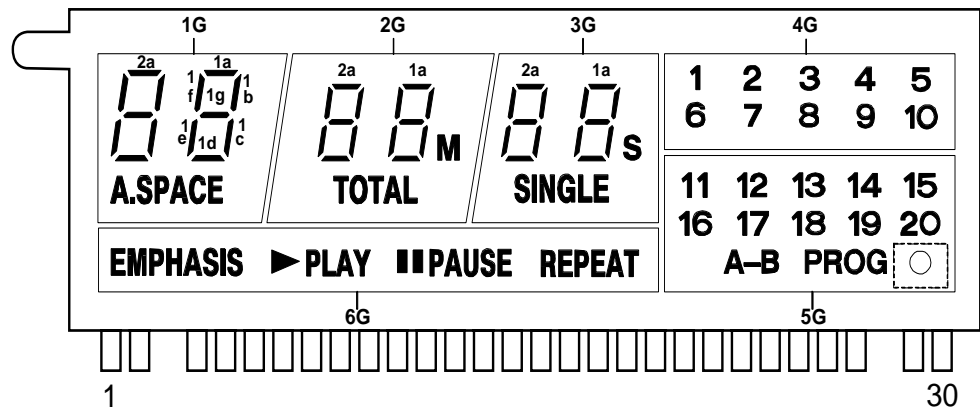

Pin Connection

Pin No.	1	2	3	4	5	6	7	8	9	10	11	12	13	14	15
Connection	F1	F1	NP	1G	2G	3G	4G	5G	6G	NX	NX	P16	P15	P14	P13

Pin No.	16	17	18	19	20	21	22	23	24	25	26	27	28	29	30
Connection	P12	P11	P10	P9	P8	P7	P6	P5	P4	P3	P2	P1	NP	F2	F2

Note: 1) F1, F2- - - - - Filament

2) NP- - - - - No pin

3) P1~P16- - - - Anode

4) 1G~6G- - - - Grid

5) NX- - - - - No extend pin

6) Field of vision is a minimum of 29° from the upper side, 30° from the lower side.

**PRINTED WIRING BOARD
CD BOARD ASS'Y**

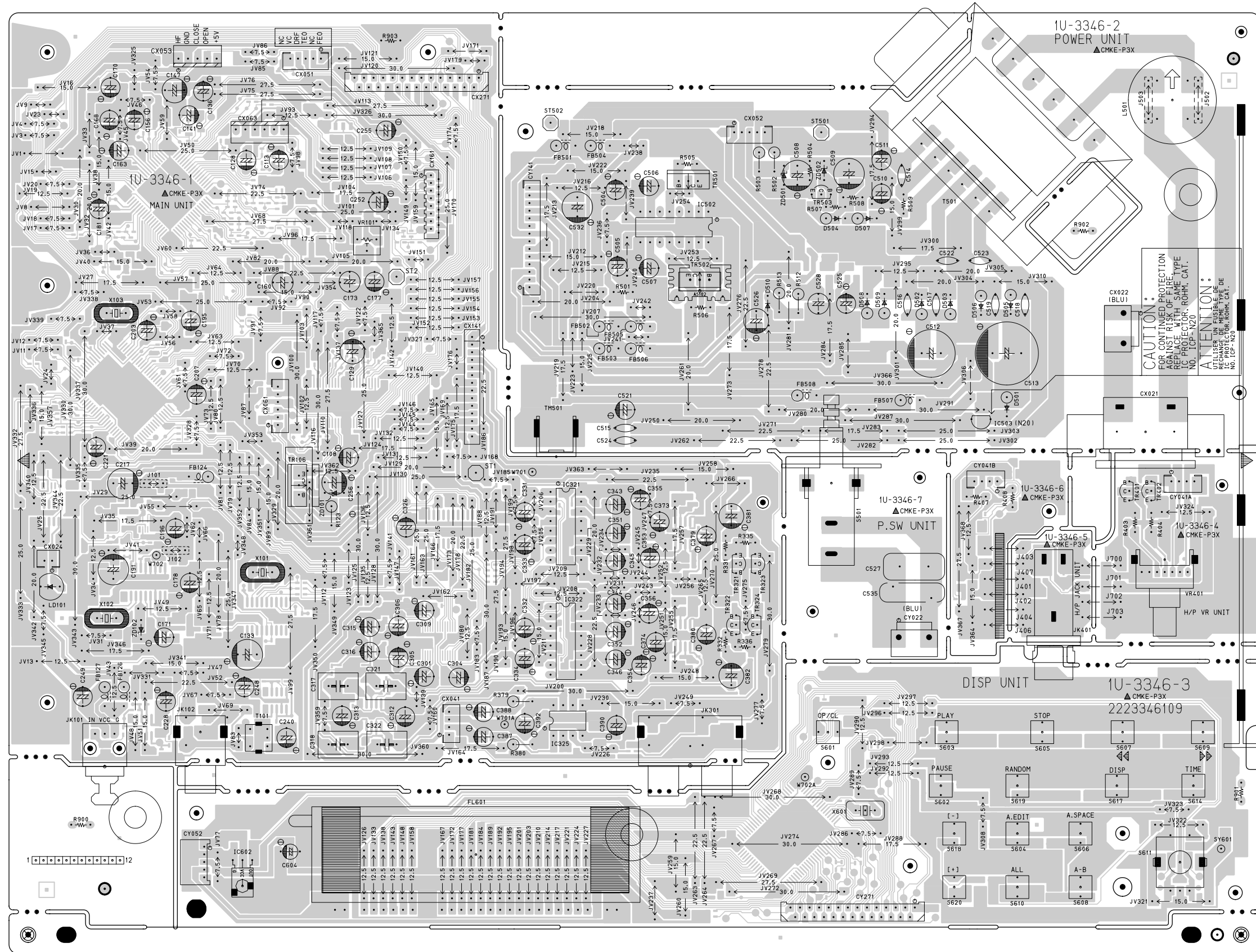

COMPONENT SIDE

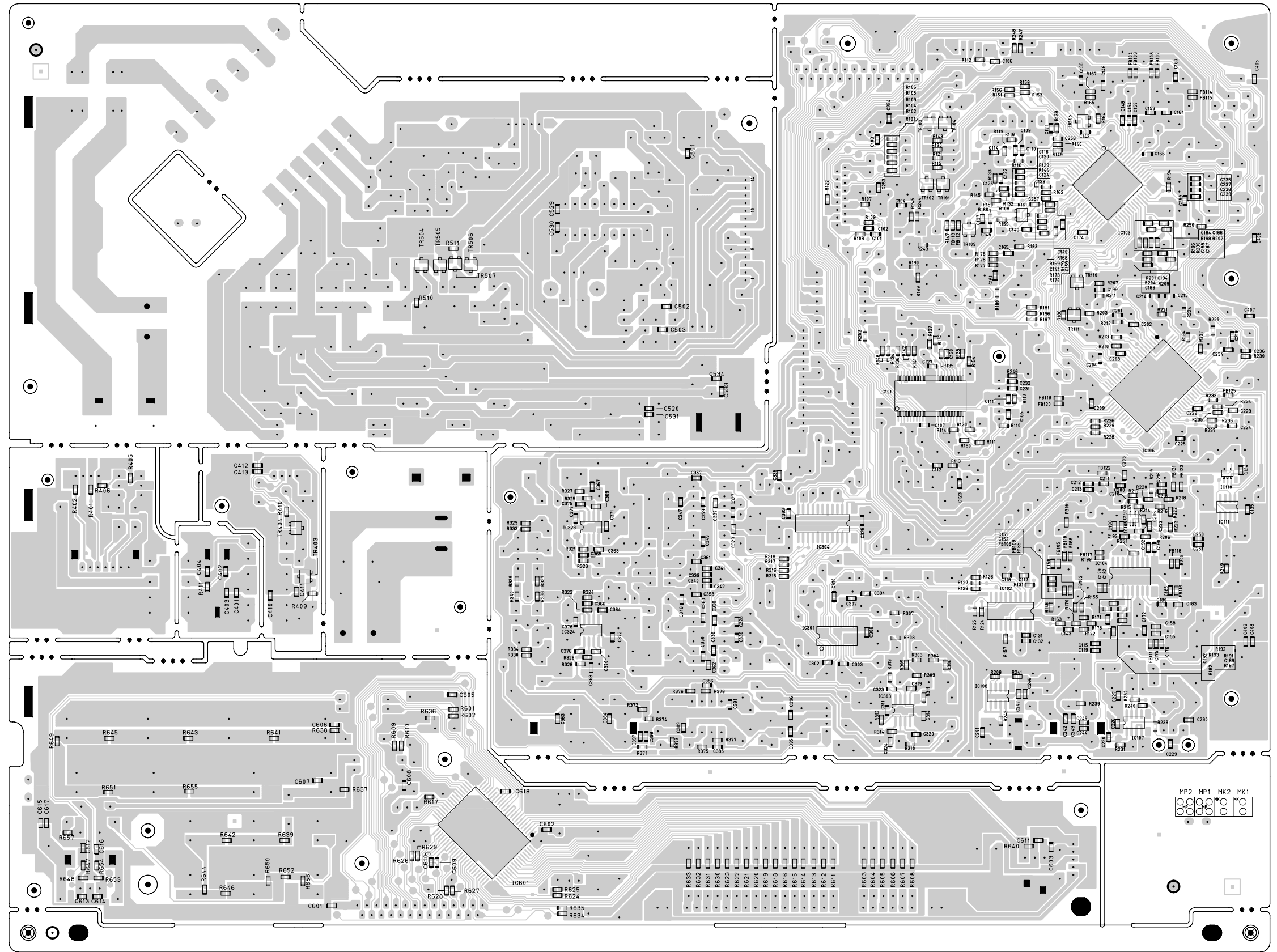

COPPER SIDE

NOTE FOR PARTS LIST

- Part indicated with the mark "⊙" are not always in stock and possibly to take a long period of time for supplying, or in some case supplying of part may be refused.
- When ordering of part, clearly indicate "1" and "I" (i) to avoid mis-supplying.
- Ordering part without stating its part number can not be supplied.
- Part indicated with the mark "★" is not illustrated in the exploded view.
- Not including Carbon Film ±5%, 1/4W Type in the P.W.Board parts list. (Refer to the Schematic Diagram for those parts.)

WARNING:

Parts marked with this symbol  have critical characteristics.
Use ONLY replacement parts recommended by the manufacturer.

● Resistors

Ex: RN 14K 2E 182 G FR
 Type Shape and performance Power Resistance Allowable error Others

RD : Carbon	2B : 1/8W	F : ±1%	P : Pulse-resistant type
RC : Composition	2E : 1/4W	G : ±2%	NL : Low noise type
RS : Metal oxide film	2H : 1/2W	J : ±5%	NB : Non-burning type
RW : Winding	3A : 1W	K : ±10%	FR : Fuse-resistor
RN : Metal film	3D : 2W	M : ±20%	F : Lead wire forming
RK : Metal mixture	3F : 3W		
	3H : 5W		

* Resistance

$\overline{1} \overline{8} \overline{2} \Rightarrow 1800 \text{ ohm} = 1.8 \text{ kohm}$
 Indicates number of zeros after effective number.
 2-digit effective number.

• Units: ohm

$\overline{1} \overline{R} \overline{2} \Rightarrow 1.2 \text{ ohm}$
 1-digit effective number.
 2-digit effective number, decimal point indicated by R.

• Units: ohm

● Capacitors

Ex: CE 04W 1H 2R2 M BP
 Type Shape and performance Dielectric strength Capacity Allowable error Others

CE : Aluminum foil electrolytic	0J : 6.3V	F : ±1%	HS : High stability type
CA : Aluminum solid electrolytic	1A : 10V	G : ±2%	BP : Non-polar type
CS : Tantalum electrolytic	1C : 16V	J : ±5%	HR : Ripple-resistant type
CQ : Film	1E : 25V	K : ±10%	DL : For change and discharge
CK : Ceramic	1V : 35V	M : ±20%	HF : For assuring high frequency
CC : Ceramic	1H : 50V	Z : +80%	U : UL part
CP : Oil	2A : 100V	-20%	C : CSA part
CM : Mica	2B : 125V	P : +100%	W : UL-CSA type
CF : Metallized	2C : 160V	-0%	F : Lead wire forming
CH : Metallized	2D : 200V	C : ±0.25pF	
	2E : 250V	D : ±0.5pF	
	2H : 500V	= : Others	
	2J : 630V		

* Capacity (electrolyte only)

$\overline{2} \overline{2} \overline{2} \Rightarrow 2200\mu\text{F}$
 Indicates number of zeros after effective number.
 2-digit effective number.

• Units: μF .

$\overline{2} \overline{R} \overline{2} \Rightarrow 2.2\mu\text{F}$
 1-digit effective number.
 2-digit effective number, decimal point indicated by R.

• Units: μF .

* Capacity (except electrolyte)

$\overline{2} \overline{2} \overline{2} \Rightarrow 2200\text{pF} = 0.0022\mu\text{F}$
 (More than 2) — Indicates number of zeros after effective number.
 2-digit effective number.

• Units: μF .

$\overline{2} \overline{2} \overline{1} \Rightarrow 220\text{pF}$
 (0 or 1) — Indicates number of zeros after effective number.
 2-digit effective number.

• Units: pF.

• When the dielectric strength is indicated in AC, "AC" is included after the dielectric strength value.

PARTS LIST OF P.W.B. UNIT ASS'Y

1U-3346 (DCD-485Model) / 1U-3346A (DCD-685Model)

CD BOAD ASS'Y

Ref. No.	Part No.	Part Name	Remarks
SEMICONDUCTORS GROUP			
IC101	263 1091 907	IC LA6559	
IC102	262 2789 901	IC BU2616F(E2)	DCD-685 model only
IC103	263 1090 005	IC LA9241M	
IC104	262 1883 905	IC TC9246F-TP1	DCD-685 model only
IC106	262 2903 004	IC LC78625E	
IC107	262 1953 903	IC TC7WU04F	
IC301	262 2846 909	IC PCM1735E	DCD-485 model only
IC303	263 0615 902	IC BA15218F-DXE2	DCD-485 model only
IC304	262 1765 900	IC SM5841BS	DCD-685 model only
IC321,322	262 1837 032	IC PCM1702P-L	DCD-685 model only
IC323,324	263 0615 902	IC BA15218F-DXE2	DCD-685 model only
IC325	262 0864 006	IC UPC4570C	
IC502	263 0693 005	IC M5290P	
IC503	268 0074 904	IC ICP-N20T	
IC601	262 2904 003	IC UPD78044FGF-188-3B9	
IC602	499 0303 004	IC GP1UM271XK	
TR101-104	269 0054 901	Transistor DTC144EKT96	
TR105	271 0238 908	Transistor 2SA1037KT96(S/R)	
TR106	274 0120 002	Transistor 2SD1762(E/F)	
TR108,109	269 0085 909	Transistor DTC144TKT96	
TR323,324	274 0160 907	Transistor 2SD2144STPU	
TR401,402	274 0160 907	Transistor 2SD2144STPU	DCD-685 model only
TR403,404	273 0348 904	Transistor 2SC3326 A/B (TAPE)	DCD-485 model only
TR501	274 0120 002	Transistor 2SD1762(E/F)	
TR502	272 0083 004	Transistor 2SB1185(E/F)	
TR503	272 0025 907	Transistor 2SB562(C)TF	
TR504	269 0055 900	Transistor DTA144EKT96	
TR505	269 0082 902	Transistor DTC114EKT96	
TR506	269 0156 906	Transistor DTA124XKA-T146	
TR507	269 0082 902	Transistor DTC114EKT96	
D502-509	276 0704 903	Diode 1SR35-400A(T93X)	
D510	276 0432 903	Diode 1SS270A TE (TAPE)	
ZD101	276 0644 908	Zener diode MTZJ6.8A T77	
ZD102	276 0450 901	Zener diode HZS2B-1TD	DCD-685 model only
ZD501	276 0644 908	Zener diode MTZJ6.8A T77	
ZD502	276 0645 936	Zener diode MTZJ24A T77	
RESISTORS GROUP			
R101	247 2010 969	Carbon chip 22 kohm 1/10W	RM73B--223JT
R102-105	247 2009 941	Carbon chip 6.8 kohm 1/10W	RM73B--682JT
R106	247 2010 969	Carbon chip 22 kohm 1/10W	RM73B--223JT
R107	247 2018 903	Carbon chip 0 ohm 1/10W	RM73B--0R0KT
R108-110	247 2004 920	Carbon chip 47 ohm 1/10W	RM73B--470JT
R111	247 2010 969	Carbon chip 22 kohm 1/10W	RM73B--223JT
R112	247 2004 920	Carbon chip 47 ohm 1/10W	RM73B--470JT
R113	247 2012 925	Carbon chip 100 kohm 1/10W	RM73B--104JT
R114	247 2010 956	Carbon chip 20 kohm 1/10W	RM73B--203JT
R115	247 2009 909	Carbon chip 4.7 kohm 1/10W	RM73B--472JT (1608)
R116	247 2008 926	Carbon chip 2.2 kohm 1/10W	RM73B--222JT
R117	247 2004 920	Carbon chip 47 ohm 1/10W	RM73B--470JT
R118	247 2011 984	Carbon chip 68 kohm 1/10W	RM73B--683JT
R119	247 2010 914	Carbon chip 13 kohm 1/10W	RM73B--133JT
R120	247 2010 956	Carbon chip 20 kohm 1/10W	RM73B--203JT
R121	247 2009 909	Carbon chip 4.7 kohm 1/10W	RM73B--472JT (1608)
R122	247 2009 983	Carbon chip 10 kohm 1/10W	RM73B--103JT
R123	244 2050 920	Metal oxide 120 ohm 1W(NB)	RS14B3A121JNBST(S)
R124,125	247 2009 983	Carbon chip 10 kohm 1/10W	RM73B--103JT
R126-128	247 2018 903	Carbon chip 0 ohm 1/106W	DCD-685 model only RM73B--0R0KT
R129	247 2010 927	Carbon chip 15 kohm 1/10W	RM73B--153JT
R130	247 2006 986	Carbon chip 560 ohm 1/10W	RM73B--561JT
R131	247 2018 903	Carbon chip 0 ohm 1/10W	DCD-685 model only RM73B--0R0KT
R132	247 2010 927	Carbon chip 15 kohm 1/10W	RM73B--153JT
R133	247 2006 999	Carbon chip 620 ohm 1/10W	RM73B--621JT
R134	247 2010 969	Carbon chip 22 kohm 1/10W	RM73B--223JT
R135	247 2011 900	Carbon chip 33 kohm 1/10W	RM73B--333JT
R136-138	247 2010 969	Carbon chip 22 kohm 1/10W	RM73B--223JT
R139	247 2013 908	Carbon chip 220 kohm 1/10W	RM73B--224JT
R140	247 2009 983	Carbon chip 10 kohm 1/10W	RM73B--103JT
R141,142	247 2010 969	Carbon chip 22 kohm 1/10W	RM73B--223JT
R143	247 2006 986	Carbon chip 560 ohm 1/10W	RM73B--561JT
R144	247 2012 909	Carbon chip 82 kohm 1/10W	RM73B--823JT
R145	247 2011 900	Carbon chip 33 kohm 1/10W	RM73B--333JT
R146,147	247 2018 903	Carbon chip 0 ohm 1/10W	DCD-685 model only RM73B--0R0KT
R148	247 2011 926	Carbon chip 39 kohm 1/10W	RM73B--393JT
R150	247 2007 985	Carbon chip 1.5 kohm 1/10W	RM73B--152JT
R151	247 2010 927	Carbon chip 15 kohm 1/10W	RM73B--153JT
R152	247 2010 972	Carbon chip 24 kohm 1/10W	RM73B--243JT
R153	247 2010 927	Carbon chip 15 kohm 1/10W	RM73B--153JT
R154	247 2011 942	Carbon chip 47 kohm 1/10W	RM73B--473JT
R155	247 2018 903	Carbon chip 0 ohm 1/10W	DCD-685 model only RM73B--0R0KT
R156	247 2009 967	Carbon chip 8.2 kohm 1/10W	RM73B--822JT
R158	247 2009 967	Carbon chip 8.2 kohm 1/10W	RM73B--822JT
R159	247 2018 903	Carbon chip 0 ohm 1/10W	DCD-685 model only RM73B--0R0KT
R160	247 2011 926	Carbon chip 39 kohm 1/10W	RM73B--393JT
R161	247 2010 901	Carbon chip 12 kohm 1/10W	RM73B--123JT
R162	247 2010 927	Carbon chip 15 kohm 1/10W	RM73B--153JT
R163	247 2009 925	Carbon chip 5.6 kohm 1/10W	DCD-685 model only RM73B--562JT
R164	247 2002 964	Carbon chip 10 ohm 1/10W	RM73B--100JT
R165	247 2018 903	Carbon chip 0 ohm 1/10W	DCD-685 model only RM73B--0R0KT
R166	247 2011 942	Carbon chip 47 kohm 1/10W	RM73B--473JT
R167	247 2018 903	Carbon chip 0 ohm 1/10W	DCD-685 model only RM73B--0R0KT
R168	247 2009 941	Carbon chip 6.8 kohm 1/10W	RM73B--682JT
R169	247 2011 900	Carbon chip 33 kohm 1/10W	RM73B--333JT
R170	247 2018 903	Carbon chip 0 ohm 1/10W	DCD-685 model only RM73B--0R0KT
R171,172	247 2009 983	Carbon chip 10 kohm 1/10W	DCD-685 model only RM73B--103JT
R173	247 2008 926	Carbon chip 2.2 kohm 1/10W	RM73B--222JT
R174	247 2010 985	Carbon chip 27 kohm 1/10W	RM73B--273JT
R175	247 2012 912	Carbon chip 91 kohm 1/10W	RM73B--913JT
R176	247 2010 998	Carbon chip 30 kohm 1/10W	RM73B--303JT
R177	247 2006 931	Carbon chip 360 ohm 1/10W	RM73B--361JT
R178	247 2011 913	Carbon chip 36 kohm 1/10W	RM73B--363JT
R179	247 2012 954	Carbon chip 130 kohm 1/10W	RM73B--134JT
R180,181	247 2018 903	Carbon chip 0 ohm 1/10W	DCD-685 model only RM73B--0R0KT

Ref. No.	Part No.	Part Name	Remarks
R182	247 2005 903	Carbon chip 100 ohm 1/10W	RM73B--101JT DCD-685 model only
R183	247 2011 942	Carbon chip 47 kohm 1/10W	RM73B--473JT
R184-186	247 2018 903	Carbon chip 0 ohm 1/10W	RM73B--0R0KT
R187	247 2013 937	Carbon chip 300 kohm 1/10W	RM73B--304JT DCD-685 model only
R188	247 2018 903	Carbon chip 0 ohm 1/10W	RM73B--0R0KT DCD-685 model only
R189	247 2011 926	Carbon chip 39 kohm 1/10W	RM73B--393JT
R190	247 2008 968	Carbon chip 3.3 kohm 1/10W	RM73B--332JT
R191	247 2012 983	Carbon chip 180 kohm 1/10W	RM73B--184JT DCD-685 model only
R192	247 2008 939	Carbon chip 2.4 kohm 1/10W	RM73B--242JT DCD-685 model only
R193	247 2009 912	Carbon chip 5.1 kohm 1/10W	RM73B--512JT DCD-685 model only
R194	247 2009 909	Carbon chip 4.7 kohm 1/10W	RM73B--472JT (1608)
R195	247 2012 925	Carbon chip 100 kohm 1/10W	RM73B--104JT
R196,197	247 2013 924	Carbon chip 270 kohm 1/10W	RM73B--274JT
R198	247 2011 955	Carbon chip 51 kohm 1/10W	RM73B--513JT
R200	247 2009 983	Carbon chip 10 kohm 1/10W	RM73B--103JT
R201	247 2011 900	Carbon chip 33 kohm 1/10W	RM73B--333JT
R202	247 2010 969	Carbon chip 22 kohm 1/10W	RM73B--223JT
R204	247 2009 983	Carbon chip 10 kohm 1/10W	RM73B--103JT
R205	247 2018 903	Carbon chip 0 ohm 1/10W	RM73B--0R0KT DCD-685 model only
R206	247 2004 920	Carbon chip 47 ohm 1/10W	RM73B--470JT DCD-685 model only
R207	247 2015 906	Carbon chip 1.5 Mohm 1/10W	RM73B--155KT
R209	247 2006 902	Carbon chip 330 ohm 1/10W	RM73B--331JT (1608)
R210	247 2011 900	Carbon chip 33 kohm 1/10W	RM73B--333JT
R211	247 2007 901	Carbon chip 680 ohm 1/10W	RM73B--681JT
R212	247 2011 900	Carbon chip 33 kohm 1/10W	RM73B--333JT
R213	247 2007 969	Carbon chip 1.2 kohm 1/10W	RM73B--122JT
R214-217	247 2018 903	Carbon chip 0 ohm 1/10W	RM73B--0R0KT DCD-685 model only
R218	247 2007 943	Carbon chip 1 kohm 1/10W	RM73B--102JT DCD-685 model only
R220	247 2018 903	Carbon chip 0 ohm 1/10W	RM73B--0R0KT DCD-685 model only
R222	247 2003 947	Carbon chip 22 ohm 1/10W	RM73B--220JT DCD-685 model only
R223,224	247 2018 903	Carbon chip 0 ohm 1/10W	RM73B--0R0KT DCD-685 model only
R225,226	247 2003 947	Carbon chip 22 ohm 1/10W	RM73B--220JT
R227	247 2005 903	Carbon chip 100 ohm 1/10W	RM73B--101JT DCD-485 model only
R227	247 2006 902	Carbon chip 330 ohm 1/10W	RM73B--331JT DCD-685 model only
R228-230	247 2003 947	Carbon chip 22 ohm 1/10W	RM73B--220JT
R231	247 2011 942	Carbon chip 47 kohm 1/10W	RM73B--473JT
R232	247 2006 960	Carbon chip 470 ohm 1/10W	RM73B--471JT
R233	247 2004 920	Carbon chip 47 ohm 1/10W	RM73B--470JT
R234-237	247 2009 967	Carbon chip 8.2 kohm 1/10W	RM73B--822JT
R238	247 2005 903	Carbon chip 100 ohm 1/10W	RM73B--101JT
R240	247 2011 942	Carbon chip 47 kohm 1/10W	RM73B--473JT
R246-248	247 2009 983	Carbon chip 10 kohm 1/10W	RM73B--103JT
R250	247 2018 903	Carbon chip 0 ohm 1/10W	RM73B--0R0KT
R251	247 2018 903	Carbon chip 0 ohm 1/10W	RM73B--0R0KT DCD-685 model only
R252	247 2009 983	Carbon chip 10 kohm 1/10W	RM73B--103JT
R303,304	247 2011 942	Carbon chip 47 kohm 1/10W	RM73B--473JT DCD-485 model only
R305,306	247 2008 971	Carbon chip 3.6 kohm 1/10W	RM73B--362JT DCD-485 model only

Ref. No.	Part No.	Part Name	Remarks
R307,308	247 2011 942	Carbon chip 47 kohm 1/10W	RM73B--473JT DCD-485 model only
R309,310	247 2008 971	Carbon chip 3.6 kohm 1/10W	RM73B--362JT DCD-485 model only
R311-314	247 2009 983	Carbon chip 10 kohm 1/10W	RM73B--103JT DCD-485 model only
R315-318	247 2003 947	Carbon chip 22 ohm 1/10W	RM73B--220JT DCD-685 model only
R321,322	247 2008 939	Carbon chip 2.4 kohm 1/10W	RM73B--242JT DCD-685 model only
R323,324	247 2009 996	Carbon chip 11 kohm 1/10W	RM73B--113JT DCD-685 model only
R325,326	247 2009 925	Carbon chip 5.6 kohm 1/10W	RM73B--562JT DCD-685 model only
R327,328	247 2009 996	Carbon chip 11 kohm 1/10W	RM73B--113JT DCD-685 model only
R329,330	247 2010 998	Carbon chip 30 kohm 1/10W	RM73B--303JT
R339,340	247 2007 943	Carbon chip 1 kohm 1/10W	RM73B--102JT
R371,372	247 2010 998	Carbon chip 30 kohm 1/10W	RM73B--303JT
R373,374	247 2008 997	Carbon chip 4.3 kohm 1/10W	RM73B--432JT
R375,376	247 2008 984	Carbon chip 3.9 kohm 1/10W	RM73B--392JT
R377,378	247 2010 927	Carbon chip 15 kohm 1/10W	RM73B--153JT
R379,380	241 2377 934	Carbon film 91 ohm 1/4W(NB)	RD14B2E910JNBST
R401,402	247 2018 903	Carbon chip 0 ohm 1/10W	RM73B--0R0KT DCD-685 model only
R405,406	247 2008 942	Carbon chip 2.7 kohm 1/10W	RM73B--272JT DCD-685 model only
R409,410	247 2007 943	Carbon chip 1 kohm 1/10W	RM73B--102JT DCD-485 model only
R411	247 2018 903	Carbon chip 0 ohm 1/10W	RM73B--0R0KT
R502,503	241 2377 947	Carbon film 100 ohm 1/4W(NB)	RD14B2E101JNBST
R510	247 2009 983	Carbon chip 10 kohm 1/10W	RM73B--103JT
R511	247 2012 996	Carbon chip 200 kohm 1/10W	RM73B--204JT
R512	244 2051 974	Metal oxide 1 kohm 1W(NB)	
RS14B3A102JNBST(S)			
R513	241 2377 934	Carbon film 91 ohm 1/4W(NB)	RD14B2E910JNBST
R601,602	247 2009 983	Carbon chip 10 kohm 1/10W	RM73B--103JT
R603-608	247 2012 925	Carbon chip 100 kohm 1/10W	RM73B--104JT
R609,610	247 2007 943	Carbon chip 1 kohm 1/10W	RM73B--102JT
R611-616	247 2012 925	Carbon chip 100 kohm 1/10W	RM73B--104JT
R617	247 2014 965	Carbon chip 1 Mohm 1/10W	RM73B--105JT
R618-623	247 2012 925	Carbon chip 100 kohm 1/10W	RM73B--104JT
R624	247 2018 903	Carbon chip 0 ohm 1/10W	RM73B--0R0KT DCD-485 model only
R625	247 2009 983	Carbon chip 10 kohm 1/10W	RM73B--103JT DCD-685 model only
R626	247 2009 912	Carbon chip 5.1 kohm 1/10W	RM73B--512JT
R627,628	247 2009 983	Carbon chip 10 kohm 1/10W	RM73B--103JT
R629	247 2009 912	Carbon chip 5.1 kohm 1/10W	RM73B--512JT
R630-633	247 2012 925	Carbon chip 100 kohm 1/10W	RM73B--104JT
R634,635	247 2009 983	Carbon chip 10 kohm 1/10W	RM73B--103JT
R636,637	247 2007 943	Carbon chip 1 kohm 1/10W	RM73B--102JT
R638,639	247 2005 945	Carbon chip 150 ohm 1/10W	RM73B--151JT
R640	247 2009 983	Carbon chip 10 kohm 1/10W	RM73B--103JT
R641,642	247 2005 961	Carbon chip 180 ohm 1/10W	RM73B--181JT
R643,644	247 2006 915	Carbon chip 270 ohm 1/10W	RM73B--271JT
R645,646	247 2006 944	Carbon chip 390 ohm 1/10W	RM73B--391JT
R647,648	247 2009 983	Carbon chip 10 kohm 1/10W	RM73B--103JT
R649,650	247 2007 901	Carbon chip 680 ohm 1/10W	RM73B--681JT
R651	247 2007 972	Carbon chip 1.3 kohm 1/10W	RM73B--132JT
R652	247 2007 972	Carbon chip 1.3 kohm 1/10W	RM73B--132JT DCD-685 model only
R653,654	247 2009 983	Carbon chip 10 kohm 1/10W	RM73B--103JT
R655	247 2008 984	Carbon chip 3.9 kohm 1/10W	RM73B--392JT

Ref. No.	Part No.	Part Name	Remarks
R656	247 2008 984	Carbon chip 3.9 kohm 1/10W	RM73B--392JT DCD-685 model only
R657	247 2018 903	Carbon chip 0 ohm 1/10W	RM73B--0R0KT
VR401	211 0903 008	Variable resistor 2 kohm	V1420Q15FC202 DCD-685 model only
CAPACITORS GROUP			
C101-107	257 0512 903	Ceramic chip 0.1uF/25V	CK73F1E104ZT
C108	254 4538 942	Electrolytic 100uF/16V	CE04W1C101MT SMG/RE3
C109	257 0516 925	Ceramic chip 0.033uF/25V	CK73B1E333KT
C110	257 0507 976	Ceramic chip 330pF/50V	CC73CH1H331JT
C111,112	257 0512 903	Ceramic chip 0.1uF/25V	CK73F1E104ZT
C113	254 4524 927	Electrolytic 0.33uF/50V	CE04W1HR33MT SMG/RE3
C114	257 0501 927	Ceramic chip 0.015uF/50V	CK73B1H153KT
C115	257 0501 901	Ceramic chip 0.01uF/50V	CK73B1H103KT (1608)
C116	257 0517 908	Ceramic chip 0.047uF/16V	CK73B1C473KT
C117,118	257 0504 982	Ceramic chip 47pF/50V	CC73CH1H470JT DCD-685 model only
C119	257 0509 929	Ceramic chip 1000pF/50V	CK73B1H102KT
C120	257 0506 993	Ceramic chip 150pF/50V	CC73CH1H151JT
C121	257 0512 903	Ceramic chip 0.1uF/25V	CK73F1E104ZT
C122	257 0517 908	Ceramic chip 0.047uF/16V	CK73B1C473KT
C123	257 0501 901	Ceramic chip 0.01uF/50V	CK73B1H103KT (1608)
C124,125	257 0517 908	Ceramic chip 0.047uF/16V	CK73B1C473KT
C127	257 0512 903	Ceramic chip 0.1uF/25V	CK73F1E104ZT
C130	257 0512 903	Ceramic chip 0.1uF/25V	CK73F1E104ZT
C131	257 0501 901	Ceramic chip 0.01uF/50V	CK73B1H103KT (1608) DCD-685 model only
C132	257 0512 903	Ceramic chip 0.1uF/25V	CK73F1E104ZT DCD-685 model only
C133	254 4538 968	Electrolytic 330uF/16V	CE04W1C331MT SMG/RE3 DCD-685 model only
C136	254 4524 969	Electrolytic 3.3uF/50V	CE04W1H3R3MT SMG/RE3
C137,138	257 0501 901	Ceramic chip 0.01uF/50V	CK73B1H103KT (1608)
C139	257 0509 929	Ceramic chip 1000pF/50V	CK73B1H102KT
C140	257 0512 903	Ceramic chip 0.1uF/25V	CK73F1E104ZT
C141	254 4538 939	Electrolytic 47uF/16V	CE04W1C470MT SMG/RE3
C142	257 0509 929	Ceramic chip 1000pF/50V	CK73B1H102KT
C143	257 0507 992	Ceramic chip 390pF/50V	CC73CH1H391JT DCD-685 model only
C144	257 0512 903	Ceramic chip 0.1uF/25V	CK73F1E104ZT
C145	257 0507 934	Ceramic chip 220pF/50V	CC73CH1H221JT
C146	257 0509 929	Ceramic chip 1000pF/50V	CK73B1H102KT
C147	254 4538 955	Electrolytic 220uF/16V	CE04W1C221MT SMG/RE3
C148	257 0514 901	Ceramic chip 0.33uF/16V	CK73F1C334ZT
C149	257 0501 901	Ceramic chip 0.01uF/50V	CK73B1H103KT (1608)
C150	247 2018 903	Carbon chip 0 ohm 1/16W	RM73B--0R0KT DCD-685 model only
C151,152	247 2018 903	Carbon chip 0 ohm 1/16W	RM73B--0R0KT
C153	257 0512 903	Ceramic chip 0.1uF/25V	CK73F1E104ZT
C154	257 0517 908	Ceramic chip 0.047uF/16V	CK73B1C473KT
C155	257 0501 901	Ceramic chip 0.01uF/50V	CK73B1H103KT (1608)
C156	254 4538 942	Electrolytic 100uF/16V	CE04W1C101MT SMG/RE3
C157	257 0501 901	Ceramic chip 0.01uF/50V	CK73B1H103KT (1608)
C158	257 0512 903	Ceramic chip 0.1uF/25V	CK73F1E104ZT
C159	257 0510 918	Ceramic chip 3300pF/50V	CK73B1H332KT
C160	254 3056 917	Electrolytic 1uF/50V	CE04D1H010MBPT (SME)
C162	257 0506 951	Ceramic chip 100pF/50V	CC73CH1H101JT DCD-685 model only
C163	254 4538 900	Electrolytic 10uF/16V	CE04W1C100MT SMG/RE3
C164	257 0512 903	Ceramic chip 0.1uF/25V	CK73F1E104ZT
C165	257 0506 951	Ceramic chip 100pF/50V	CC73CH1H101JT
C166,167	257 0512 903	Ceramic chip 0.1uF/25V	CK73F1E104ZT
C168	254 4538 942	Electrolytic 100uF/16V	CE04W1C101MT SMG/RE3

Ref. No.	Part No.	Part Name	Remarks
C170	254 4538 942	Electrolytic 100uF/16V	CE04W1C101MT SMG/RE3
C171	254 4278 901	Electrolytic 0.68uF/50V	CE04W1HR68MT (SME) DCD-685 model only
C173	254 3056 917	Electrolytic 1uF/50V	CE04D1H010MBPT (SME)
C174	257 0510 918	Ceramic chip 3300pF/50V	CK73B1H332KT
C175,176	247 2018 903	Carbon chip 0 ohm 1/16W	RM73B--0R0KT
C177	254 4538 939	Electrolytic 47uF/16V	CE04W1C470MT SMG/RE3
C178	254 4538 942	Electrolytic 100uF/16V	CE04W1C101MT SMG/RE3 DCD-685 model only
C179	257 0512 903	Ceramic chip 0.1uF/25V	CK73F1E104ZT DCD-685 model only
C180	247 2018 903	Carbon chip 0 ohm 1/16W	RM73B--0R0KT DCD-685 model only
C181	254 4538 900	Electrolytic 10uF/16V	CE04W1C100MT SMG/RE3
C182	257 0512 903	Ceramic chip 0.1uF/25V	CK73F1E104ZT DCD-685 model only
C184	257 0512 903	Ceramic chip 0.1uF/25V	CK73F1E104ZT
C185	247 2018 903	Carbon chip 0 ohm 1/16W	RM73B--0R0KT DCD-685 model only
C186	257 0509 929	Ceramic chip 1000pF/50V	CK73B1H102KT
C189	257 0503 941	Ceramic chip 12pF/50V	CC73CH1H120JT
C190	257 0501 901	Ceramic chip 0.01uF/50V	CK73B1H103KT (1608) DCD-685 model only
C191	254 4538 968	Electrolytic 330uF/16V	CE04W1C331MT SMG/RE3 DCD-685 model only
C192	257 0512 903	Ceramic chip 0.1uF/25V	CK73F1E104ZT DCD-685 model only
C194	257 0501 901	Ceramic chip 0.01uF/50V	CK73B1H103KT (1608)
C195	254 4524 972	Electrolytic 4.7uF/50V	CE04W1H4R7MT SMG/RE3
C196	254 4538 942	Electrolytic 100uF/16V	CE04W1C101MT SMG/RE3 DCD-685 model only
C197	257 0509 929	Ceramic chip 1000pF/50V	CK73B1H102KT DCD-685 model only
C198	257 0501 901	Ceramic chip 0.01uF/50V	CK73B1H103KT (1608) DCD-685 model only
C199	257 0517 908	Ceramic chip 0.047uF/16V	CK73B1C473KT
C201,202	257 0512 903	Ceramic chip 0.1uF/25V	CK73F1E104ZT
C203	254 4538 942	Electrolytic 100uF/16V	CE04W1C101MT SMG/RE3
C204	257 0506 951	Ceramic chip 100pF/50V	CC73CH1H101JT
C207	254 4538 942	Electrolytic 100uF/16V	CE04W1C101MT SMG/RE3
C208,209	257 0512 903	Ceramic chip 0.1uF/25V	CK73F1E104ZT
C211	257 0512 903	Ceramic chip 0.1uF/25V	CK73F1E104ZT
C212	257 0501 901	Ceramic chip 0.01uF/50V	CK73B1H103KT (1608)
C213	257 0509 929	Ceramic chip 1000pF/50V	CK73B1H102KT
C214,215	257 0503 941	Ceramic chip 12pF/50V	CC73CH1H120JT DCD-485 model only
C216	257 0512 903	Ceramic chip 0.1uF/25V	CK73F1E104ZT DCD-685 model only
C217	254 4538 968	Electrolytic 330uF/16V	CE04W1C331MT SMG/RE3 DCD-685 model only
C218	257 0501 901	Ceramic chip 0.01uF/50V	CK73B1H103KT (1608) DCD-685 model only
C219	257 0512 903	Ceramic chip 0.1uF/25V	CK73F1E104ZT
C220	257 0511 917	Ceramic chip 0.022uF/50V	CK73F1H223ZT
C221	254 4538 942	Electrolytic 100uF/16V	CE04W1C101MT SMG/RE3
C222	257 0512 903	Ceramic chip 0.1uF/25V	CK73F1E104ZT
C223,224	257 0507 989	Ceramic chip 360pF/50V	CC73CH1H361JT
C225	257 0512 903	Ceramic chip 0.1uF/25V	CK73F1E104ZT
C226	257 0509 929	Ceramic chip 1000pF/50V	CK73B1H102KT
C227	257 0512 903	Ceramic chip 0.1uF/25V	CK73F1E104ZT
C228	254 4538 942	Electrolytic 100uF/16V	CE04W1C101MT SMG/RE3
C229	257 0504 940	Ceramic chip 33pF/50V	CC73CH1H330JT
C230,231	257 0512 903	Ceramic chip 0.1uF/25V	CK73F1E104ZT
C232	257 0501 901	Ceramic chip 0.01uF/50V	CK73B1H103KT (1608)
C233	247 2018 903	Carbon chip 0 ohm 1/16W	RM73B--0R0KT DCD-685 model only
C234	257 0506 951	Ceramic chip 100pF/50V	CC73CH1H101JT

Ref. No.	Part No.	Part Name	Remarks
C236-239	257 0506 951	Ceramic chip 100pF/50V	CC73CH1H101JT
C249	254 4538 942	Electrolytic 100uF/16V	CE04W1C101MT SMG/RE3
C252	254 4538 942	Electrolytic 100uF/16V	CE04W1C101MT SMG/RE3
C253,254	257 0501 901	Ceramic chip 0.01uF/50V	CK73B1H103KT (1608)
C255	254 4538 942	Electrolytic 100uF/16V	CE04W1C101MT SMG/RE3
C256	254 4538 955	Electrolytic 220uF/16V	CE04W1C221MT SMG/RE3
C257	257 0512 903	Ceramic chip 0.1uF/25V	CK73F1E104ZT
C258	257 0507 934	Ceramic chip 220pF/50V	CC73CH1H221JT
C301	254 4538 939	Electrolytic 47uF/16V	CE04W1C470MT SMG/RE3 DCD-485 model only
C302,303	257 0512 903	Ceramic chip 0.1uF/25V	CK73F1E104ZT DCD-485 model only
C304	254 4538 942	Electrolytic 100uF/16V	CE04W1C101MT SMG/RE3 DCD-485 model only
C305,306	254 4538 900	Electrolytic 10uF/16V	CE04W1C100MT SMG/RE3 DCD-485 model only
C307,308	257 0512 903	Ceramic chip 0.1uF/25V	CK73F1E104ZT DCD-485 model only
C309	254 4538 939	Electrolytic 47uF/16V	CE04W1C470MT SMG/RE3 DCD-485 model only
C310,311	257 0512 903	Ceramic chip 0.1uF/25V	CK73F1E104ZT DCD-485 model only
C312,313	254 4538 900	Electrolytic 10uF/16V	CE04W1C100MT SMG/RE3 DCD-485 model only
C314	257 0512 903	Ceramic chip 0.1uF/25V	CK73F1E104ZT DCD-485 model only
C315,316	254 4524 956	Electrolytic 2.2uF/50V	CE04W1H2R2MT SMG/RE3 DCD-485 model only
C317,318	255 4232 937	Mylar film 1000pF/100V	CQ93P2A102JT(NH) DCD-485 model only
C321,322	255 4232 908	Mylar film 820pF/100V	CQ93P2A821JT(NH) DCD-485 model only
C325	257 0512 903	Ceramic chip 0.1uF/25V	CK73F1E104ZT DCD-685 model only
C326	254 4538 939	Electrolytic 47uF/16V	CE04W1C470MT SMG/RE3 DCD-685 model only
C327-330	257 0512 903	Ceramic chip 0.1uF/25V	CK73F1E104ZT DCD-685 model only
C331-334	254 4538 939	Electrolytic 47uF/16V	CE04W1C470MT SMG/RE3 DCD-685 model only
C335-340	257 0512 903	Ceramic chip 0.1uF/25V	CK73F1E104ZT DCD-685 model only
C341,342	257 0501 901	Ceramic chip 0.01uF/50V	CK73B1H103KT (1608) DCD-685 model only
C343,344	254 4538 913	Electrolytic 22uF/16V	CE04W1C220MT SMG/RE3 DCD-685 model only
C345,346	254 4538 939	Electrolytic 47uF/16V	CE04W1C470MT SMG/RE3 DCD-685 model only
C347-350	257 0512 903	Ceramic chip 0.1uF/25V	CK73F1E104ZT DCD-685 model only
C351,352	254 4538 942	Electrolytic 100uF/16V	CE04W1C101MT SMG/RE3 DCD-685 model only
C353-356	254 4538 939	Electrolytic 47uF/16V	CE04W1C470MT SMG/RE3 DCD-685 model only
C357-362	257 0512 903	Ceramic chip 0.1uF/25V	CK73F1E104ZT DCD-685 model only
C363,364	257 0507 950	Ceramic chip 270pF/50V	CC73CH1H271JT DCD-685 model only
C365,366	257 0506 951	Ceramic chip 100pF/50V	CC73CH1H101JT DCD-685 model only
C367,368	257 0509 929	Ceramic chip 1000pF/50V	CK73B1H102KT DCD-685 model only
C371,372	257 0512 903	Ceramic chip 0.1uF/25V	CK73F1E104ZT DCD-685 model only
C373,374	254 4538 900	Electrolytic 10uF/16V	CE04W1C100MT SMG/RE3 DCD-685 model only

Ref. No.	Part No.	Part Name	Remarks
C375,376	257 0507 934	Ceramic chip 220pF/50V	CC73CH1H221JT DCD-685 model only
C377,378	257 0512 903	Ceramic chip 0.1uF/25V	CK73F1E104ZT DCD-685 model only
C379,380	254 4538 900	Electrolytic 10uF/16V	CE04W1C100MT SMG/RE3 DCD-685 model only
C381,382	254 4538 939	Electrolytic 47uF/16V	CE04W1C470MT SMG/RE3
C383,384	257 0509 929	Ceramic chip 1000pF/50V	CK73B1H102KT
C385,386	257 0505 907	Ceramic chip 56pF/50V	CC73CH1H560JT
C387,388	254 4538 942	Electrolytic 100uF/16V	CE04W1C101MT SMG/RE3
C389	257 0512 903	Ceramic chip 0.1uF/25V	CK73F1E104ZT
C390	254 4538 942	Electrolytic 100uF/16V	CE04W1C101MT SMG/RE3
C391	257 0512 903	Ceramic chip 0.1uF/25V	CK73F1E104ZT
C392	254 4538 942	Electrolytic 100uF/16V	CE04W1C101MT SMG/RE3
C393	257 0512 903	Ceramic chip 0.1uF/25V	CK73F1E104ZT DCD-685 model only
C394	257 0512 903	Ceramic chip 0.1uF/25V	CK73F1E104ZT DCD-485 model only
C395,396	257 0506 951	Ceramic chip 100pF/50V	CC73CH1H101JT
C397	257 0512 903	Ceramic chip 0.1uF/25V	CK73F1E104ZT
C398	257 0501 901	Ceramic chip 0.01uF/50V	CK73B1H103KT (1608)
C401,402	257 0501 901	Ceramic chip 0.01uF/50V	CK73B1H103KT (1608)
C403	257 0512 903	Ceramic chip 0.1uF/25V	CK73F1E104ZT
C404-406	257 0501 901	Ceramic chip 0.01uF/50V	CK73B1H103KT (1608)
C407	257 0512 903	Ceramic chip 0.1uF/25V	CK73F1E104ZT
C408	257 0501 901	Ceramic chip 0.01uF/50V	CK73B1H103KT (1608)
C409	257 0512 903	Ceramic chip 0.1uF/25V	CK73F1E104ZT
C410	257 0501 901	Ceramic chip 0.01uF/50V	CK73B1H103KT (1608)
C411	257 0512 903	Ceramic chip 0.1uF/25V	CK73F1E104ZT
C412	257 0501 901	Ceramic chip 0.01uF/50V	CK73B1H103KT (1608)
C413	257 0512 903	Ceramic chip 0.1uF/25V	CK73F1E104ZT
C504,505	254 4538 942	Electrolytic 100uF/16V	CE04W1C101MT SMG/RE3
C506	254 4524 943	Electrolytic 1uF/50V	CE04W1H010MT SMG/RE3
C507	254 4524 969	Electrolytic 3.3uF/50V	CE04W1H3R3MT SMG/RE3
C508,509	254 4525 926	Electrolytic 100uF/50V	CE04W1H101MT SMG/RE3
C510,511	254 4525 900	Electrolytic 33uF/50V	CE04W1H330MT SMG/RE3
C512	254 4403 721	Electrolytic 2200uF/25V	CE04W1E222MC (SMG)
C513	254 4403 734	Electrolytic 4700uF/25V	CE04W1E472MC (SMG)
C515	253 1146 907	Ceramic chip 0.01uF/50V	CK45F1H103ZT
C520	257 0501 901	Ceramic chip 0.01uF/50V	CK73B1H103KT (1608)
C522,523	253 9030 950	Ceramic 6800pF/25V	CK45=1E682KT
C524	253 1146 907	Ceramic chip 0.01uF/50V	CK45F1H103ZT
C525	254 4524 943	Electrolytic 1uF/50V	CE04W1H010MT SMG/RE3
C526	254 4538 955	Electrolytic 220uF/16V	CE04W1C221MT SMG/RE3
C527	253 8022 707	Ceramic chip 0.01 uF/250V(AC)	CK45F2EAC103MC
C529-531	257 0512 903	Ceramic chip 0.1uF/25V	CK73F1E104ZT
C532	254 4541 955	Electrolytic 220uF/25V	CE04W1E221MT SMG/RE3
C533,534	257 0512 903	Ceramic chip 0.1uF/25V	CK73F1E104ZT
C536	254 4524 943	Electrolytic 1uF/50V	CE04W1H010MT SMG/RE3
C601-603	257 0512 903	Ceramic chip 0.1uF/25V	CK73F1E104ZT
C605	257 0512 903	Ceramic chip 0.1uF/25V	CK73F1E104ZT
C606,607	257 0506 951	Ceramic chip 100pF/50V	CC73CH1H101JT
C608	257 0512 903	Ceramic chip 0.1uF/25V	CK73F1E104ZT
C610	257 0506 951	Ceramic chip 100pF/50V	CC73CH1H101JT
C611,612	257 0501 901	Ceramic chip 0.01uF/50V	CK73B1H103KT (1608)
C613,614	257 0512 903	Ceramic chip 0.1uF/25V	CK73F1E104ZT
C615,616	257 0501 901	Ceramic chip 0.01uF/50V	CK73B1H103KT (1608)
C617	257 0512 903	Ceramic chip 0.1uF/25V	CK73F1E104ZT
C618	257 0506 951	Ceramic chip 100pF/50V	CC73CH1H101JT

Ref. No.	Part No.	Part Name	Remarks	Q'ty
OTHER PARTS GROUP				
CX21	203 2349 009	2P inlet		1
CX22	205 0581 001	2P VH connector base		1
CX41	205 0343 045	4P connector base (KR-PH)		1
CX51,52	205 0343 058	5P connector base (KR-PH)		2
CX53	205 0190 052	5P NH connector base		1
CX61	205 0343 061	6P connector base (KR-PH)		1
CX63	205 0190 065	6P NH connector base		1
CX141	204 6504 005	14P PH-SAN connector cord		1
CX161	205 0892 033	16P FFC base (P=1)		1
CX271	205 0880 016	27P FFC connector base		1
CY22	205 0581 001	2P VH connector base		1
CY41	205 0343 045	4P connector base (KR-PH)		1
CY52	205 0355 059	5P KR connector base (L)		1
CY141	205 0375 042	14P connector base (KR-PH)		1
CY271	205 0880 016	27P FFC connector base		1
FB101	247 2018 903	Carbon chip 0 ohm 1/16W	RM73B--0R0KT	1
FB102	247 2018 903	Carbon chip 0 ohm 1/16W	RM73B--0R0KT	2
			DCD-685 model only	
FB103,104	235 0129 901	Chip emifil		2
FB105	247 2018 903	Carbon chip 0 ohm 1/16W	RM73B--0R0KT	1
			DCD-685 model only	
FB107,108	235 0129 901	Chip emifil		2
FB109	247 2018 903	Carbon chip 0 ohm 1/16W	RM73B--0R0KT	1
FB110	247 2018 903	Carbon chip 0 ohm 1/16W	RM73B--0R0KT	2
			DCD-685 model only	
FB112-115	235 0129 901	Chip emifil		4
FB116	247 2018 903	Carbon chip 0 ohm 1/16W	RM73B--0R0KT	1
			DCD-685 model only	
FB118	247 2018 903	Carbon chip 0 ohm 1/16W	RM73B--0R0KT	1
			DCD-685 model only	
FB119,120	235 0129 901	Chip emifil		2
FB121	247 2018 903	Carbon chip 0 ohm 1/16W	RM73B--0R0KT	1
			DCD-685 model only	
FB123	247 2018 903	Carbon chip 0 ohm 1/16W	RM73B--0R0KT	1
			DCD-685 model only	
FB125	235 0129 901	Chip emifil		1
FB126,127	235 0049 900	Beads inductor		2
FL601	393 8021 006	VFD		1
JK101	269 0188 000	TOTX178		1
JK301	204 8537 009	2P pin jack (GNB) D		1
JK401	204 8264 071	Headphone jack (gold)		1
L501	239 8019 002	Line filter coil	DCD-485 model only	1
△S501	212 1030 009	Power switch (TV-5)		1
S601-610	212 5604 910	Tact switch		10
S611	212 0410 002	Rotary encoder-jog		1
S614	212 5604 910	Tact switch		1
S617	212 5604 910	Tact switch		1
S618-620	212 5604 910	Tact switch	DCD-685 model only	4
S619	212 5604 910	Tact switch	DCD-485 model only	1

Ref. No.	Part No.	Part Name	Remarks	Q'ty
ST1,2	205 0452 017	Style pin		2
ST501,502	205 0452 017	Style pin		2
TM501	412 9483 009	Earth plate		1
W701	203 0539 031	1P SIN cord Ass'y		1
X101	399 0743 005	Crystal 8.4672 MHz	DCD-685 model only	1
X103	399 0742 006	Crystal 16.9344 MHz	DCD-485 model only	1
X601	399 0755 909	Ceramic resonator4.23MHz	CSTS0423MG06-T2	1
	461 0862 045	FL spacer (T=5)	under FL601	2
	412 4809 002	IC Heat spreader		1
	417 0579 001	HEAT SINK	assembled with TR502	1

PARTS LIST OF EXPLODED VIEW

Ref.No.	Part No.	Part Name	Remarks	Q'ty	Ref.No.	Part No.	Part Name	Remarks	Q'ty
1	1U-3346	CD board ass'y	DCD-485 model only	1	SCREWS				
1	1U-3346A	CD board ass'y	DCD-685 model only	1					
1-1		Servo & D/A unit			40	473 7002 021	3X8 CBTS (S)-B	DCD-485 model only	22
1-2		Power unit						DCD-685 model only	20
1-3		Display unit			41	477 0064 107	Fixing screw		5
1-4		H/P jack unit			42	473 7004 016	4X6 CBTS (S)-Z		2
1-5		Power sw unit			43	473 7508 017	3X10 CBTS (P)-B	DCD-485 model only	11
2-1	146 2232 208	Front panel	DCD-485 model only	1				DCD-685 model only	7
2-2	-	H/P PWB holder	DCD-485 model only	1	44	473 8044 017	Special screw	DCD-485 model only	2
2	144 2758 003	Front panel	DCD-685 model only	1				DCD-685 model only	1
2	144 2758 016	Front panel	Gold model only(685)	1	45	473 8007 025	3X8 cup screw		3
3	143 1114 001	Window	DCD-485 model only	1	46	477 0263 005	3P. swelling screw		4
3	143 1066 117	Window	DCD-685 model only	1	46	477 0263 018	3P. swelling screw	Gold model only	4
4-1	146 2141 409	Inner panel	DCD-685 model only	1	47	473 7002 034	3X6 CBTS (S)-B		3
4-1	146 2141 412	Inner panel	Gold model only(685)	1					
4-2	-	H/P PWB holder	DCD-685 model only	1					
5	113 1849 029	Function knob		1					
5	113 1849 074	Function knob	Gold model only(685)	1					
6	113 1904 003	Tact knob(4P)	DCD-485 model only	1					
7	113 1850 005	Tact knob (6P)	Gold model only(685)	1					
7	113 1850 018	Tact knob (6P)	DCD-685 model only	1					
8	412 2814 044	Card spacer (L=6)	DCD-685 model only	1					
9	412 4782 006	Support bracket(F)	DCD-485 model only	1					
10	412 4783 005	Support bracket(B)	DCD-485 model only	1					
11	113 9213 000	P• knob (P) ass'y		1					
11	113 9213 084	P• knob (P) ass'y	Gold model only(685)	1					
12	112 0851 002	Knob (Maru)		1					
12	112 0851 015	Knob (Maru)	Gold model only(685)	1					
13	112 0811 013	Knob (Fuji)	DCD-685 model only	1					
13	112 0811 000	Knob (Fuji)	Gold model only(685)	1					
15	461 0501 005	Rubber sheet	DCD-685 model only	3					
20	411 1386 509	Chassis		1					
21	105 1318 245	Back panel	DCD-485 model only	1					
21	105 1318 258	Back panel	DCD-685 model only	1					
22	102 0604 003	Top cover		1					
22	102 0604 016	Top cover	Gold model only(685)	1					
23	104 0260 100	Foot ass'y		4					
24	412 4784 004	Semko bracket		1					
25	477 0308 009	Hole plug		1					
26	445 0124 008	Flat cable clamp		1					
27	337 0064 003	CD mech(KSL-2130CCM)		1					
28	146 2233 100	Loader panel		1					
28	146 2233 113	Loader panel	Gold model only(685)	1					
29	415 9016 035	P.C.B holder		2					
30	412 2814 015	Card spacer (L=14)		1					
31	417 0613 006	Heat sink(PH-0125-M)	AS101	1					
32	417 0579 001	Heat sink	AS102	1					
△ 33	233 6369 002	Power trans(E2/EK)		1					
50	204 6504 005	14P PH-SAN con cord	CX141	1					
51	204 0536 011	6P PH-PH con.cord		1					
52	203 8299 056	5P KR-KR con cord		1					
53	009 0159 013	16P FFC cable		1					
54	009 0133 039	27P FFC		1					
55	203 6514 018	4P PH-PH shield cord		1					
56	203 5132 051	3P VH-VH conn.cord		1					
57	203 8363 034	5P PH-PH conn cord		1					
★	513 2358 007	E2 laser caution		1					
★	513 1642 002	No. sheet		1					

EXPLODED VIEW

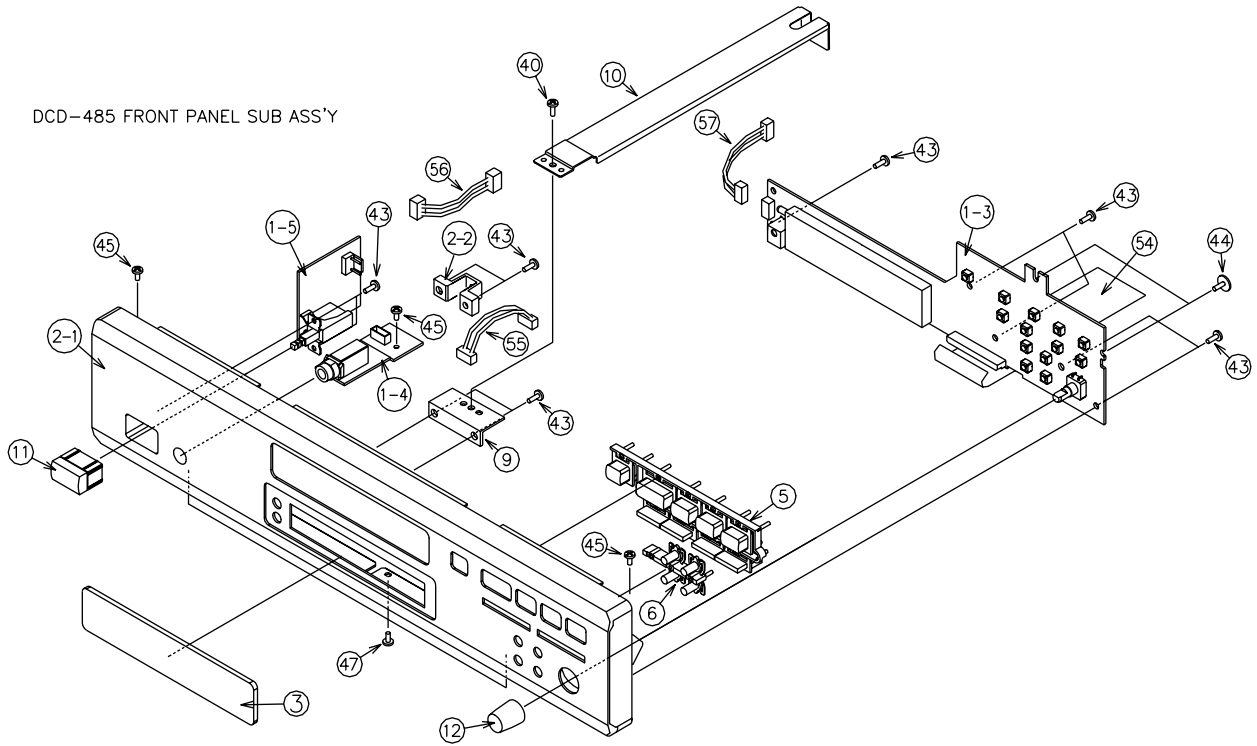

DCD-485 FRONT PANEL SUB ASS'Y

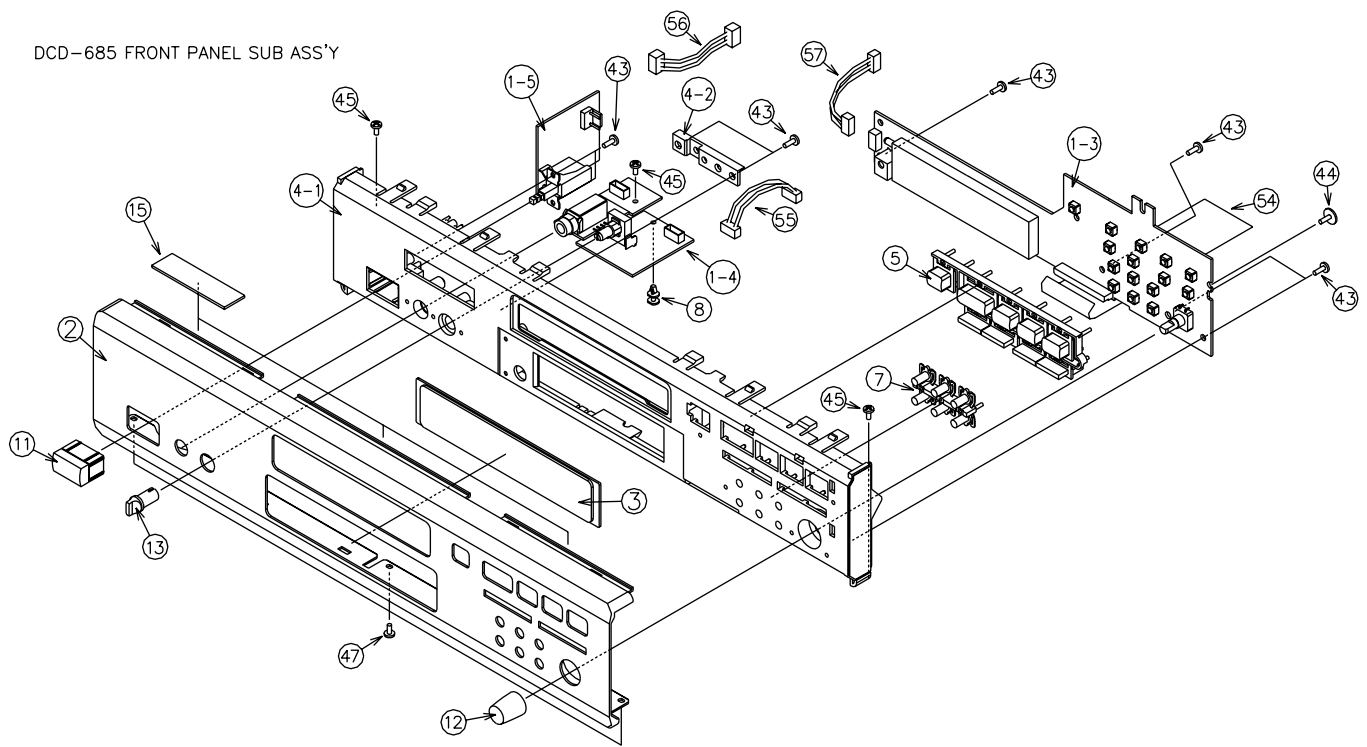

DCD-685 FRONT PANEL SUB ASS'Y

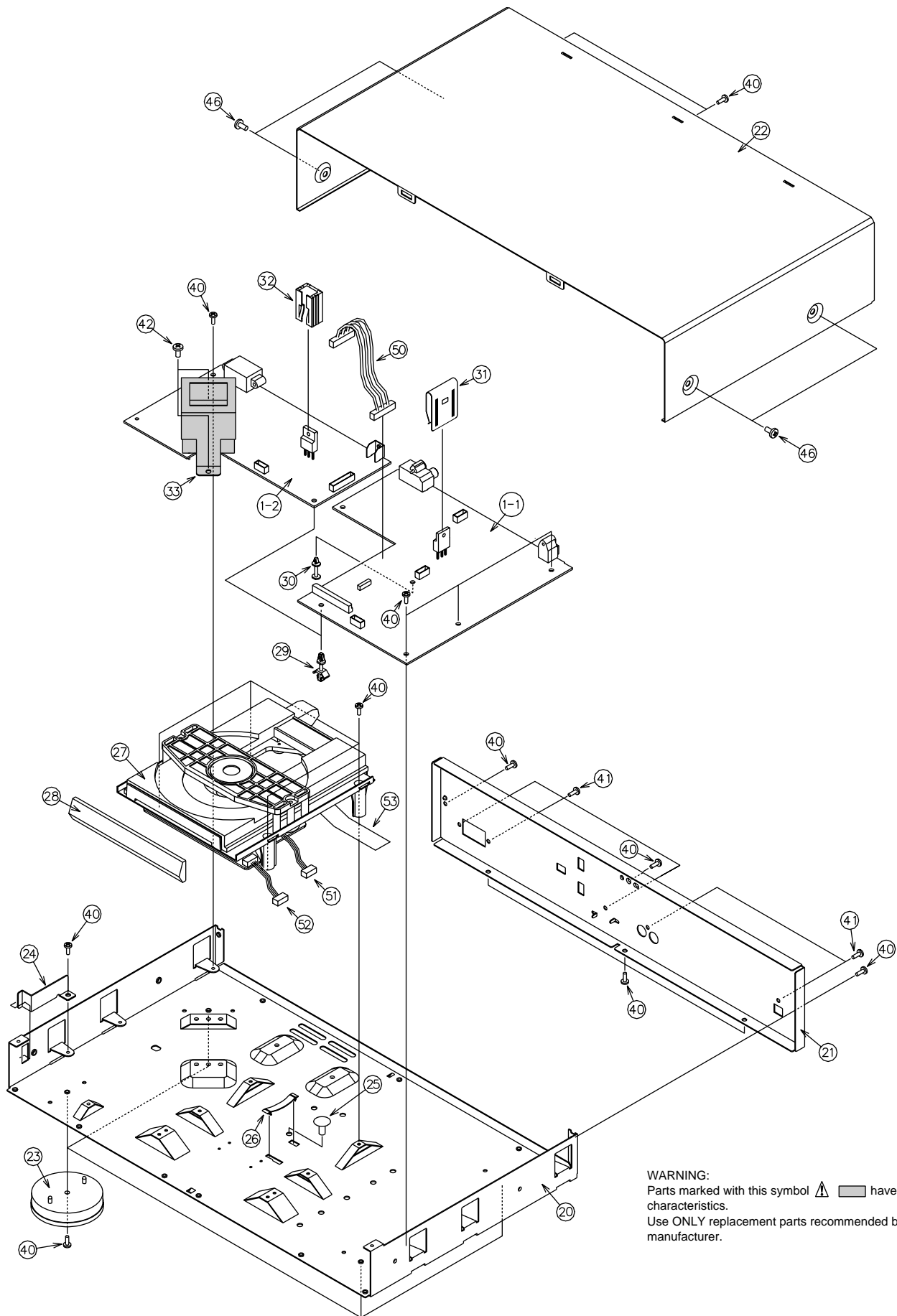



WARNING:
 Parts marked with this symbol   have critical characteristics.
 Use **ONLY** replacement parts recommended by the manufacturer.

PARTS LIST OF CD MECHANISM UNIT

Ref. No.	Part No.	Part Name	Remarks	Qty
1	S26 4629 001	Tray (C)		1
2		This part (No.2)doesn't belong to the tray. Take it down from old tray and use again when changing the tray.		
3	S26 2554 401	Gear cover(S)		1
4	S26 2553 501	Tray gear(S)		1
5	S26 2554 601	Chucking plate		1
6	S26 2629 401	Screw 2.6 x 7 +PTPWH		4
7	S26 2553 701	Chucking yoke		1
8	S14 5249 321	Magnet		1
9	S26 2554 102	Damper		1
10	S26 4629 101	Chucking pulley		1
11	S26 4628 801	Sub chassis Ass'y		1
12-1	S26 2723 601	Coil spring(front)		2
12-2	S26 2723 501	Coil spring(back)		2
13	-	Screw 2.6 x 10 +P	No slit type2	4
14	S26 4628 901	Washer 2130		4
17	S26 2555 206	Outsert main chassis(S)		1
18	S33 1950 151	Screw 2.6 x 16 +PTPWH		1
19	S26 2554 701	Drive gear(S)		1
20	S26 2554 504	Contorol cam(S)		1
21	S16 9266 711	Leaf switch		2
22	S15 6472 111	5P connector		1
23	S16 4052 311	Loading P.W.B		1
24	SX2 6251 171	Loading motor Ass'Y		1
25	S26 2553 402	Middle gear		1
26	S26 2553 602	Loading pulley		1
27	S36 5338 700	LM belt		1
28	S26 2527 901	Screw 2.6 x 2.5 +B		1
31	S26 2690 801	Sled shaft		1
32	S26 2723 401	Insulator		4
33	S26 4138 601	Tapping screw 2 x 5		4
34	S26 2562 501	Plate		1
35	S26 2519 101	Coil spring		1
36	S26 2547 701	Center ring		1
37	S88 4848 305	Laser pick up	KSS-213C	1
38	S26 2518 802	Gear(A)		1
39	SX2 6259 841	Motor chassis Ass'y		1
40	SX2 6257 691	Motor gear Ass'y		1
41	S16 3967 812	Motor P.W.B.		1
42	S15 7208 511	Leaf switch		1
43	S15 6472 211	6P connector		1
44	S76 2125 515	Screw 2 x 3 +P		1

EXPLODED VIEW OF CD MECHANISM UNIT KSL 2130 CCM

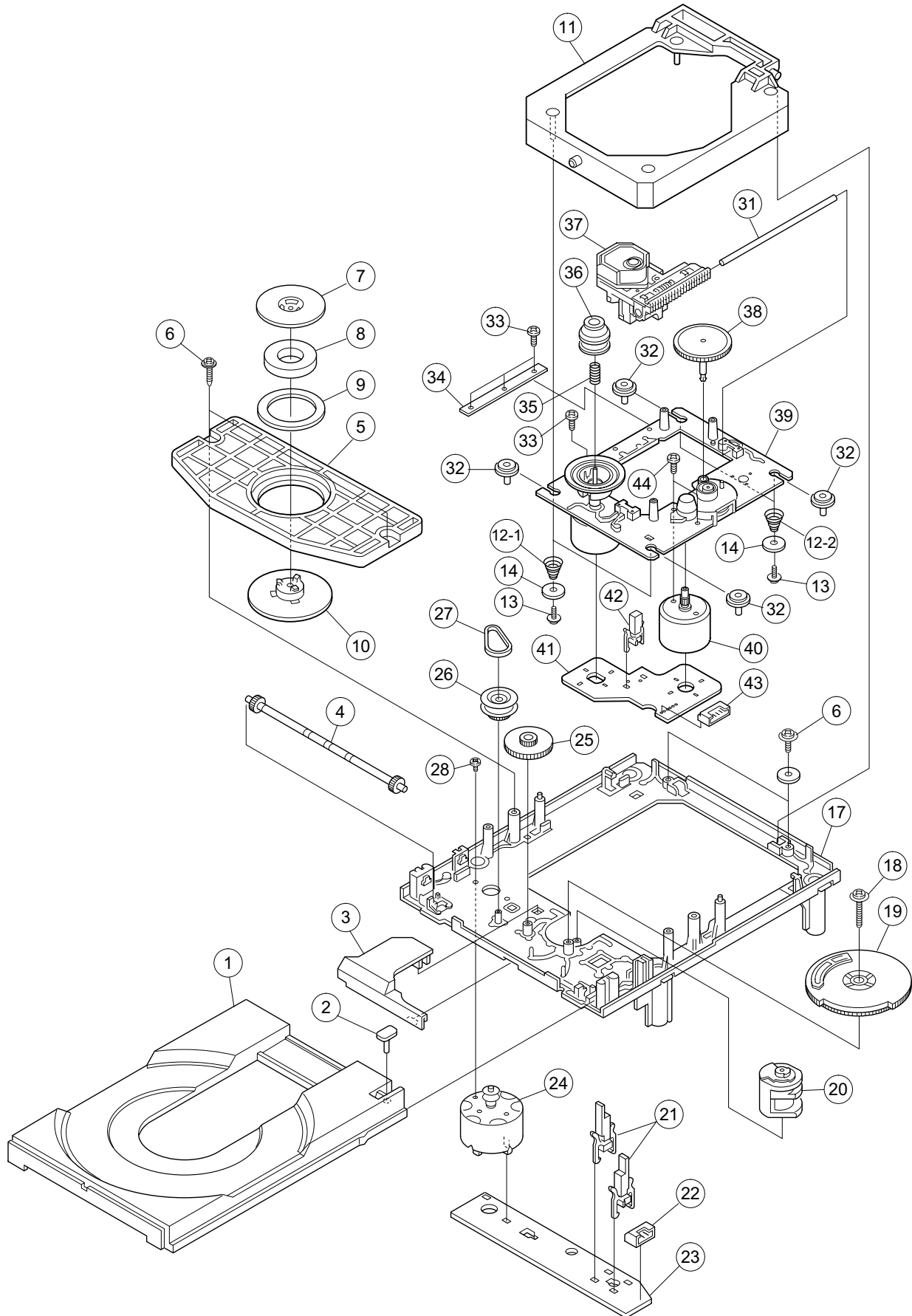

PACKING VIEW

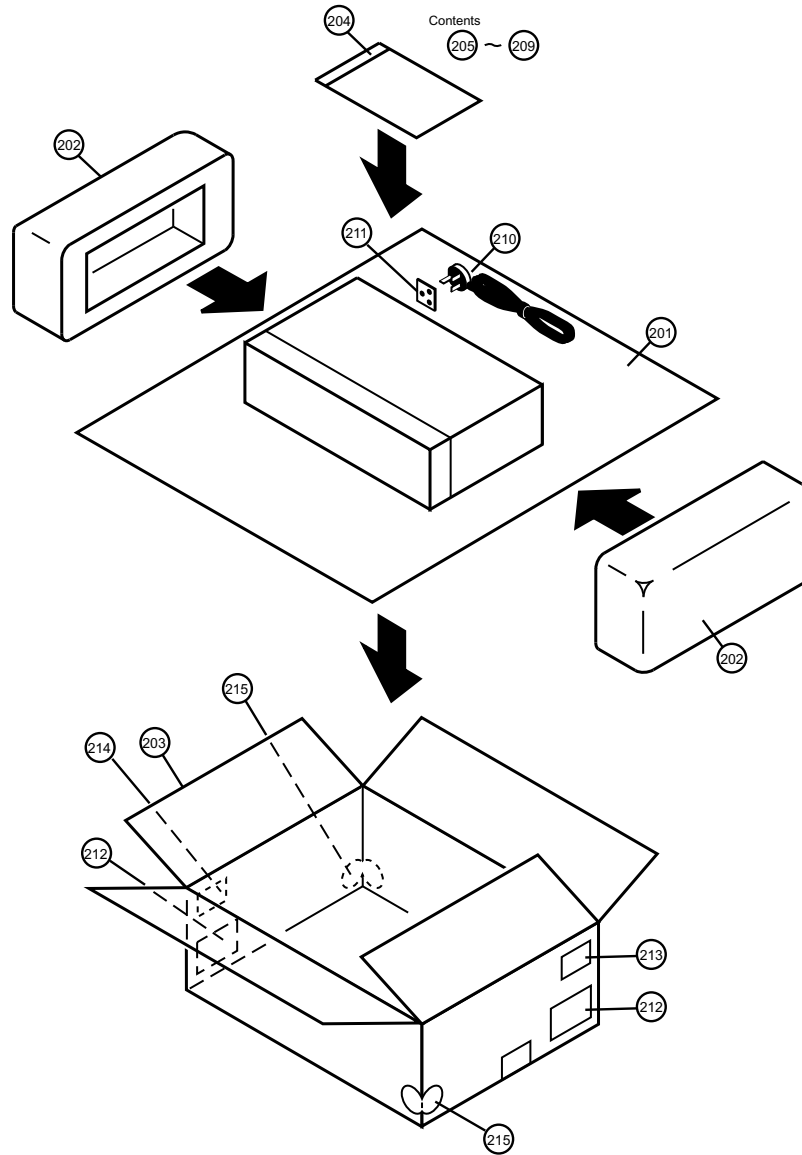

PARTS LIST OF PACKING AND ACCESSORIES

Ref.No.	Part No.	Part Name	Remarks	Q'ty
201	505 0131 050	Cabinet cover		1
202	503 1386 002	Cushion		2
203	501 2131 001	Carton case	DCD-485 model only	1
203	501 2131 014	Carton case	DCD-685 model only	1
204	505 9125 009	Poly cover		1
205	515 0867 101	S.S.list(EX)		1
206	203 2310 009	2P pin cord		1
207	399 0360 006	RC-266		1
208	206 2108 003	AC conn with plug	Europe model only	1
209	511 3758 008	Inst.manual		1
210	206 2113 001	AC cord w/con EK	U.K. model only	1
211	509 9120 006	Spacer carton	U.K. model only	1
212	-	Cont. card		1
213	-	Bar code label		1
214	-	Bar code label	U.K. model only	1
215	513 9111 001	Color label (Gold)	Gold model only	2

SCHEMATIC DIAGRAM (for DCD-485)

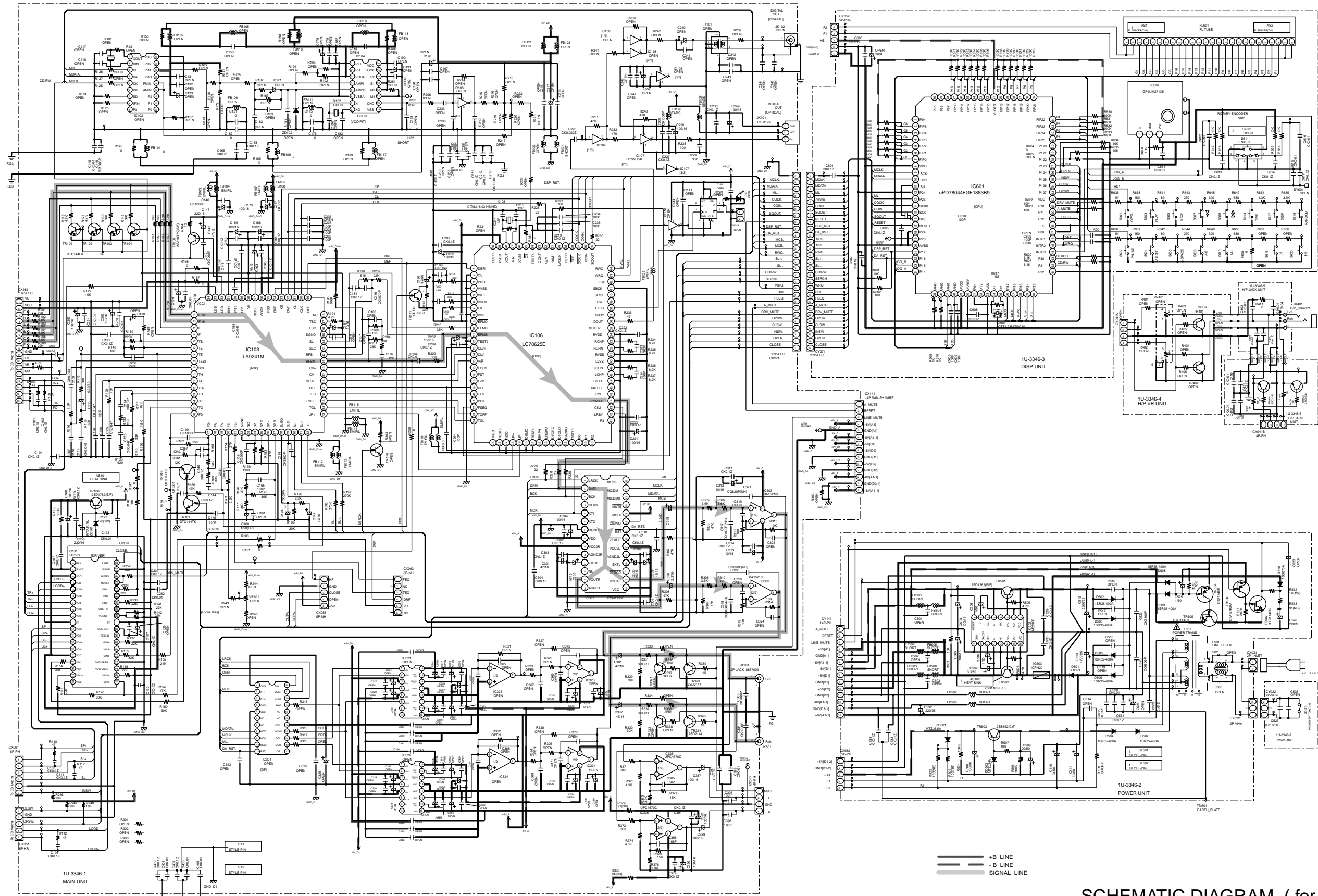

SCHEMATIC DIAGRAM (for DCD-485)
1U-3346

NOTICE
ALL RESISTANCE VALUES IN OHM, k=1,000 OHM M=1,000,000 OHM
ALL CAPACITANCE VALUES IN MICRO FARAD, p=MICRO-MICRO FARAD
EACH VOLTAGE AND CURRENT ARE MEASURED AT NO SIGNAL INPUT
CONDITION.
CIRCUIT AND PARTS ARE SUBJECT TO CHANGE WITHOUT PRIOR
NOTICE.

WARNING:
Parts marked with this symbol have critical characteristics.
Use ONLY replacement parts recommended by the manufacturer.

CAUTION:
Before returning the unit to the customer, make sure you make either (1) a leakage current check or (2) a line to chassis resistance check. If the leakage current exceeds 0.5 millamps, or if the resistance from chassis to either side of the power cord is less than 400 kohms, the unit is defective.

WARNING:
DO NOT return the unit to the customer until the problem is located and corrected.

SCHEMATIC DIAGRAM (for DCD-485)

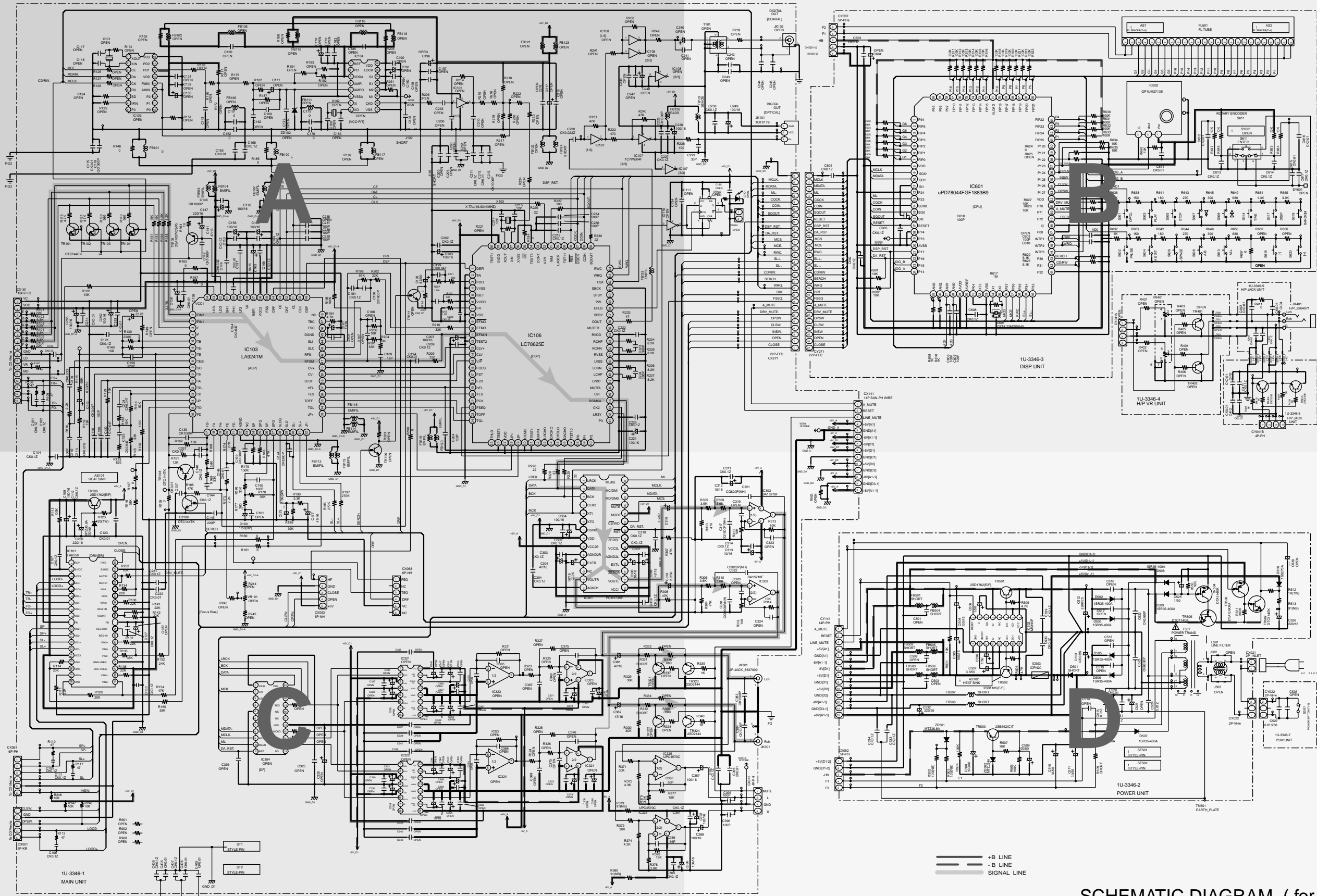

NOTICE
 ALL RESISTANCE VALUES IN OHM, k=1,000 OHM M=1,000,000 OHM
 ALL CAPACITANCE VALUES IN MICRO FARAD, p=MICRO-MICRO FARAD
 EACH VOLTAGE AND CURRENT ARE MEASURED AT NO SIGNAL INPUT
 CONDITION.
 CIRCUIT AND PARTS ARE SUBJECT TO CHANGE WITHOUT PRIOR
 NOTICE.

WARNING:
 Parts marked with this symbol have critical characteristics.
 Use ONLY replacement parts recommended by the manufacturer.
CAUTION:
 Before returning the unit to the customer, make sure you make either (1) a
 leakage current check or (2) a line to chassis resistance check. If the leakage
 current exceeds 0.5 millamps, or if the resistance from chassis to either side
 of the power card is less than 400 kohms, the unit is defective.
WARNING:
 DO NOT return the unit to the customer until the problem is located and
 corrected.

SCHEMATIC DIAGRAM (for DCD-485)
 1U-3346

SCHEMATIC DIAGRAM (for DCD-485)

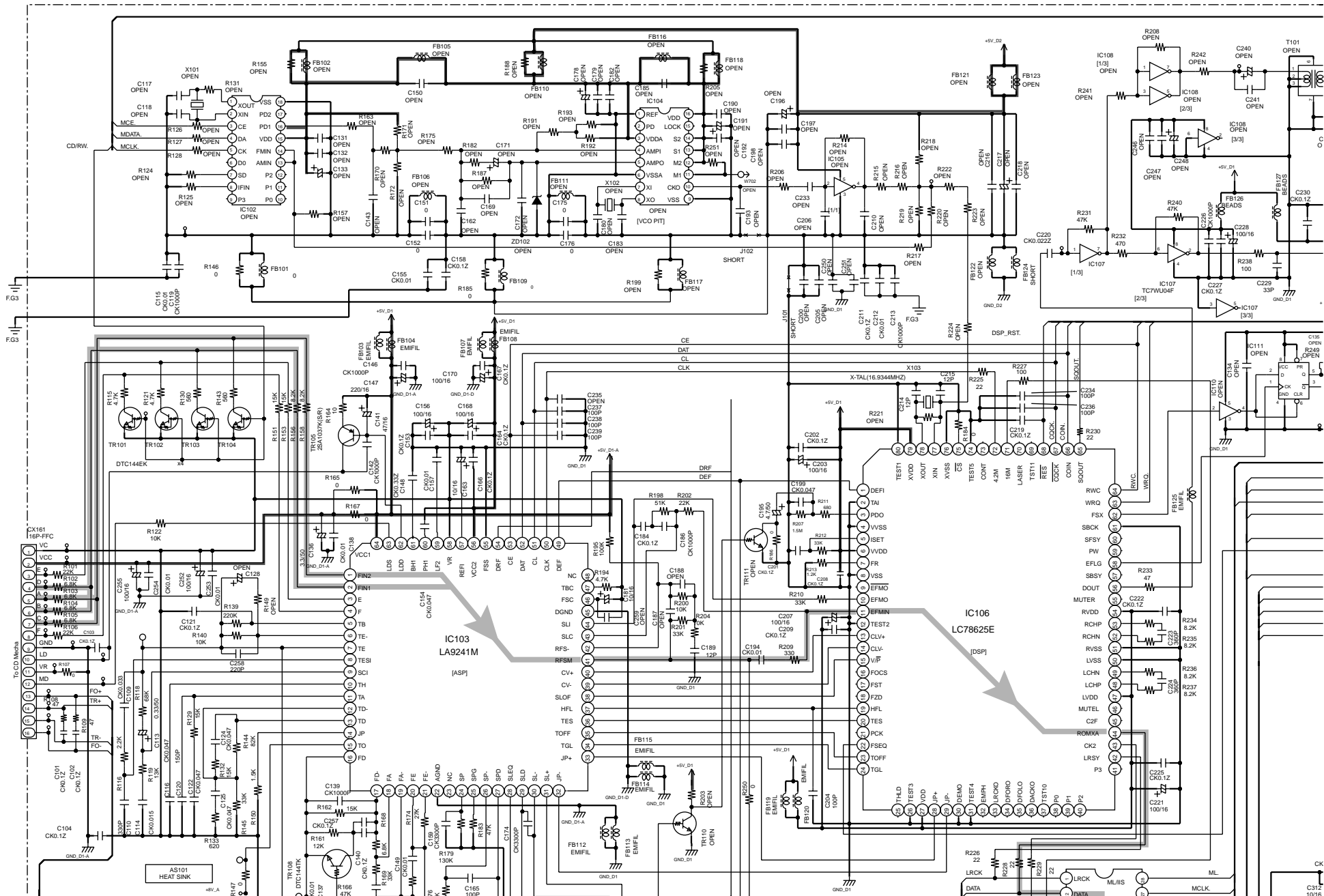

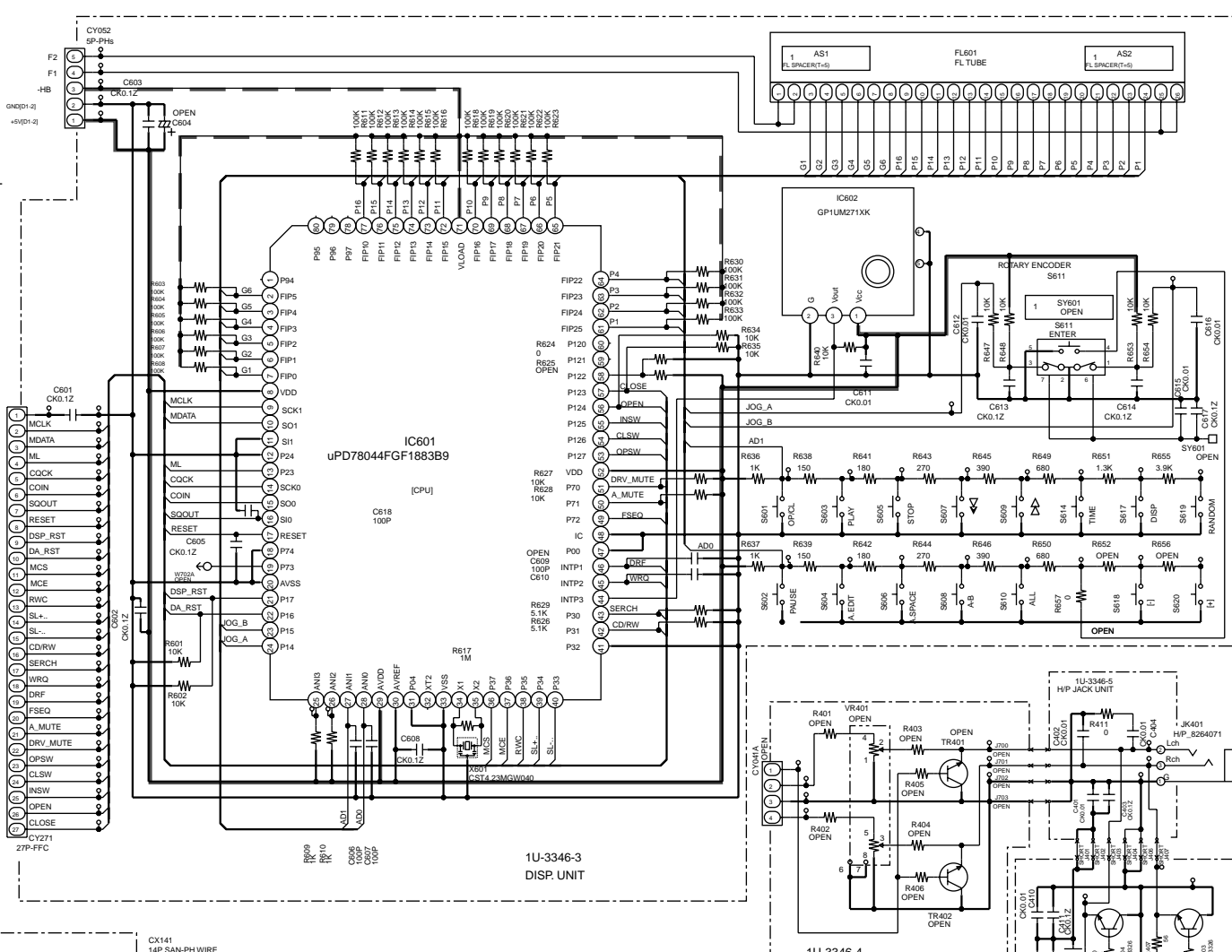
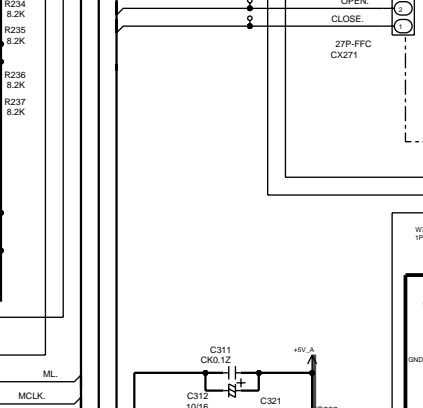
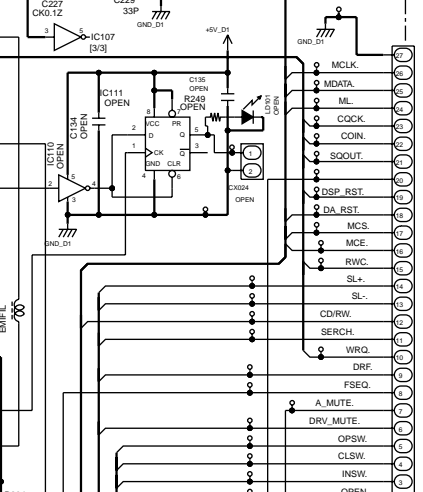
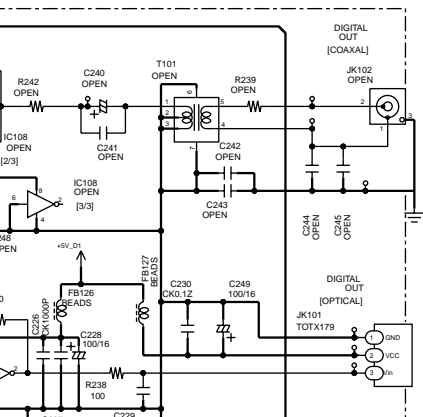

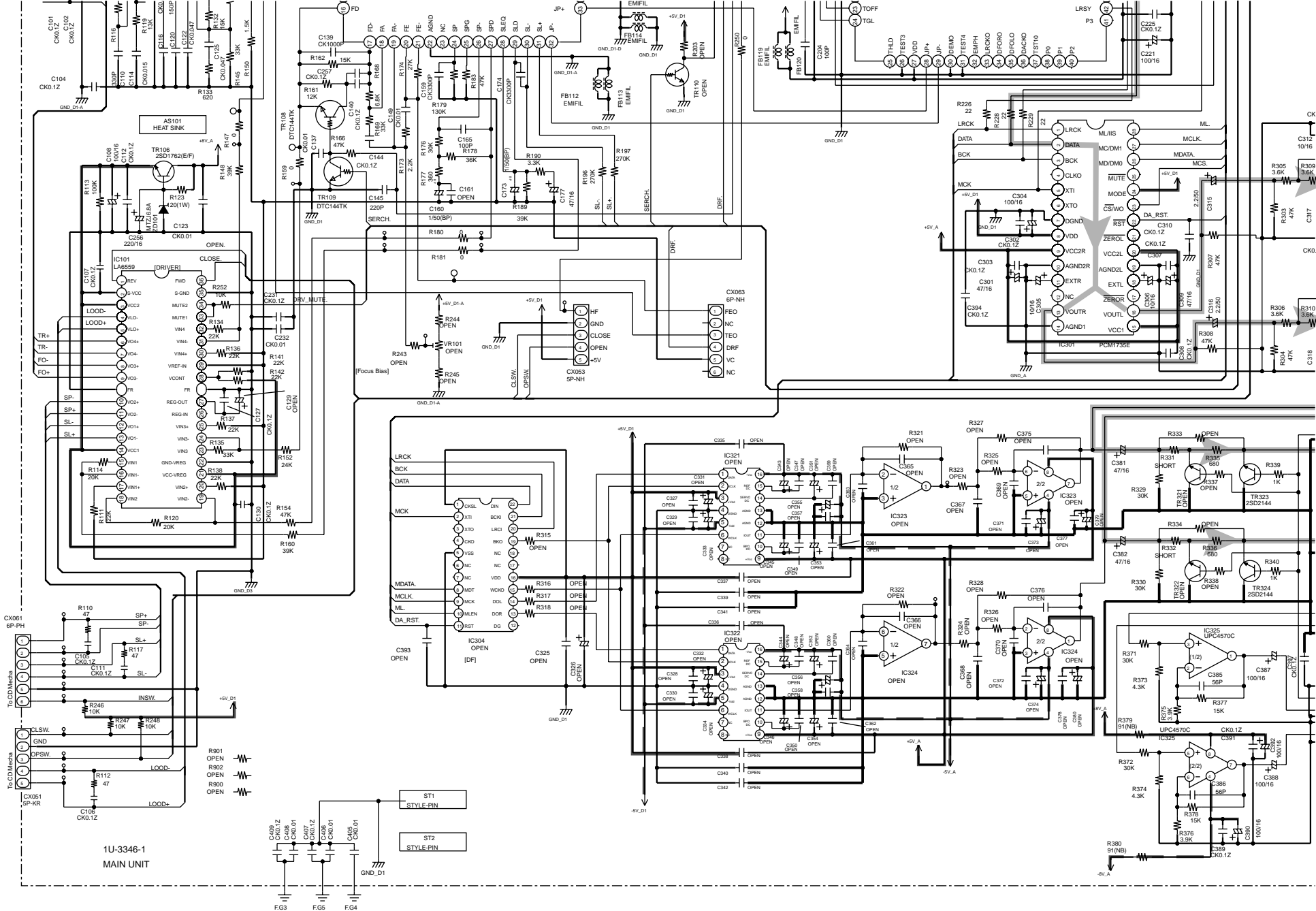

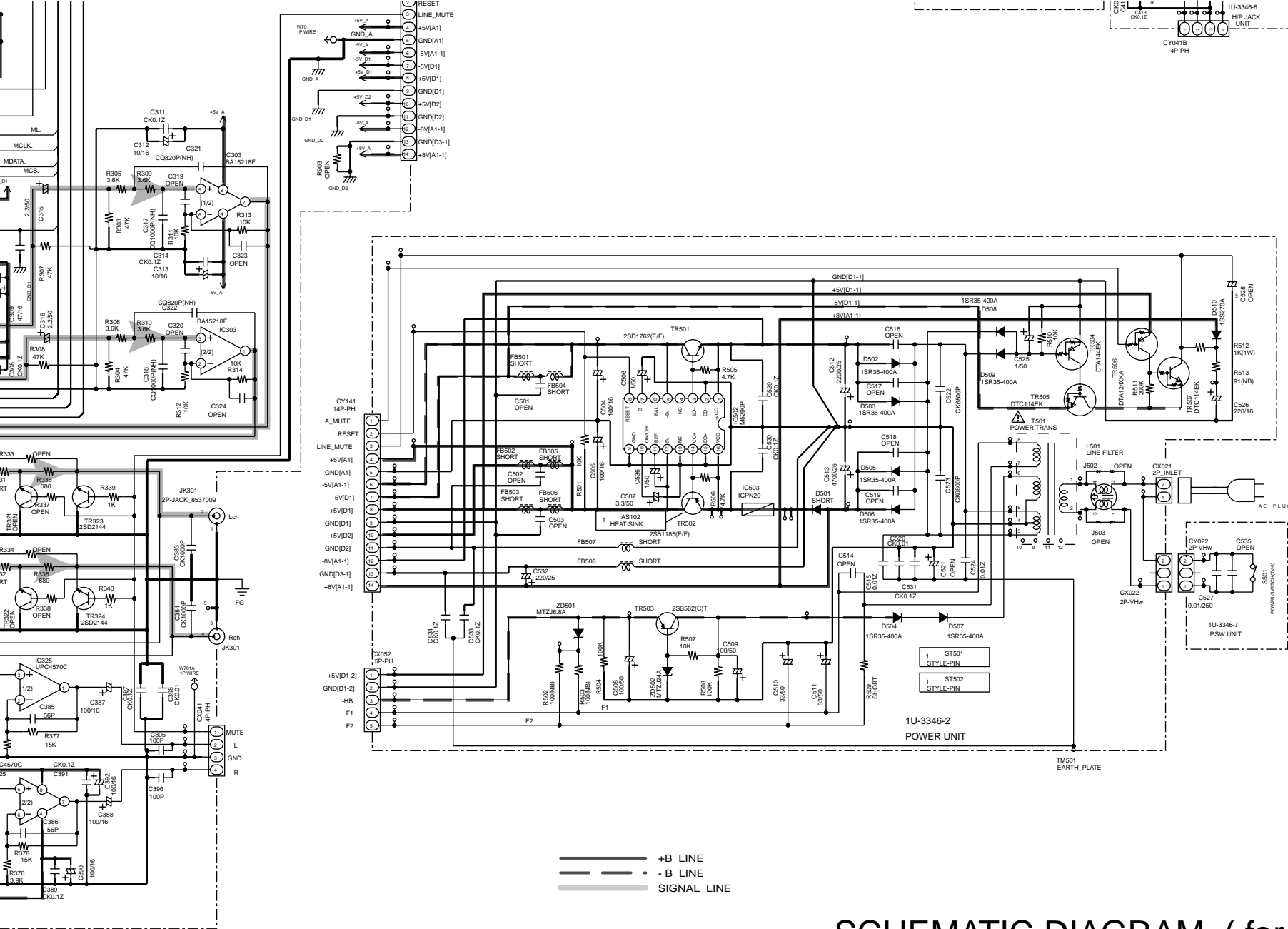

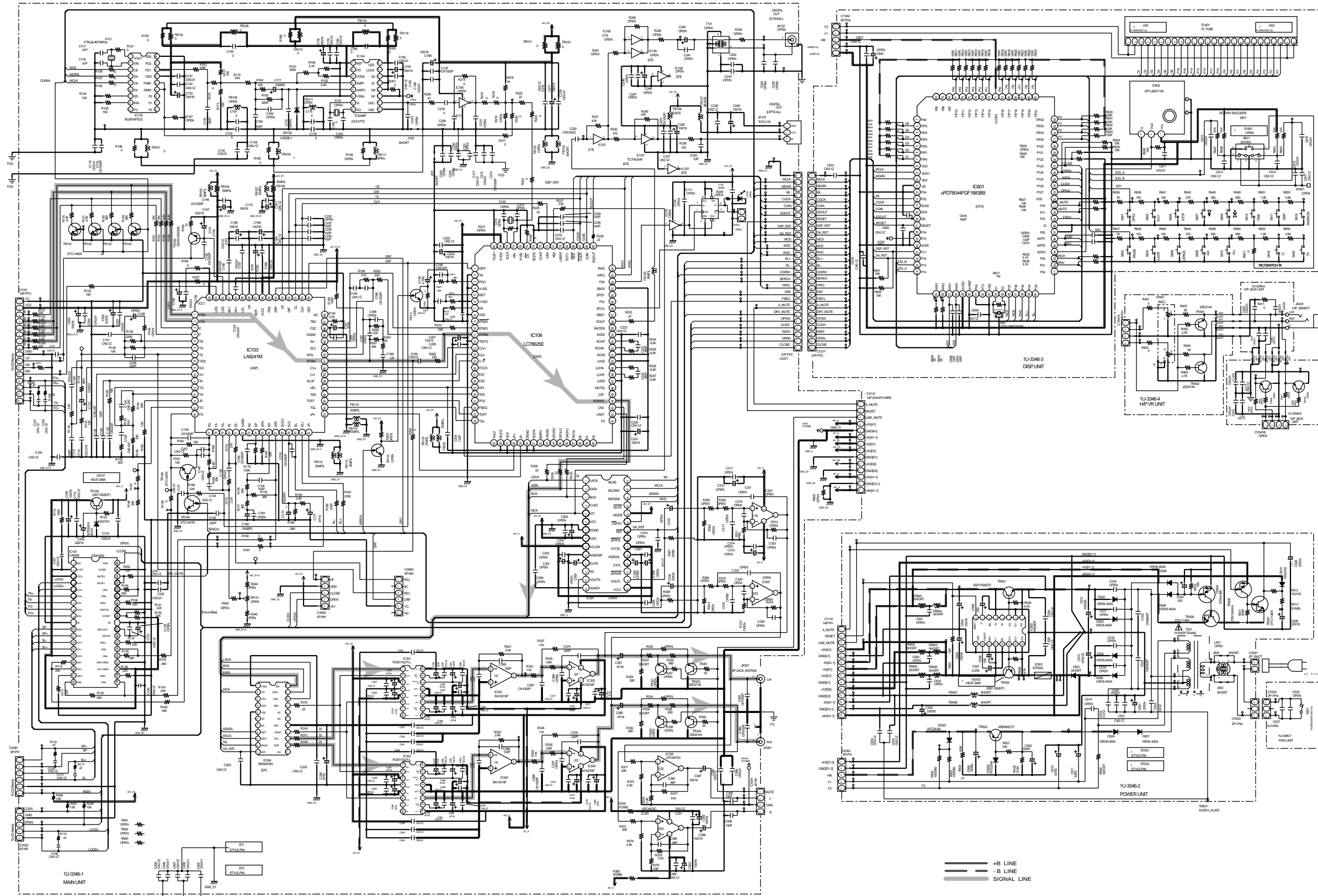

SCHEMATIC DIAGRAM (for DCD-485)
1U-3346

SCHEMATIC DIAGRAM (for DCD-685)



SCHEMATIC DIAGRAM (for DCD-685)
1U-3346A

NOTICE
ALL RESISTANCE VALUES IN OHM, k=1,000 OHM M=1,000,000 OHM
ALL CAPACITANCE VALUES IN MICRO-FARAD. P=MICRO MICRO-FARAD
EACH VOLTAGE AND CURRENT ARE MEASURED AT NO SIGNAL INPUT
CONDITION.
CIRCUITRY AND PARTS ARE SUBJECT TO CHANGE WITHOUT PRIOR
NOTICE.

WARNING:
Parts marked with this symbol  have critical characteristics.
Use ONLY replacement parts recommended by the manufacturer.
CAUTION:
Before returning the unit to the customer, make sure you make either (1) a
leakage current check or (2) a line to chassis resistance check. If the leakage
current exceeds 0.2 milliamperes, or if the resistance from chassis to either side
of the power cord is less than 400 kilohms, the unit is defective.
WARNING:
DO NOT return the unit to the customer until the problem is located and
corrected.

SCHEMATIC DIAGRAM (for DCD-685)

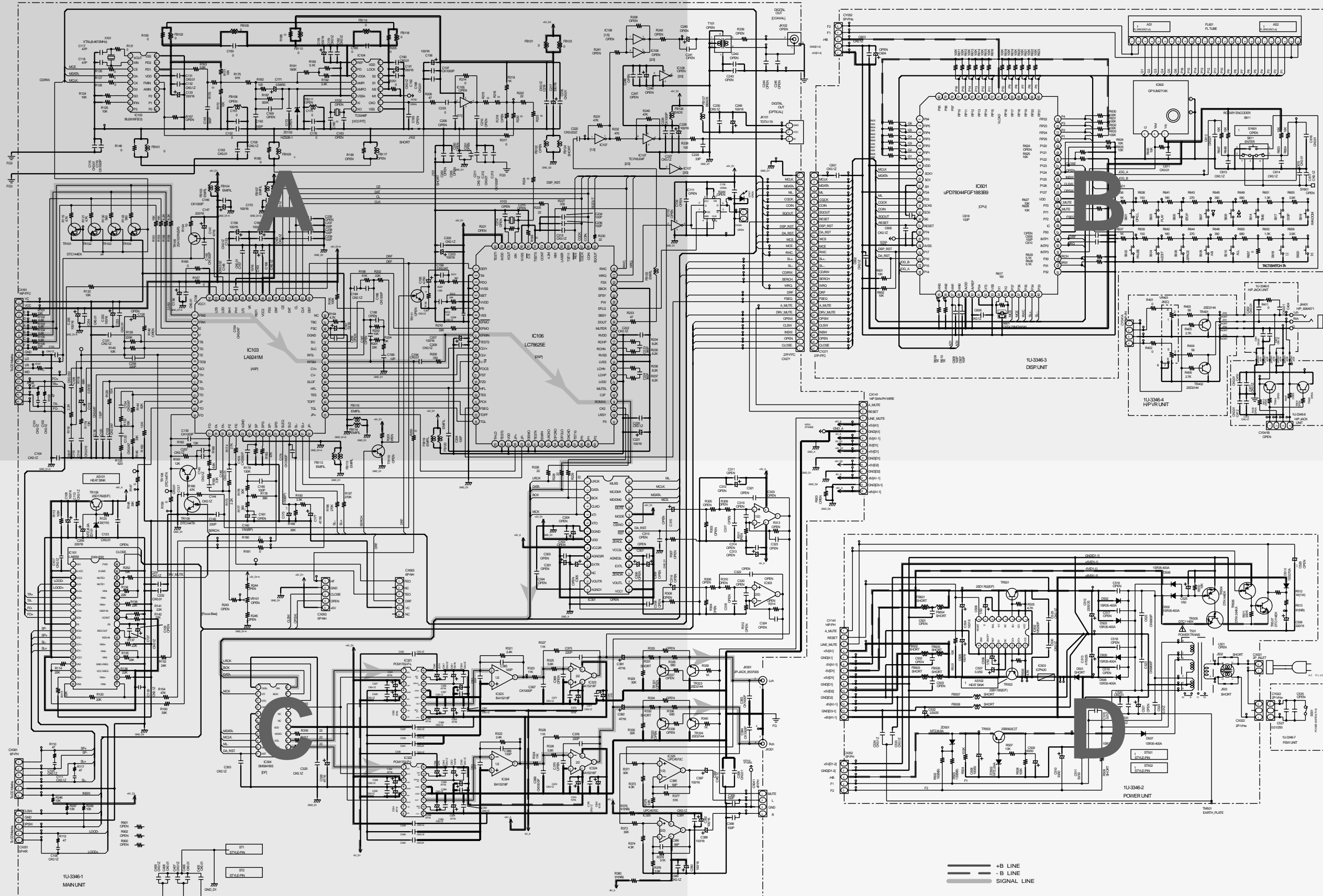

SCHEMATIC DIAGRAM (for DCD-685)
1U-3346A

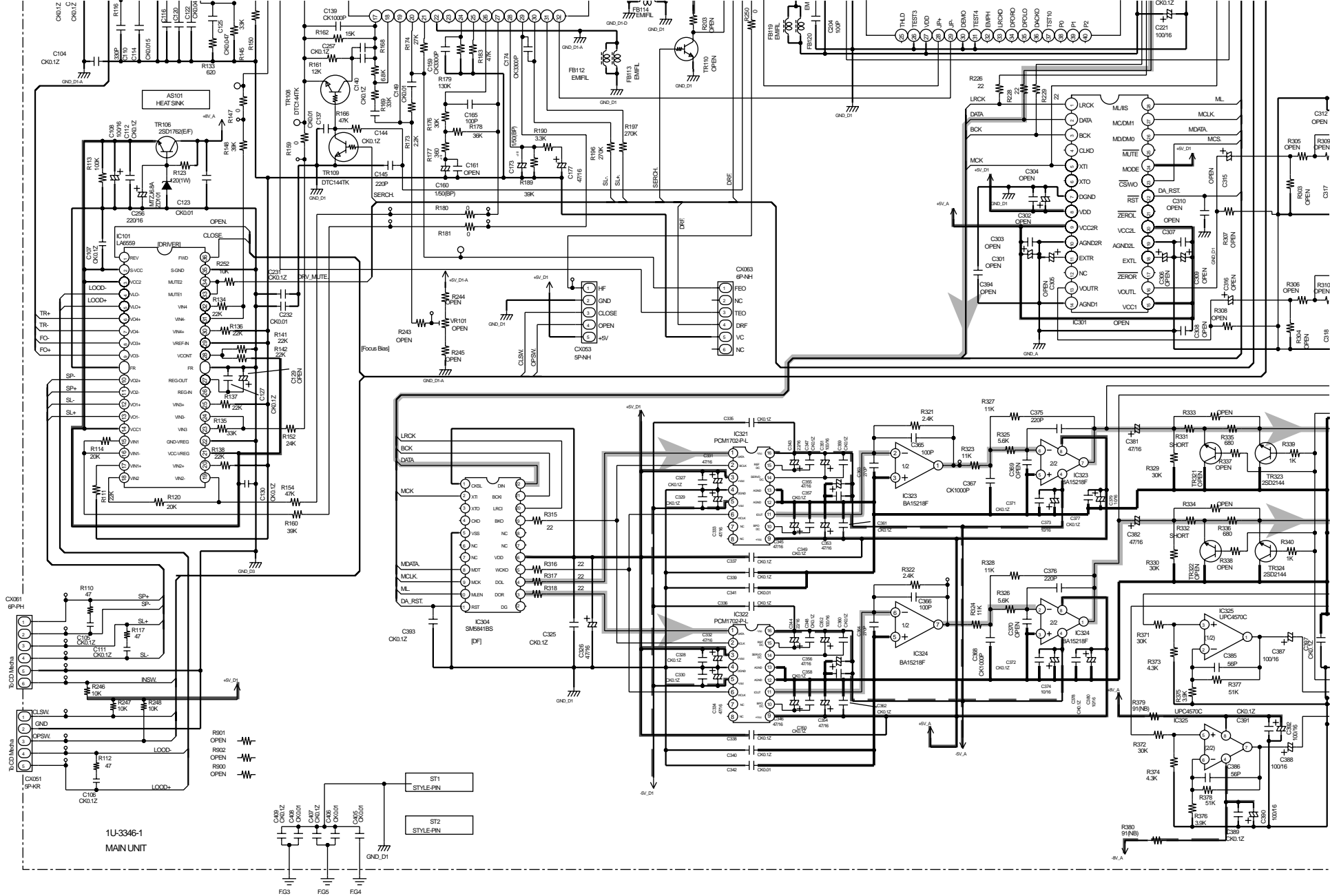

NOTICE
 ALL RESISTANCE VALUES IN OHM. k=1,000 OHM M=1,000,000 OHM
 ALL CAPACITANCE VALUES IN MICRO-FARAD. P=PICO-MICRO-FARAD
 EACH VOLTAGE AND CURRENT ARE MEASURED AT NO SIGNAL INPUT
 CONDITION.
 CIRCUIT AND PARTS ARE SUBJECT TO CHANGE WITHOUT PRIOR
 NOTICE.

WARNING:
 Parts marked with this symbol  have critical characteristics.
 Use ONLY replacement parts recommended by the manufacturer.

CAUTION:
 Before returning the unit to the customer, make sure you make either (1) a leakage current check or (2) a line to chassis resistance check. If the leakage current exceeds 0.5 milliamperes, or if the resistance from chassis to either side of the power card is less than 460 kohms, the unit is defective.

WARNING:
 DO NOT return the unit to the customer until the problem is located and corrected.

1U-3346-1
 MAIN UNIT

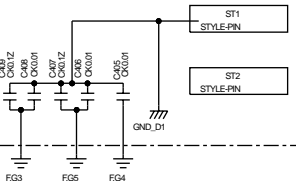

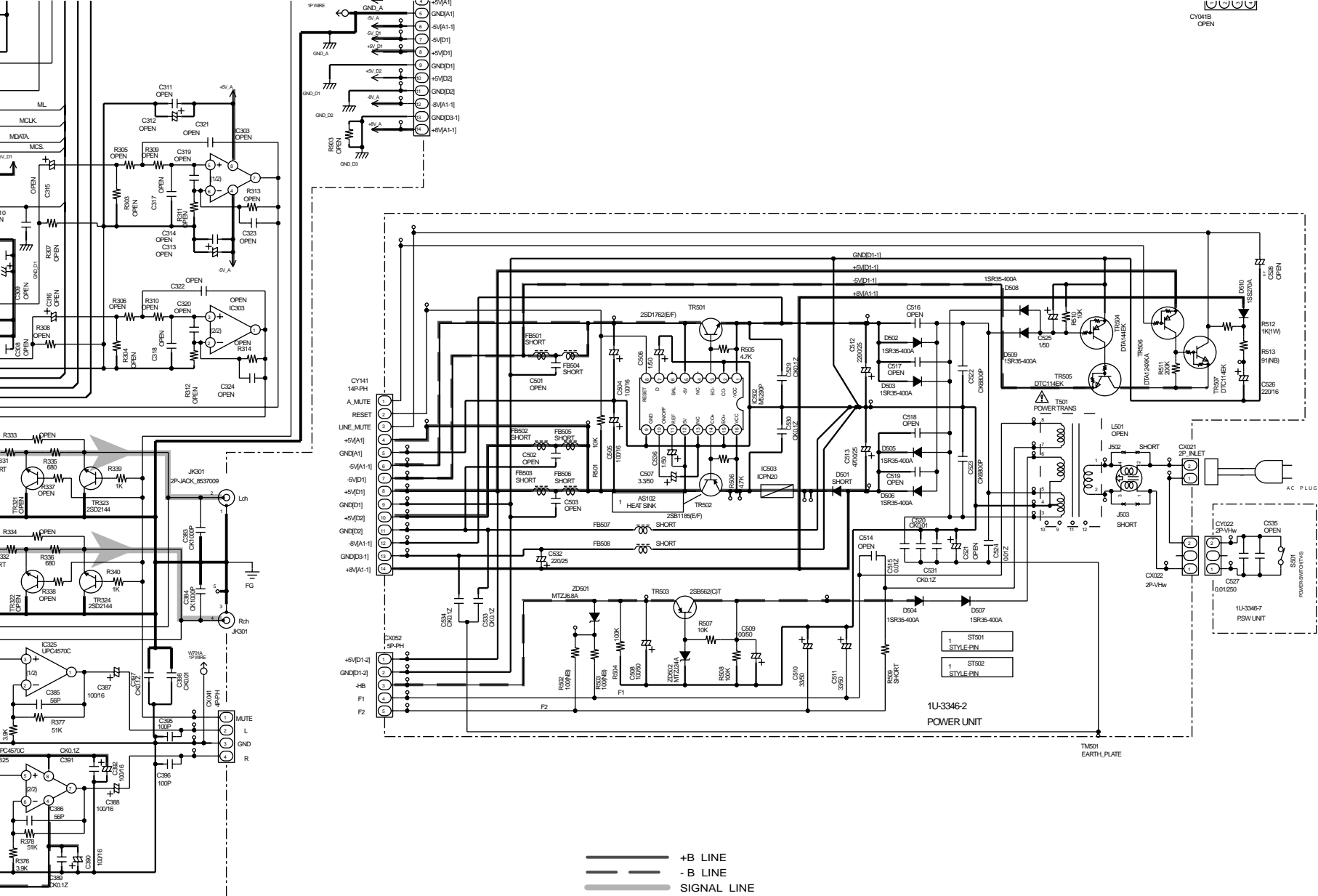

SCHEMATIC DIAGRAM (for DCD-685)
1U-3346A