

# *PERFORM!*

With Roger Powell,  
Atlantic Records Recording Artist



*ON THE  
& ARP. ODYSSEY  
SYNTHESIZER*

<http://www.arpodyssey.com/Patches/rppatches/roger-powell.html>

## Odyssey Overview

Start Tape Here: Roger Powell's Introduction

Preliminary Tuning Patch

Patch 1: Trumpet

Patch 2: Trombone/Tuba

Patch 3: French Horn

Patch 4: Flute 1

Patch 5: Flute 2

Patch 6: Clarinet

Patch 7: English Horn

Patch 8: Saxophone

Patch 9: String Chorus

Patch 10: Banjo

Patch 11: Electric Bass

Patch 12: Phase-Sync Oscillator with Pedal Control

Patch 13: Phase-Sync Oscillator with Sample/Hold Control

Patch 14: Guitar-Leslie

[Livret PDF](#)

Patch 15: Electric Harpsichord

Patch 16: Fuzz Organ

Patch 17: Fuzz-Wah Clavinet

Patch 18: Jimmy Smith Jazz Organ Patch

19: Trill-Phase with Long Envelope Patch

20: Sample/Hold Filter Harmonics Patch

21: Pitched Noise

Patch 22: Bass Drum

Patch 23: Snare

Patch 24: Conga

Patch 25: Cymbal

Patch 26: Gong/Chime

Patch 27: Sample/Hold Filter Noise

Percussion

Patch 28: Train

Patch 29: Siren

Patch 30: Surf

Concluding Remarks

[40 Minute Audio course in MP3 Format](#)

Thanks to Guy Phethean in London, England for sending this to me on tape

[Youtube : https://www.youtube.com/watch?v=Pu2JwwG3bjA](https://www.youtube.com/watch?v=Pu2JwwG3bjA)



# ODYSSEY

THE ULTIMATE  
MUSICAL TRIP

The ARP Odyssey brings polyphonic electronic music to the performing artist—rock, pop, jazz, or avant-garde. It includes such state-of-the-art "firsts" as phase-locked oscillators, digital ring modulator, sample & hold circuits, and many of the functions of a complete studio synthesizer.

With its ease of operation and high reliability, the ARP Odyssey can produce an enormous variety of sounds in live performance. Everything from thunder and lightning to gong, fuzz guitar, and feedback distortion is at your fingertips with the Odyssey's slider controls and patch switches. The Odyssey's foot pedal and foot switch add to your expressive control. Its two voice, 37-note keyboard has a 7-octave range.

Schools wishing to incorporate electronic music programs into their curricula will find the ARP Odyssey an excellent nucleus for an electronic music studio. And, of course, the famous ARP filters and oscillators give you drift-free accuracy for professional quality recordings.

*White/Pink Noise Generator.* Percussive effects.

*Portamento Speed Control.* Slide from note to note.

*Pitch Bend sharp-flat control.* Bends notes.

*Keyboard Transpose.* Raise or lower pitch of keyboard two octaves instantly.

*Voltage Controlled Oscillator I.* Exclusive pulse width modulated output.

*Voltage Controlled Oscillator II.* Exclusive phase-locked synchronization feature. Pulse-width-modulated output.

*Low Frequency Oscillator.*

*Sample & Hold.*

*Audio Mixer.*

*Voltage Controlled Lowpass Filter.* New Low-Noise design. Also serves as third VCO.

*High Pass Filter for added brilliance and unusual effects.*

*Voltage Controlled Amplifier*

*Envelope Generator I.* Exponential attack, decay, sustain, and release time. Independently variable.

*Envelope Generator II.* Exponential attack and decay.

*Keyboard-synchronized trigger repeat.*

*Two voice keyboard. 37 notes.*



Dimensions 23" x 18" x 5"  
Weight 20 Lbs.

*Rear Panel Connectors.* Portamento Foot Switch, filter Foot Pedal, and High or Low Level Outputs.

# START TAPE HERE

Hello and welcome to the world of electronic music. I'm Roger Powell and during the next 45 minutes I'll be telling you about how to use your new ARP Odyssey music synthesizer. For this course to be most effective, you should follow the instructions in the booklet that accompanies this tape. We suggest that each time you hear this tone, stop the tape and experiment with the synthesizer set-up that has just been explained. When you feel that you understand that particular set-up, then start the tape again, and we'll talk about the next instrument or sound to be synthesized.

You'll notice that the course progresses from the more familiar orchestral sounds through electric instruments, percussion and finally, sound effects. We have carefully selected 30 basic Odyssey patches in these categories to give you a good repertory of sounds. Of course, these 30 patches are by no means exhaustive; you'll probably create hundreds of other sounds by experimenting on the Odyssey. The 30 basic patches are meant to be departure points for your own inventiveness.

The aim of this course is to get you familiar with the Odyssey's controls and capabilities for live performance or studio use. *Any patch can and should be modified during performance.* This is an important concept the Odyssey was specifically designed for: fast and smooth transitions during live performance, and you'll realize the full potential of the instrument by reshaping the sound while you're playing the keyboard.



Let's get started now with the *PRELIMINARY TUNING PATCH* in your booklet. Nearly all the patches in the course are based on tuning the two voltage controlled oscillators as shown in this diagram. While depressing the lowest key on the Odyssey keyboard, adjust VCO-1's coarse and fine frequency controls until the oscillator sounds in unison with a piano or organ tone one octave below 'middle C.' Then, bring up the audio mixer control for VCO-2 and match the pitch to that of VCO-1 by adjusting the frequency control sliders on VCO-2. Now stop the tape and tune the oscillators.

## PRELIMINARY TUNING PATCH

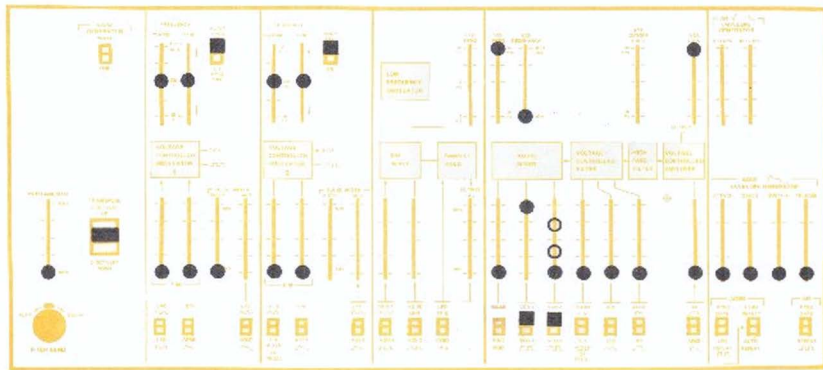

PLEASE TAKE NOTE: Control sensitivities vary from instrument to instrument, so knob settings on your Odyssey may be slightly different from those shown here. But only very slightly.

# 1. TRUMPET

Now, we're ready to begin with Patch 1, the *TRUMPET*. The most popular way of synthesizing brass instrument sounds is to begin with a sawtooth waveform. For the trumpet, we'll leave the transpose switch at mid-setting for the proper range. The ADSR envelope generator settings are very critical. Listen carefully as you adjust the attack and release controls, making sure that the attack is not too percussive or short, or that it isn't too slow. This is also true of the release control. When you adjust the filter reson-

ance control, be careful. Too much resonance will cause a 'wow' type of sound uncharacteristic of a trumpet unless you want to play in the style of Clyde McCoy who was one of the first trumpet players to use the 'wah-wah' mute. When you're playing the trumpet sound, remember the problem of breath control and phrasing that trumpet players have to think about. Don't play continuously legato on the keyboard; leave some space between notes. You should also try adding some vibrato by raising the FM control marked LFO sine wave on VCO-2. Raise that slider after starting a sustained note. The pitchbend and sometimes the portamento controls can also be used to enhance your performance.



Lowest key sounds

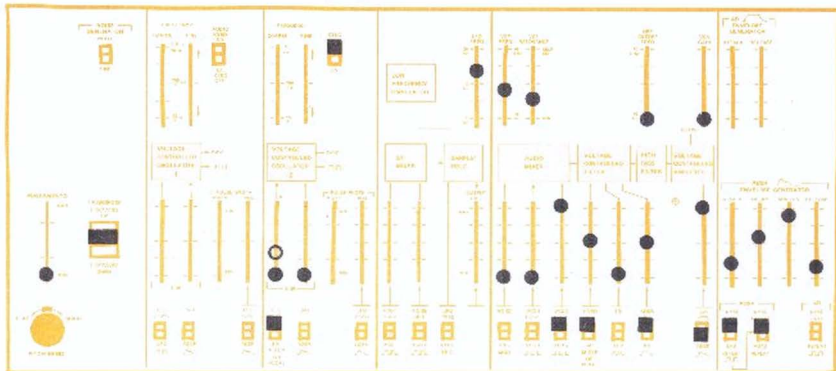

Patch 2 will give you a *TROMBONE*, *BASS TROMBONE*, or *TUBA*, depending on the register you play. For the tuba, try increasing the attack and release times on the ADSR envelope generator very slightly from the diagram. This will help to simulate the slower attack inherent in the larger brass instrument. If you're working on the slide trombone, experiment with the portamento control and pitchbend. Again, be careful not to exaggerate the filter resonance.

# 2.

## TROMBONE/TUBA

Trombone →

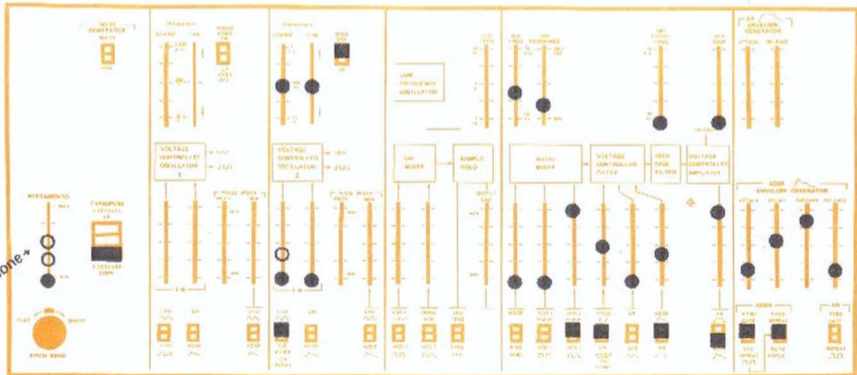

### 3. FRENCH HORN

The *FRENCH HORN* diagrammed in Patch: 3 has a softer, less brilliant timbre than either the trumpet or the trombone. This is why the filter frequency control is lowered somewhat. Also notice that the ADSR attack and release is a bit longer than for the trumpet and trombone. Remember to leave some space between individual notes for the most natural effect.

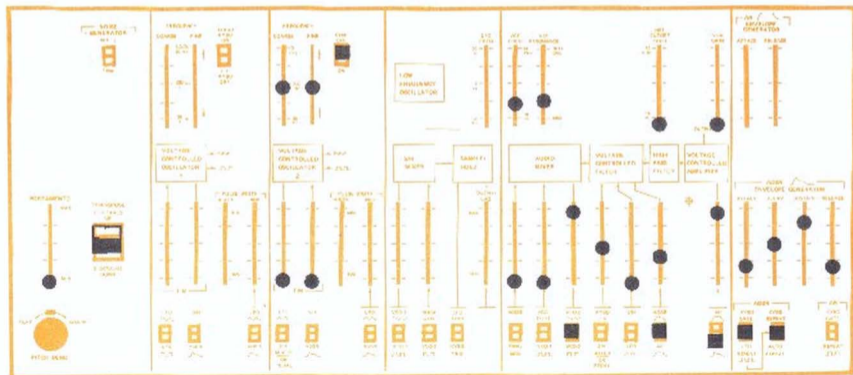

## 4.

## FLUTE 1

Patches 4 and 5 show two approaches to synthesizing a *FLUTE*. In the first, Patch 4, you'll see that the set-up is similar to those used for the brass instruments, particularly the French horn, except that the keyboard has greater control on the filter. More keyboard control of the filter is necessary because the flute sound would become very dull and muddy if the filter didn't open up and allow the higher harmon-

ics to pass as the pitch got higher. Another important key to synthesizing a good flute sound is to cause the filter to waver or flutter by applying the LFO sine wave to a filter control input. This is different from the trumpet vibrato which is actually a wavering of the *pitch*—going slightly sharp and flat at a regular rate. In the case of the flute player, his diaphragm can produce fluctuations in the air column which cause changes in the harmonics. Hence, we are concerned with modulating the filter rather than the oscillator.

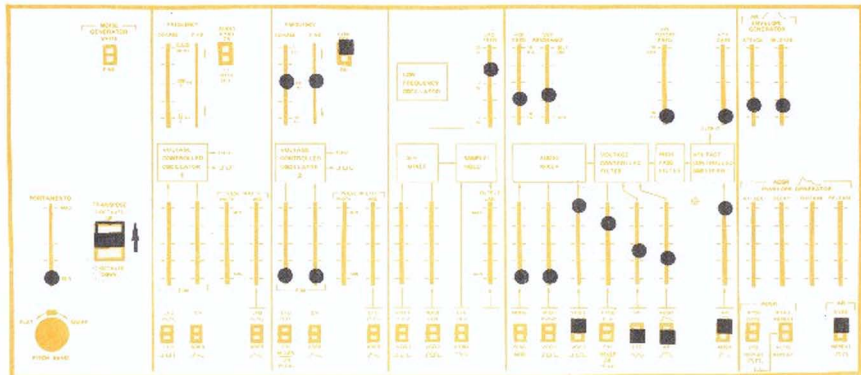

## 5. FLUTE 2

In Patch 5, *FLUTE 2*, the tone is generated by VCO-2 which is phase-synchronized from VCO-1. Note the position of the 'phase sync' switch on VCO-2. By applying the LFO sine wave and ADSR envelope generator controls to FM inputs, VCO-2, we can alter the harmonic structure of the basic sawtooth wave. Try changing the levels of these two FM controls on VCO-2 for different effects.

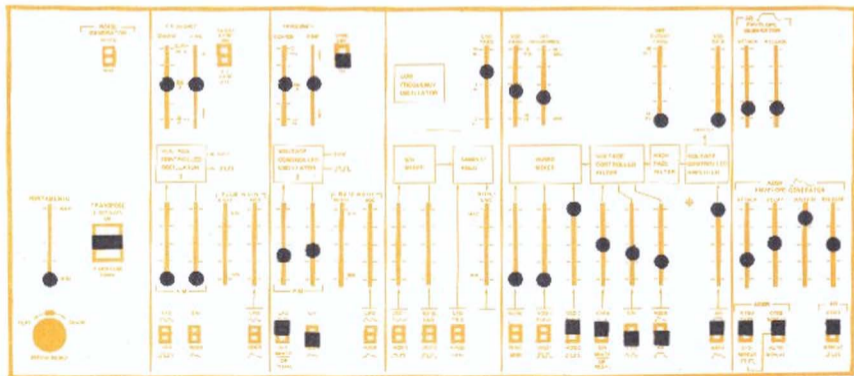

6.

## CLARINET

With the *CLARINET* in Patch 5, we begin to study the reed instruments. Unlike the brass family, the reed instruments use the square or pulse waveform as the basic sound source. Because it is made up of only the odd-numbered harmonics, the square wave has a hollow quality and sounds very clarinetlike even with-

out filtering. By using the Odyssey filter, we can process the raw square wave in two ways: first, we'll soften the brilliance somewhat by filtering out the extremely high harmonics; second, we'll add some resonance which will give the sound a woody character. This clarinet patch is useful in all three ranges of the transpose switch. Notice particularly the rich bass clarinet sound you get in the mid-to-low range. Vibrato and portamento are both very difficult on an actual clarinet; with the Odyssey, they're a simple matter and contribute greatly to the overall effect.

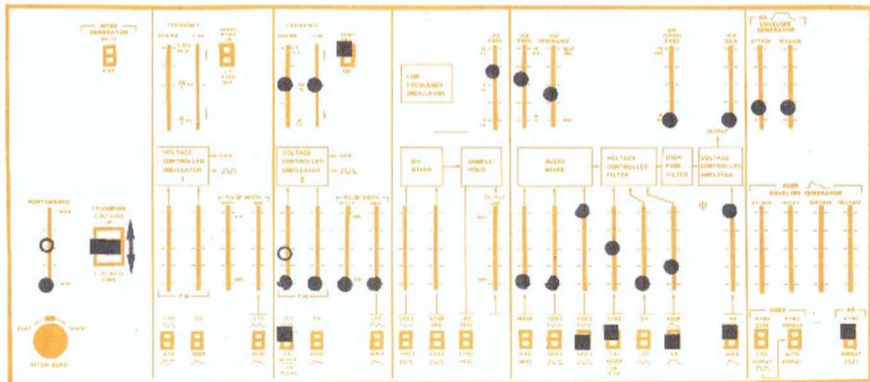

## 7. ENGLISH HORN

For the *ENGLISH HORN* in Patch 7, we use a narrow pulse wave. This wave form is achieved by changing the pulse width control slider on VCO-2 until a nasal quality is found. The English horn has a highly resonant peak in its sound which we get by increasing the amount of filter resonance. A small amount of continuous vibrato will give the sound some warmth, and, again, the pitchbend and portamento effects are useful for certain musical styles.

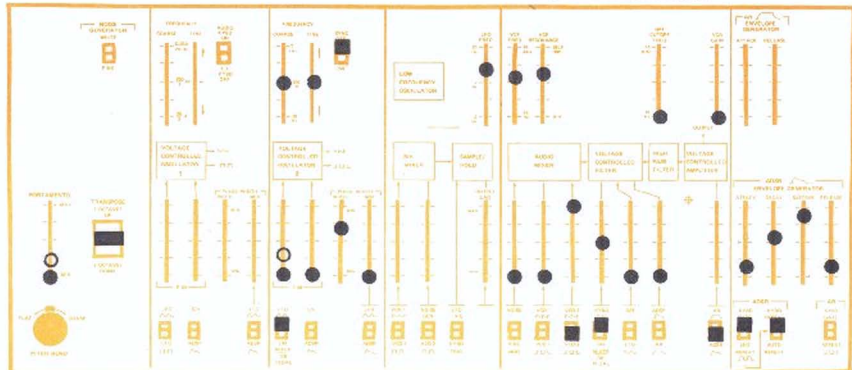

## 8. SAXOPHONE

Of all the reed instruments, the *SAXOPHONF* is perhaps the hardest to synthesize. This is because of two things: as the saxophone changes register, the actual harmonic content or timbre of the horn changes as well; and, the saxophone is such a flexible and responsive instrument that every player tends to develop his own characteristic style. The sax can sound very smooth and legato one moment and then become very biting and raspy the next. In Patch 8, we have a saxophone sound somewhere in the middle of the two extremes. The key to authentic saxophone sound is

pulse width modulation. In this example, the ADSR envelope generator is used to vary the pulse width during the attack and decay of each note. This pulse width modulation produces the buzzy sound of the large reed being set into vibration. Use plenty of vibrato and don't forget about wind instrument breath limitations and spacing of notes.

9. The voltage controlled pulse width feature on your Odyssey can also create a *STRING CHORUS* effect, as shown in Patch 9. Although you normally tune the two VCO's to unison, it will enhance the chorus effect of multiple violins or cellos to *detune* the fine tune control on one of the oscillators slightly sharp. This

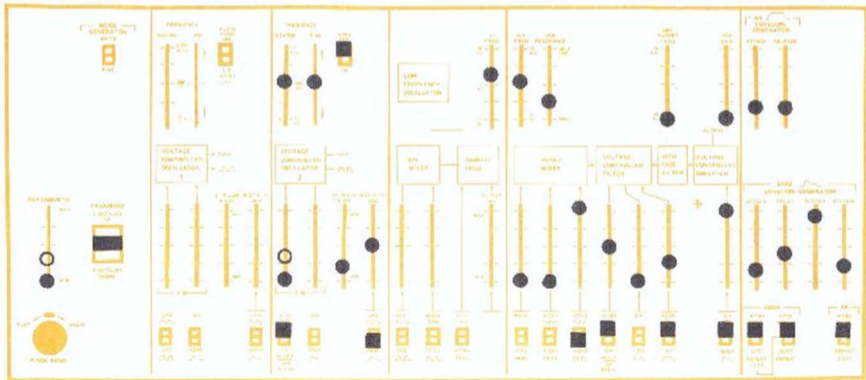

## 2-VOICE STRING CHORUS

detuning will cause beats to occur as happens naturally when two violins are sounding the same note but are not precisely in tune with each other.

The position of the VCF frequency control is critical and should be tuned carefully. If the filter frequency is set too low, the strings will sound dull; if it is too high, they will appear to be too bright. Since string instrument bodies are very resonant, we'll choose a relatively high degree of filter resonance. The vibrato rate adjusted at the LFO frequency slider should be set carefully. Remember that you are after the chorus effect of many strings; you are trying to create as many beats as possible without adversely affecting the in-

tonation. The AR envelope controls should be placed at the position which gives you the most pleasing attack and decay rates for the piece of music you're playing. If the tempo is fairly slow, increase the attack-release times for more legato playing. Generally, you'll find that a slight amount of portamento will enhance the realism of the sound by simulating the effect of the violin or cello fretless fingerboard. Increase the amount of portamento for longer glissandos. The string patch is useful in all three registers where the notes fall into the natural range of the cello or violin. For the sound of a single instrument, just pull down the audio mixer attenuator for VCO-1 and you are left with only the sound of VCO-2.

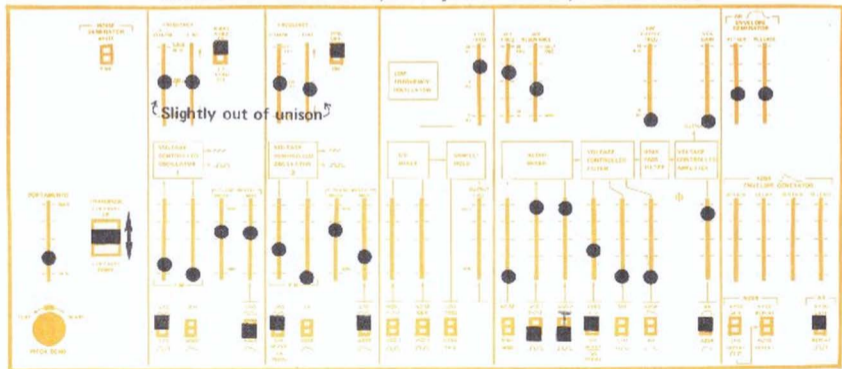

# BANJO With Repeat

The last nonamplified, traditional instrument that we will synthesize is the *BANJO* in Patch 10. In this patch, VCO-2 supplies a narrow pulse wave to the resonant filter. The ADSR envelope generator produces a short plucked type of attack and decay. If you move the first slide switch beneath the ADSR controls to the KYBD Gate position, you'll be able to play single notes from the keyboard. Move the switch down to LFO repeat, and you'll get a steady reiteration of notes while you hold a key down. You can adjust the repeat rate at the LFO freq slider.

## 10.

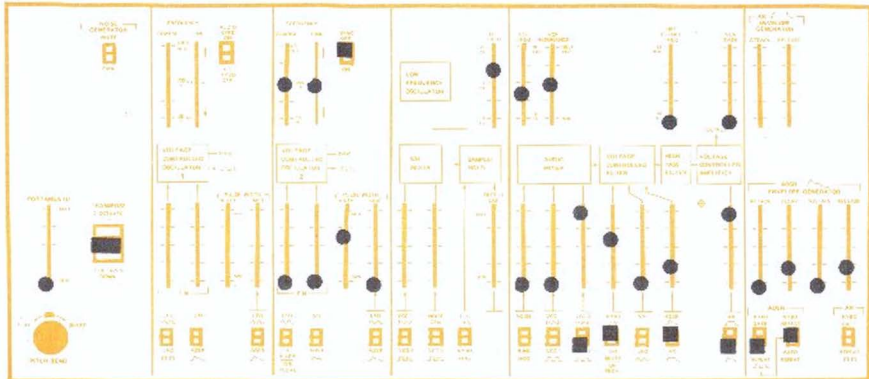

## II. ELECTRIC BASS

Our exploration of electric instruments begins with the *ELECTRIC BASS* in Patch 11. We'll use a narrow pulse wave from VCO-2 with the transpose switch in the lower position. To simulate what happens when the bass string is plucked and released, modulate the

pulse width of VCO-2 with the ADSR envelope generator. In the diagram, the envelope generator settings are adjusted for a slightly plucked sound with a medium length release. If you wish to change the envelope try moving the decay and release controls. Increasing them will cause less-percussive, more sustained notes. Decreasing them will provide pizzicato effects. You can also try changing the manual pulse width control on VCO-2. If you bring the pulse width slider down, the pulse width will widen and the sound will become fatter. Going in the other direction produces a thinner sound like an electric bass player using a pick close to the bridge of the strings.

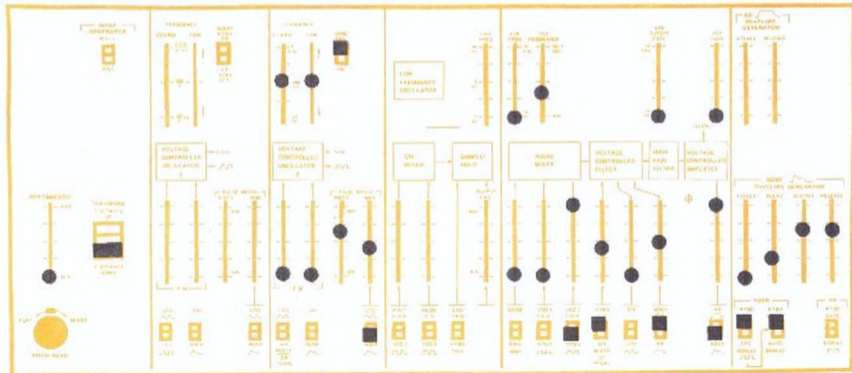

In Patch 12, we begin to create what you might call 'fantasy' instruments. These are sounds for which there are no traditional equivalents. They are sounds which can only be made on the synthesizer; several of them can be made *only* on the Odyssey because of its unique phase-synchronized oscillator capabilities. Patch 12 also uses the pedal supplied with your Odyssey. By moving the pedal up and down, you can scan the harmonic spectrum of the sound without changing the pitch of the note you're playing.

You can experiment with the ADSR envelope generator controls; we've set them to simulate the effect of an *OVERAMPLIFIED GUITAR*. This is a general purpose solo voice patch and should be modified freely.

## 12.

# PHASE-SYNC

Oscillator with Pedal Control

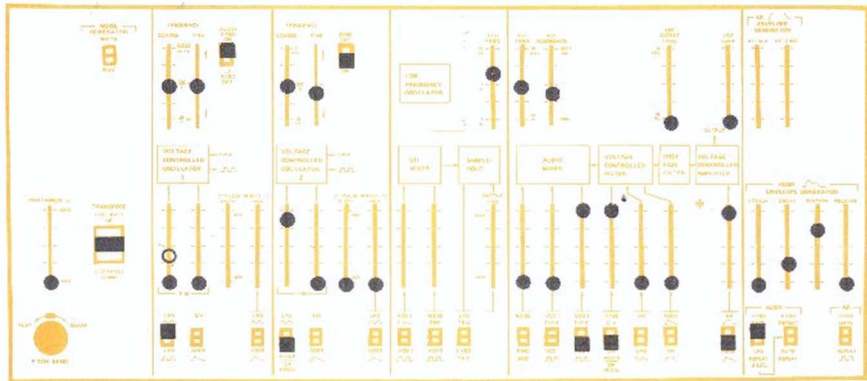

# 13. PHASE-SYNC

Oscillator with S/H Control

Patch 13 is similar to the previous patch except that the changes in the phase-synced oscillator will happen at random, controlled by the sample and hold circuit. Each time you depress a key, even if it is the same key you just played, the timbre will change. The amount of timbre change can be regulated by increasing or decreasing the S/H attenuator on VCO-2. We have also 'lagged' the output from the S/H circuit so that the fluctuations in timbre will occur in a fluid manner after each key is depressed. Decreasing the lag control will cause the timbre changes to happen more instantaneously.

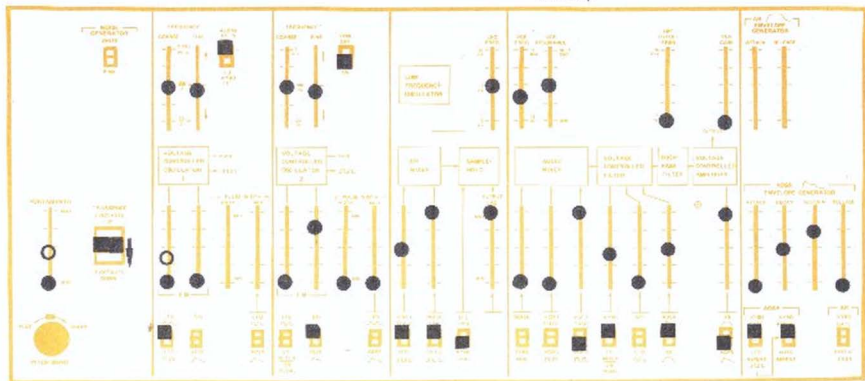





# FUZZ ORGAN 2-VOICE

Patch 16 is called a *FUZZ ORGAN* sound. What we mean is an organ played through a blown speaker cone. This produces a type of distortion which can sound very pleasing and is useful for lead solo lines. We achieve this distortion electronically by use of the ring modulator. Whenever you play two different notes simultaneously on the keyboard, you are selecting two frequencies to be fed into the ring modulator from VCO-1 and VCO-2. When these two frequencies

meet in the modulator, new frequencies called 'side bands' are produced which have harmonics equal to the sum and difference of the frequencies of VCO-1 and VCO-2. Musically speaking, the output from the modulator is the pure distortion. So if you mix a little of the ring modulated sound in with the straight, unmodulated signals from VCO-1 and VCO-2, you'll get the fuzz distortion effect without having to blow out a good speaker. Here again, experiment with other settings for the ADSR envelope generator and VCF if you like. Vibrato may be desirable also and you should become skilled at moving the LFO sine wave input sliders on both VCO-1 and VCO-2 simultaneously.

16.

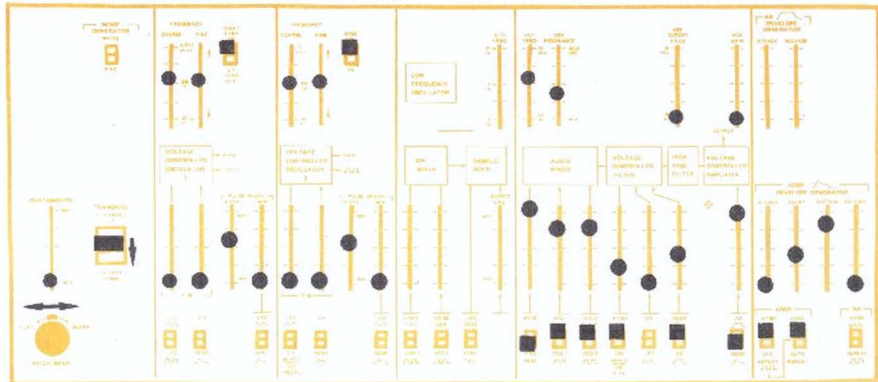

# 17. FUZZ-WAH CLAVINET

Patch 17 is really an extension of the previous patch with foot pedal filter control added for *WAH-WAH EFFECTS*. We've also narrowed the pulse waves for a more string-like timbre. This sound is particularly effective in the low transpose range.

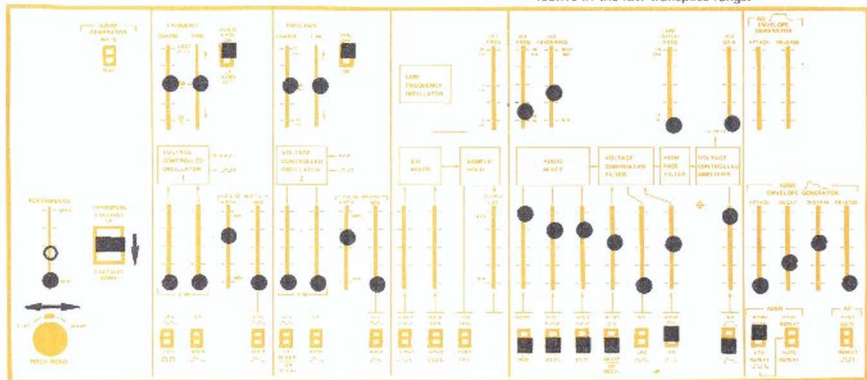



# 19. Trill-Phase

with Long Envelope

In the next few patches, we'll explore some synthesizer effects voices—sounds which are indigenous to the synthesizer and are impossible or very difficult to produce on any other instrument. The first of these is Patch 19, the *TRILL/PHASE with long envelope*. This title describes much of what is going on in the

Odyssey. VCO-1 is being made to trill between two notes at an interval you regulate by adjusting the LFO square wave input to VCO 1. As shown in Patch 19, VCO 1 will produce roughly a musical fifth trill. The speed or rate of the trill can be adjusted with the LFO freq slider. At the same time that this trilling is happening, the LFO sine wave is modulating the pulse width of VCO 1, producing a pleasing effect. The pulse width of VCO-2 is being changed by the ADSR envelope generator which is set to provide very long, sustained envelopes. The result is a very rich, undulating, 'spacey' sound, very useful in the high register on slow melodic passages.

Tune for desired trill interval  
(5th as it stands)

Tune for trill speed

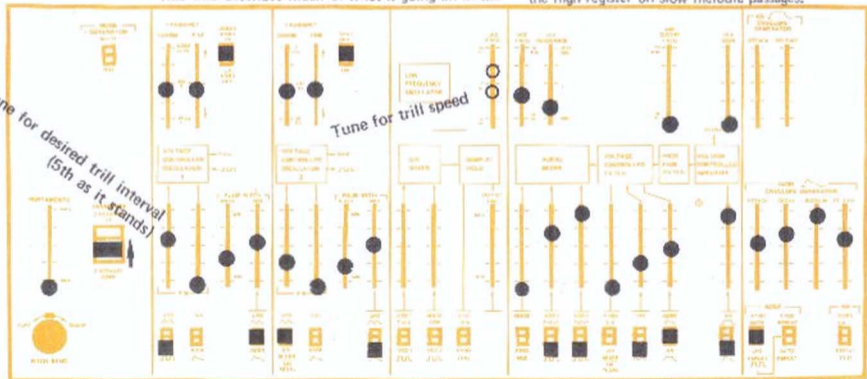

Patch 20 shows a way to use the filter and S/H circuit to produce a shifting harmonic texture. We suggest that you tune VCO-2 a musical fifth higher than VCO-1. This tuning is particularly rich in harmonics and overtones. By using the S/H circuit to control the VCF freq, you'll hear a continually shifting overtone series as long as you hold down a key. The rate of changes is set by the LFO freq slider. Try increasing the S/H control signal going into the VCF by raising the yellow slider labeled S/H. Raising this slider will produce a wider range of harmonic change. This patch is useful as a harmonic and rhythmic background texture.

# 20.

S/H Filter

## HARMONICS

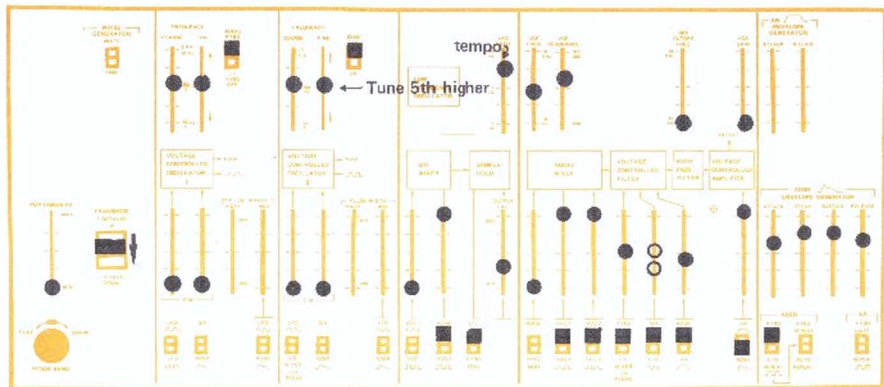

## 21. PITCHED NOISE

In Patch 21, the combination of the noise generator, VCF, and keyboard allows you to 'play' the *NOISE*. Passing the white noise signal through the VCF with high resonance filters all the frequencies except for a very narrow band which gives the noise a 'pitched' sound. In the patch, the VCF freq is controlled by the keyboard so that a musical scale can be played. The ADSR envelope generator controls have been adjusted for a sharp attack and a moderate release time. You can change these controls freely to get the exact effect you want.

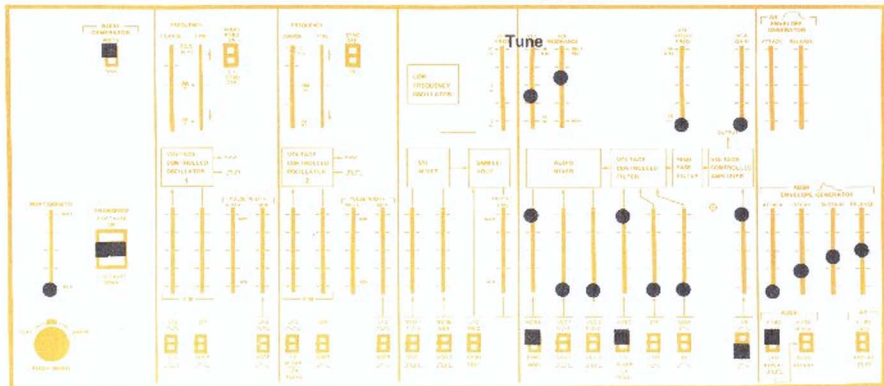



this patch is that we are frequency-modulating VCO-2 by VCO-1 to produce a metallic ringing present in a true snare drum sound. Normally, you'd use the ring modulator for this metallic timbre, but we need the noise generator at the same time for this patch. The switch arrangement selecting inputs to the audio mixer precludes using both the noise generator and ring modulator simultaneously. So we'll simulate the ring modulator sound by feeding VCO-1 into an FM input on VCO-2. This is done in a round-about fashion. If you disconnect the pedal from the back of the Odyssey, the output of the S/H mixer will appear at the input of VCO 2 labeled 'S/H Mixer or Pedal.'

# SNARE

## Equivalent

In Patch 23, the square wave output from VCO-1 is passed through the S/H mixer and then into the FM input on VCO-2. Adjust the frequency slider of VCO-1 for the desired metallic timbre; the settings in the diagram are only approximate. To keep a constant sound, select and play only one key. Changing notes will cause variances in the sound which you may not want for the snare drum equivalent.

Play one key only.

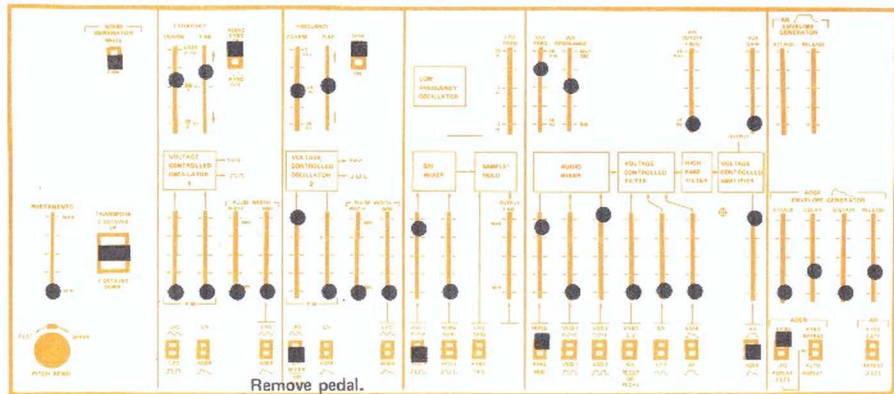



## 25. CyMbal

Patch 25, the *CYMBAL EQUIVALENT*, again uses VCO-1 to modulate VCO-2 via the S/H mixer with the pedal removed. The modulated VCO-2 is mixed with white noise and passed through the VCF. Be careful to set the VCF frequency slider at the point which produces the desired amount of brilliance. It should not produce a whistling sound; if it does, the resonance control is set too high and the frequency control is set too low. The ADSR release time adjusts the length of the cymbal crash. Except for the amount of force used, play the keyboard in the same manner that you would strike a cymbal—just a quick tap—and then listen to the dying away of the crash.

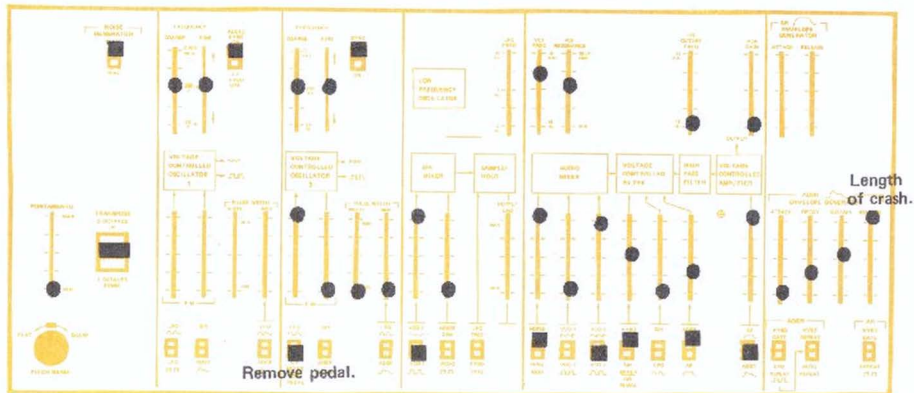

## 26.

## GoNG/ChIME

In Patch 26, we'll need to deviate from the original oscillator tuning to get the most realistic *GONG* or *CHIME* sound. The key to the gong sound is the ring modulator. Depending on the tuning ratio between VCO-1 and VCO-2, the modulator will create anything from a tiny bell to a large chime or gong. While test-

ing notes on the keyboard, change the tuning of either or both VCO's until you are happy with the modulator output. If you're working on a gong sound, we suggest that you add a small amount of slow sine wave modulation to both VCO-2 and the VCF. This will help create the slowly undulating effect that might happen if you were hitting a large gong. The ADSR release control is very important, and in most cases should be left at maximum setting to simulate the chime's naturally long resonant decay.

Tune for metallic, 'chime-like' sound.

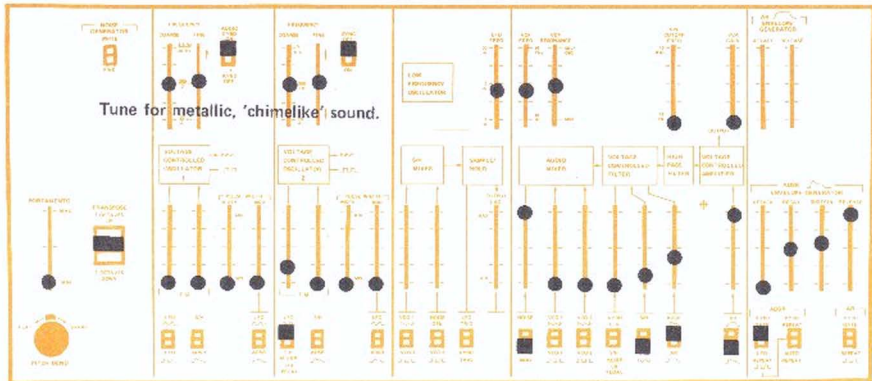

# 27.

S/H Filter Noise

## PERCUSSION

Patch 27 shows a *REPEATING PERCUSSION* effect created by noise, the VCF, and the S/H circuit. The LFO triggers the ADSR envelope generator at a steady repetitive rate. Each time the envelope generator is triggered, the S/H circuit sends a new control voltage into the filter to change its frequency. In this patch, experiment with the inputs to the S/H mixer for producing different rhythmic patterns and variations.

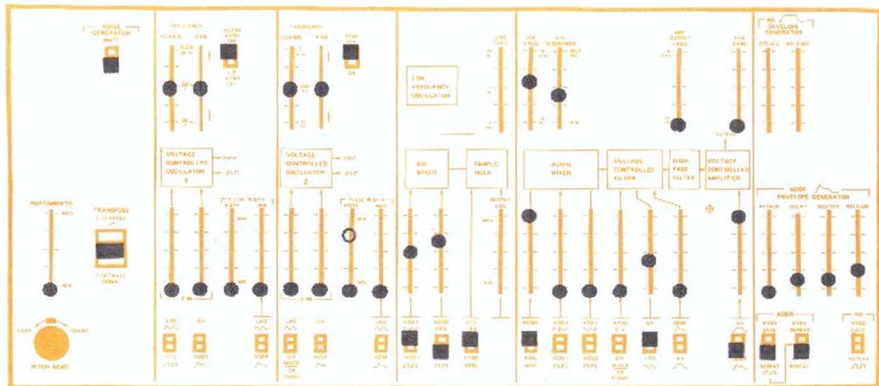

The first sound effect that we'll synthesize is the *TRAIN* shown in Patch 28. The chief sound source is the pink noise generator. The sawtooth waves from VCO-1 and VCO-2 can be added occasionally for a *horn effect*. For the *rhythmic rail effect*, we apply the S/H output to the VCF control input. This will cause slight random variations in the VCF frequency. Manually raise the VCF freq slider for a brighter out-of-tunnel sound or lower it for a dull in-the-tunnel effect. Raising the audio mixer sliders for VCO-1 and VCO-2 will produce a distant horn sound.

## TRAIN 28.

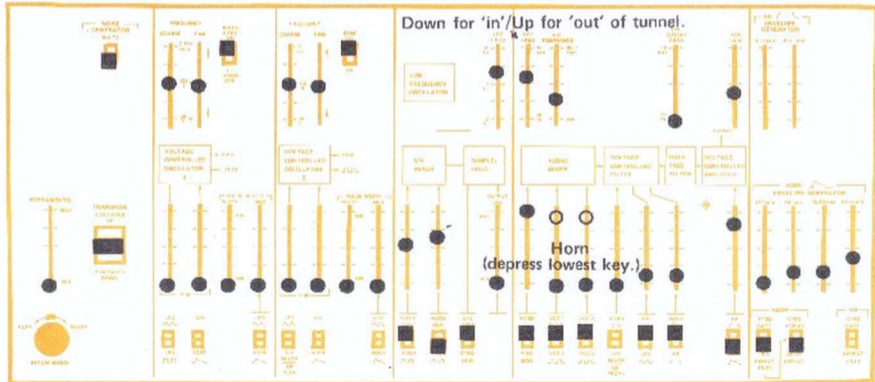

## 29. SIREN

The *SIREN*, our next synthesized sound effect, Patch 29, uses the sawtooth wave from VCO-2 as the sound source. The ADSR envelope generator controls the pitch of the VCO-2 to create the rising wail of a siren. The ADSR also controls the VCF frequency to increase the brilliance of the sound as the pitch reaches its maximum level. We've also added a small amount of LFO sine wave modulation of the VCF at a fast rate. This produces a slight 'burr' or flutter to the sound that enhances the realism of a screaming siren. As it is diagrammed in Patch 29, the best effect will be achieved by playing the second 'C' from the left end of the keyboard.

Play second 'C' from bottom.

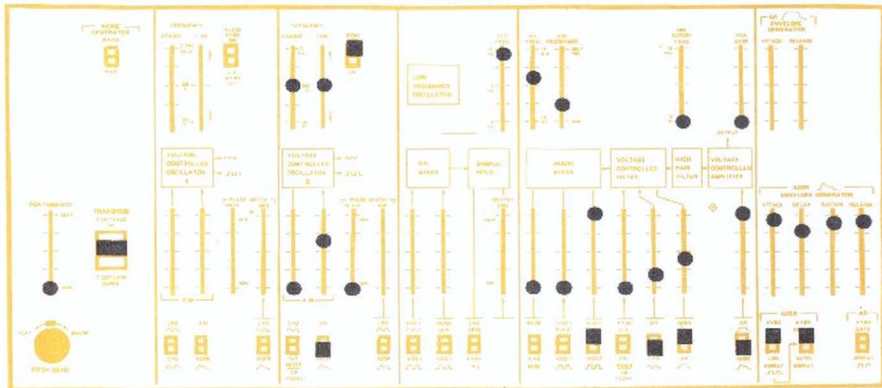



Extra pads of these blank panel sheets are available from the ARP Instruments Literature Department, 320 Needham St., Massachusetts 02164, for \$.50 each or \$5 a dozen, prepaid.

Well, that concludes our study of 30 basic Odyssey performance patches. I hope that you gained enough knowledge and experience through repeated listenings of this tape and practicing the sounds on your own Odyssey to be able to explore the thousands of other Odyssey sounds still waiting to be discovered.

For every sound I've demonstrated here, there are a hundred others which you will discover on your own. The Odyssey is designed to be a creative tool so that each of us musicians can develop a sound that is uniquely ours. With a little practice and some imagination, you'll be able to perform like you never dreamed possible. Just let your imagination go and the Odyssey will take you on the ultimate musical trip.

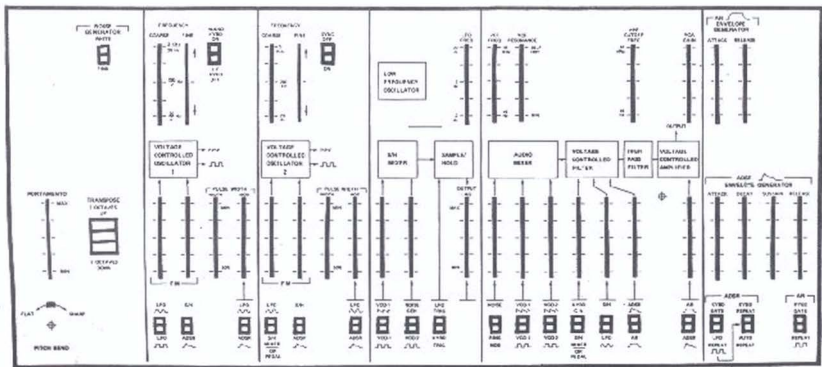

# ARP ODYSSEY

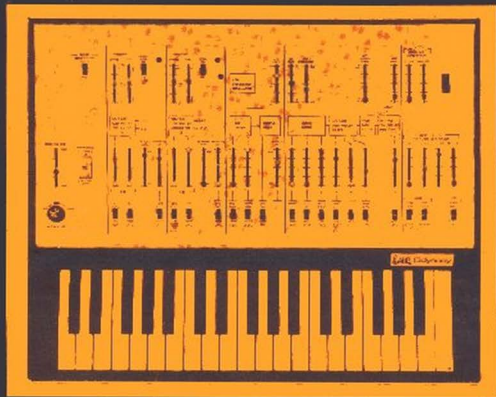

OPENING AND CLOSING MUSIC

"Tensegrity," from the Atlantic album *COSMIC FURNACE SD 7251*  
Copyright 1973 Intermedia Music

OC173 Printed in USA