

MELLOTRON 400



**OWNER'S
MANUAL**

THE MELLOTRON 400N

CONTENTS

PREFACE

1. Introduction
2. Playing the Mellotron
3. Sound Systems for the best results
4. Delivery and installation
5. The Mellotron system
6. Mechanical features
7. Electronic features
8. Recording for the Mellotron
9. Fitting the $\frac{1}{4}$ " tape guide conversion kit
10. Maintenance procedures and fault finding
11. Routine maintenance

PREFACE

THE APPLICATION OF MAGNETIC TAPE TO MUSICAL INSTRUMENTS

Hitherto, there have been many attempts to apply the principles of magnetically recorded tape to supply the basic tones needed for electronic organs. These have usually been variants of the endless loop system, and have met with varying degrees of success. However, the continuously driven endless loop has serious drawbacks if the full possibilities of recorded tape are to be exploited.

One of the attractive features of the recorded tape system is that the sound of a musician playing a note on an instrument is available and not an electronic synthesis of the same tone. It is obvious, however, that a musical sound is identified not only by the pitch and timbre of the sound but also by the way in which it starts, or is "attacked". On the continuous loop system, this characteristic start is not available since there is no way of knowing at what point of the loop playing will commence when the key is depressed. Thus it would not be feasible to try to reproduce a piano or guitar by this system.

From the foregoing, it can be seen that what is required is a system where the playing of the tape can be commenced from a known point, the tape returning rapidly to that point after the key is released. The MELLOTRON has been designed to meet these requirements.

MELLOTRON 400 — INTRODUCTION

SECTION I —

Introduction

The Mellotron 400 is a musical instrument with its sounds derived from magnetic tape recordings of live musical instruments. These tapes are fed into a loop storage system and played by a conventional keyboard.

The Mellotron 400 (fitted with the standard tape frame) provides three basic sounds, namely: FLUTE, VIOLINS and CELLO recorded on three tracks of a $\frac{3}{8}$ " wide magnetic tape.

Any one of these sounds may be immediately selected by means of a mechanical track selector control located on the Control Panel.

A variable Capstan Motor Control drive enables the pitch of the recordings to be set by the player. Volume and tone controls are provided and, in addition, provision is made for a foot operated swell pedal.

A feature of the Mellotron 400 is the ability to change a complete set of recordings in a few minutes. This is achieved by so constructing the vertical frame, on which all the recordings are housed, to be easily removable. Access to the vertical frame or removable tape frame is gained by removal of the complete keyboard assembly. No tools are required for this purpose.

The instrument has no built-in main amplifier or loudspeaker system, but is designed to connect directly into any external amplifier system or mixing console. A direct line output jack is provided for this purpose.

Normally, the Mellotron accepts $\frac{3}{8}$ " wide triple track tape, but now a conversion kit can be supplied so that $\frac{1}{4}$ " full track or 2 track recordings will be accepted. This now means that the Mellotron 400 may be used to reproduce any sound recorded on standard play $\frac{1}{4}$ " tape.

Technical Specification

HEIGHT: 34" (86cm)	WIDTH: 34" (86cm)
DEPTH: 22" (56cm)	WEIGHT: 122lbs (55kg)
POWER SUPPLY. Transformer tapped at 115V, 220V, 240V 50 or 60cps. Single phase. Consumption: 75 VA	
OUTPUTS:	1. Unbalanced line output via 2 circuit jack, 2. 3 volts into 5K ohms, via foot swell pedal. 3 volts into 600 ohms without foot swell pedal.
SIGNAL TO NOISE.	Better than — 55 dBM.
TAPE VELOCITY:	Normal $7\frac{1}{2}$ i.p.s. variable speed range $\pm 15\%$
REPRODUCE FREQUENCY:	50 HZ — 12 KHZ ± 3 DB Reproduce characteristic modified NARTB standard.
TONE CONTROL:	12dB cut at 10 KHZ
REPRODUCE HEADS:	Low impedance: 3 MH: 35 in total

SECTION II —

Playing the Mellotron

It is most important to realise that the Mellotron system allows any sound of any instrument to be played on a keyboard. This simple fact will, to an extent, limit what can be done musically with that instrument. So much depends on how it was recorded, for example, on the standard Mellotron there are three violins recorded on one note. The players were asked to play without changing direction of their bows for eight seconds. The resultant sound lends itself to legato playing because of the way in which the musicians originally played their instruments. The flute, however, will respond in a different manner and can be used effectively as a solo instrument played first in single notes or chords.

The mixing of two adjacent tracks offers completely different orchestral sounds. For instance, the violins mixed with cello presents a large orchestral effect.

SECTION III —

Sound Systems for the best results

Since the Mellotron 400 has no built in main amplifier or speaker system the resultant quality achieved will very much depend on the amplifier and speaker system used in conjunction with the instrument. Guitar amplifiers and speaker systems are designed with certain characteristics suitable for that instrument only and, therefore, the best results may not be achieved on certain Mellotron voicings used with this equipment. It is also important to note the output characteristic of the Mellotron 400 in order that it can be matched correctly to the input stage of the amplifier system employed. This is especially important where a commercial instrument amplifier is to be used as, generally speaking, a low impedance input is not provided. Using a Mellotron through a high impedance channel will generally give distortion and a very high background noise. In this case, a suitable line transformer or attenuator should be employed.

If the facilities of a mixer feeding a P.A. amplifier/speaker system are available then the output of the Mellotron should be directly injected into the low impedance channel of the mixer. This method usually ensures a better control of not only the overall balance of sound but also a control of the individual sounds of the Mellotron.

It should be remembered that all Mellotron recordings are dry — that is to say that no reverberation or echo is present on the recordings. If the Mellotron is played in a large hall with certain reverberation characteristics the effect achieved will be particularly natural, as it would for any concert orchestra. However, if the Mellotron is played in a small room or studio where there is no natural reverberation then obviously, the resultant sound will be very dull. In these circumstances reverberation or echo would be required in order to achieve a "live" quality.

THE MELLOTRON SYSTEM

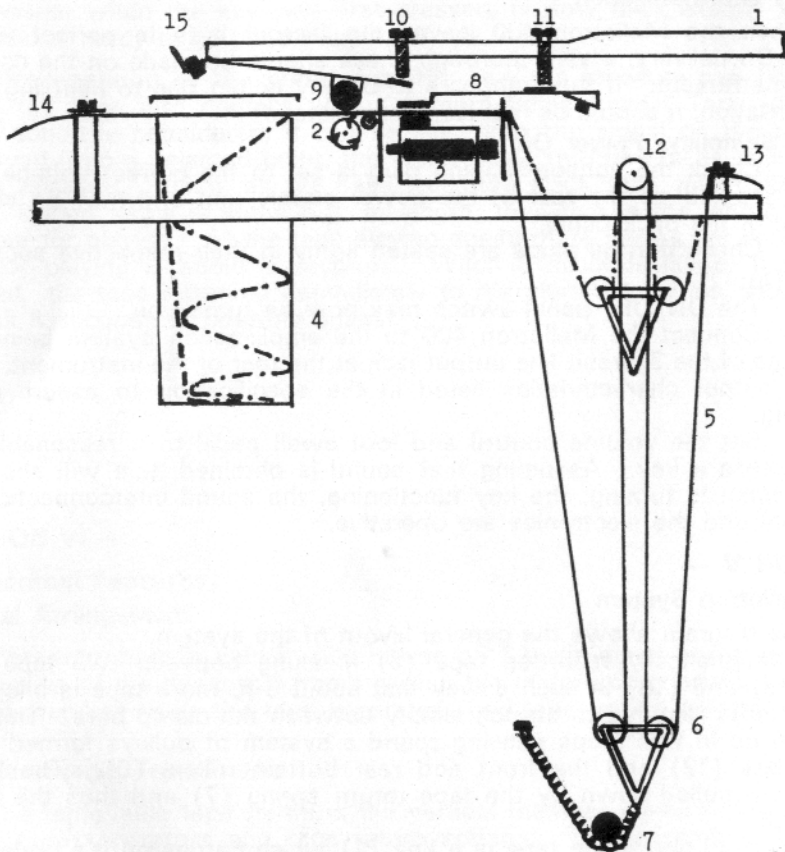

1. Key
2. Capstan
3. Head Block Assembly
4. Tape Storage Box
5. Tape
6. Bottom Roller Assembly
7. Return Spring Guide
8. Pressure Pad
9. Pinchroller
10. Pinchroller Adjustment Screw
11. Pressure Pad Adjustment Screw
12. Top Roller
13. Front Tape Clamp Bar
14. Back Tape Clamp Bar

SECTION IV —

Delivery and Installation

When the Mellotron 400 leaves the factory it is in perfect working order. On delivery, a very thorough check should be made on the condition of the instrument. If there appears to be any defect due to handling during transportation, it should be reported immediately.

Before Switching Power On:

1. Check the voltage tapping plug is set to the correct voltage. This plug is located on the rear of the power supply unit and may be seen on removal of the back panel.
2. Check that all plugs are seated firmly in their respective sockets.

Power On:

1. The ON/OFF panel switch may now be turned on.
2. Connect the Mellotron 400 to the amplification system being used by means of the 2 circuit line output jack at the rear of the instrument. Refer to the output characteristics listed in the specification to assure correct matching.
3. Set the volume control and foot swell pedal to a reasonable level and depress a key. Assuming that sound is obtained, this will show that the Capstan is turning, the key functioning, the sound interconnections are complete and the electronics are operative.

SECTION V —

The Mellotron System

The diagram shows the general layout of the system.

A magnetically recorded tape (5) is slung between two tape clamp bars (13) and (14) in such a way that about 6-ft. more tape is allowed to hang than is required to stretch simply between the clamp bars. This slack is taken up in two loops passing round a system of pulleys formed by the top rollers (12) and the front and rear bottom rollers (6). The bottom rollers are pulled down by the tape return spring (7) and thus the tape is kept tight.

Mounted above the tape is a key (1) which carries on its underside a pinchroller (9). When the key is pressed, the tape is squeezed or pinched between the pinchroller and the capstan (2). The capstan is a round bar which is made to rotate at a constant speed. Thus the tape is made to travel towards the rear of the machine at a constant speed by the action of the capstan. As the tape is driven, the expended tape falls in free folds into the tape storage box (4), whilst at the same time the length of tape absorbed by the pulley system is reduced. This means that the bottom rollers rise as the tape is used up until finally, when the rollers reach the limit at the top of their permitted travel, a length of about 6-ft. of tape has been played into the tape storage box. The dotted line shows the tape in a position near to the end of the playing action. If at this point the key is released, removing the driving force on the tape, the pull of the tape return spring on the lower rollers will remove the tape from the tape storage box and pull the loops downwards until the tape is tight again.

Since the rear tape clamp (14) has held the tape firmly in position throughout this action, it is clear that the part of the tape that was over the capstan when the key was first pressed, is now back exactly where it was before, ready to be played again.

Also operated by the pressing of the key is a pressure pad (8) which forces the tape into contact with the reproducing head. Thus when the above action is considered, it can be seen that the signal on the tape can be played from a selected point, this point being returned to as soon as the key is released. Since, as we have said, the slack tape taken up by the spring loaded loops is some 6-ft. in length, then this is the length of tape available for playing. At the tape playing speed of $7\frac{1}{2}$ inches per second, the time for playing is about 8 seconds. When 8 seconds is up, the key is released, the tape returning immediately to its starting position, after which the full 8 seconds is possible again.

SECTION VI —

Mechanical Features

General Arrangement

The instrument is built in two halves on a basic metal framework. The top portion of the horizontal frame carries the major components, whilst the vertical member holds the tape separators and tape return springs

The Removable Tape Frame

The removable tape frame is the vertical member which holds the tape loops, tape separators and tape return springs. This assembly locates in front of the front tape guide and is fastened by means of two large finger screws to the horizontal frame.

The function of the tape storage loops is to return the tape to its original position after playing. Following the path of the tape through the loops, the tape after leaving the front tape clamp bar drops to the frontmost bottom roller. It then rises and passes over the top roller, after which it falls again to pass round the rear bottom roller. Finally, it rises and enters the tape guide having passed a support bar. The bottom rollers are mounted in an enclosed assembly which is secured to the horizontal rail by a spring and a cotter pin.

To prevent adjacent tapes from interfering with each other, the vertical tape separators have been incorporated. These are shaped sections of plastic material tensioned between two rows of pins.

HEAD BLOCK ASSEMBLY

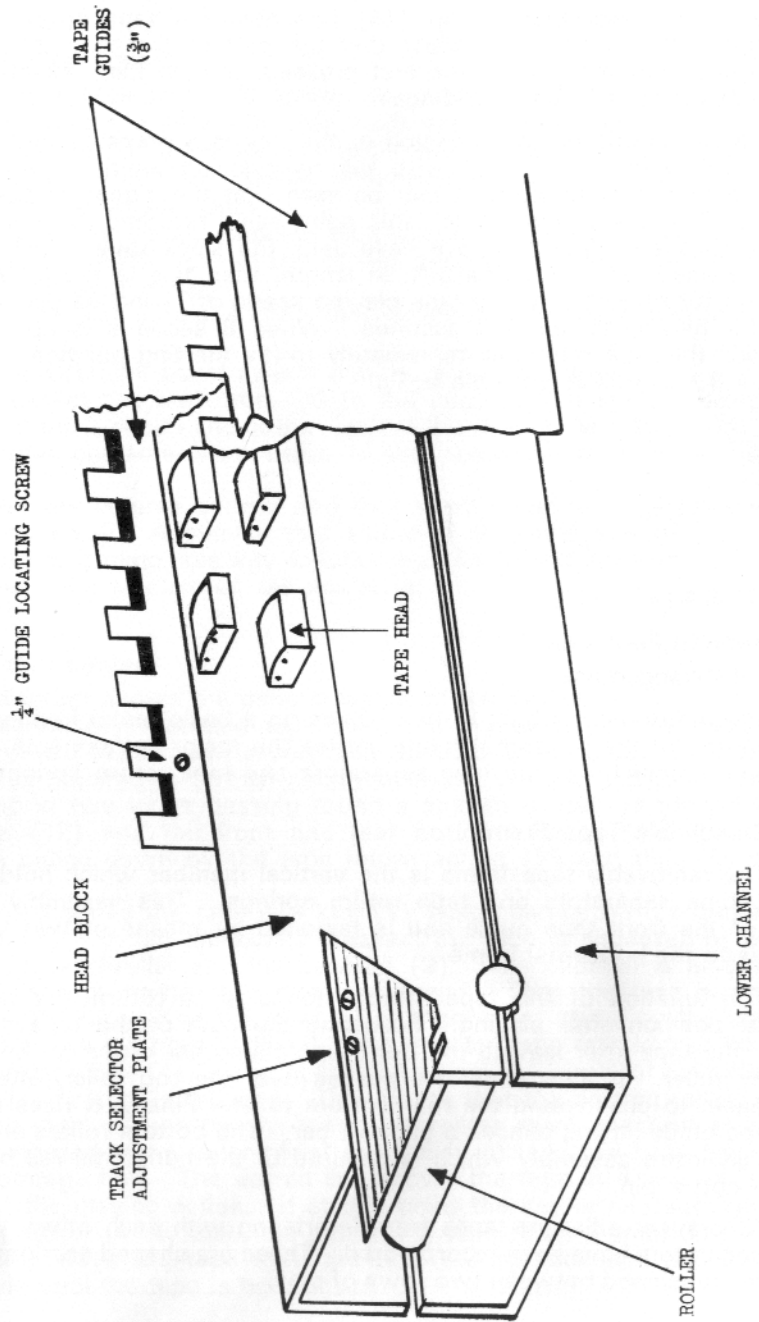

The Tape Heads

The tape crosses the reproducing heads immediately after leaving the storage loops. The tape is correctly positioned with respect to the heads by the front and rear tape guides. The slots in the guides are only approximately .005" wider than the tape and so care must be taken to see that no damage occurs to them.

The tape heads are mounted in channel section aluminium alloy called THE HEAD BLOCK which is supported on rollers on the lower alloy channel. To prevent excessive side movement of these support rollers, a small section of the lower channel is cut out limiting their travel. The rollers are made of an insulating material as it is essential that no electrical contact exists between the head block and the metal frame. It is for this reason that the W shaped spring which retains the head block is insulated from the lower channel by insulating washers. The reason for the free mounting, as has been explained before, is to allow the whole bank of heads to be moved sideways to reproduce the sound from any of the three tracks recorded on each tape. The lateral motion of the head block is controlled by the track selector control.

Contact of the tape on to the tape head is attained by means of a pressure pad mounted above the tape, and in a position over the tape head. The pressure pad consists of a felt pad mounted on a shaped arm which is rivetted to a light spring. The spring is secured to the pressure pad support bar by a 4BA screw, the hole in the spring being slotted to allow adjustment. The damping bars have been introduced to prevent the pad arm from vibrating vertically after being released from contact with the tape.

The Track Selector Control

The track selector control mounted on the control panel provides positive location of any of the three tracks recorded on the tape. Rotary movement of this control is transmitted via a mechanical linkage to a triangular plate mounted on the left hand end of the head block. The holes in the triangular plate are enlarged to allow for fine adjustment.

The Capstan

The capstan is a round bar running the whole length of the instrument and is the means by which the tapes are driven at a constant speed over the tape heads. The bar is ground to very fine limits in diameter and straightened by a special process at the factory so that the speed of all tapes should be the same.

The capstan runs in ball races which are mounted to the frame in special housings, and it is driven at the left hand end by the flywheel. The flywheel in its turn is driven by a belt from the capstan motor, mounted below the frame on the motor mounting board.

Tape Storage Box

This unit is constructed of wood and is supported behind the capstan on blocks screwed to the motor mounting boards. The tape passes through

the box, adjacent tapes being separated by dividers which locate in slots in the back and front of the box. The lid prevents the tapes from rising out of the box when the tape is being played.

Keys

The keys are manufactured from seasoned softwoods which are chosen for their resistance to warpage. The white notes are covered with IVORETTE (Trade Name) and the black notes are formed by plastic mouldings glued on to the wood.

Each key is mounted on a strip of spring steel which has a hole, which locates over a screw on the key mounting bar. A NYLOC nut holds down the spring and provides adjustable tension to each note individually. The front of the key is guided by an oval pin, set in the guide pin bar, which fits in a felt lined hole in the underside of the key. The guide pin can be turned to take up side play in the key which can develop as the felt beds in.

The key also carries two adjusting screws — the front one controlling the pressure pad whilst the rear screw adjusts the pressure on the pinch roller. The keys are correctly set for height above the guide pin bar by the key top stop bar which is an aluminium angle with a self adhesive cellular rubber pad underneath.

SECTION VII

Electronic Features

Reference to the Block Schematic shows the electronic layout of the Mellotron 400. Commencing at the lowest level point of the electronics — the output of the headblock.

The head block consists of 35 magnetic replay heads of the low impedance type (3MH) wired in series, and is connected to the preamplifier by coaxial cable.

The preamplifier type WME LNP provides the necessary equalisation to a slightly modified NARTB characteristic. Equalisation is provided by the tone control located on the control panel. The output of the preamplifier is fed into the line amplifier type WME 289 LAB and thence to a 2 circuit line output jack fitted to the rear of the instrument. The line output provides 3 volts into 5 K ohms where a foot swell pedal is fitted, or 3 volts into 600 ohms without the foot swell pedal.

Both preamplifier and line amplifier are of the plug in type and are located in a metal box which acts as a shield, directly beneath the control panel.

Power Supply

The power unit provides the various voltages needed to operate the electronics of the Mellotron 400.

In this unit type PU4, the mains transformer is tapped at 115V, 220V, and 240V, 50 or 60 Hz. Selection of these voltages is by means of a voltage tapping plug located on the rear of the power unit. The power consumption required is 75 VA.

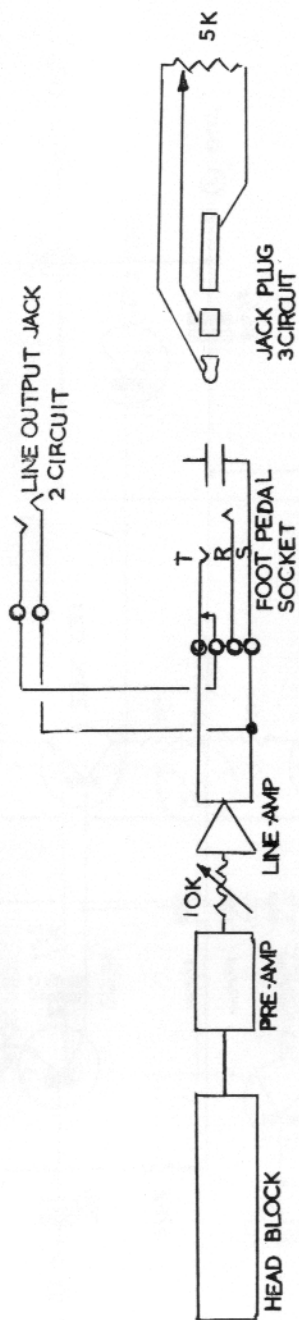

BLOCK DIAGRAM.

LINE AMPLIFIER CIRCUIT WME 289 type LAB

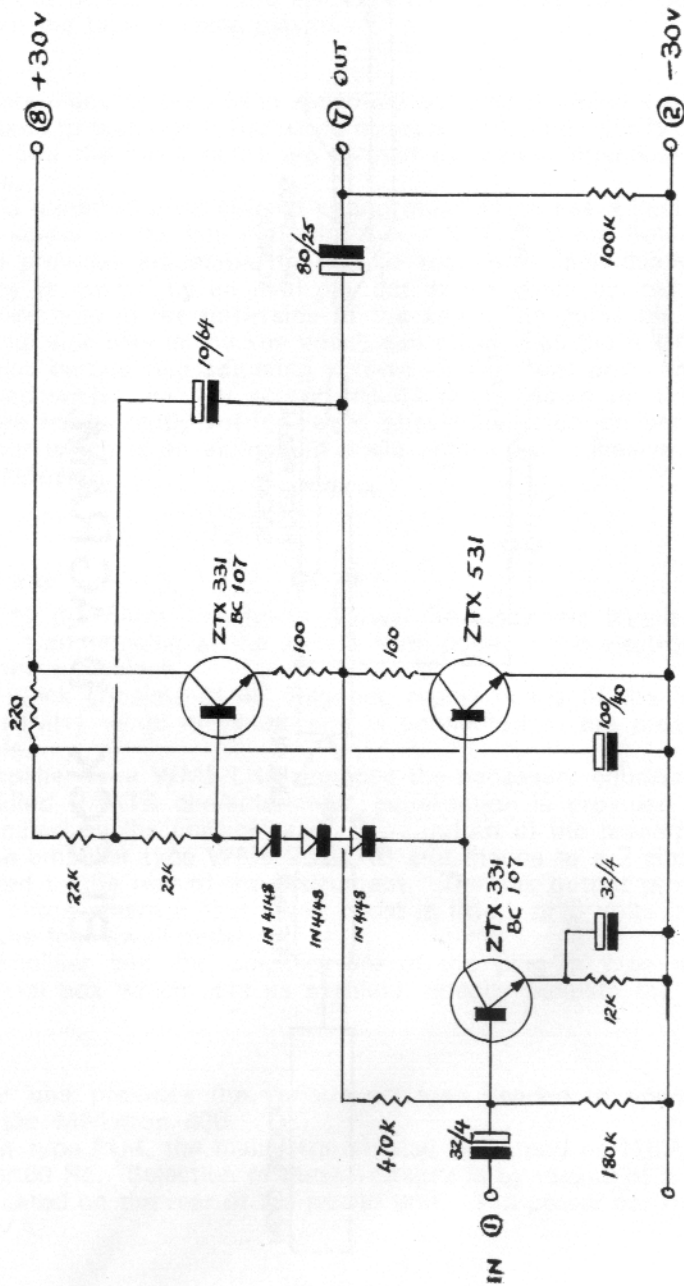

PRE-AMPLIFIER CIRCUIT

WME 290 TYPE LNP

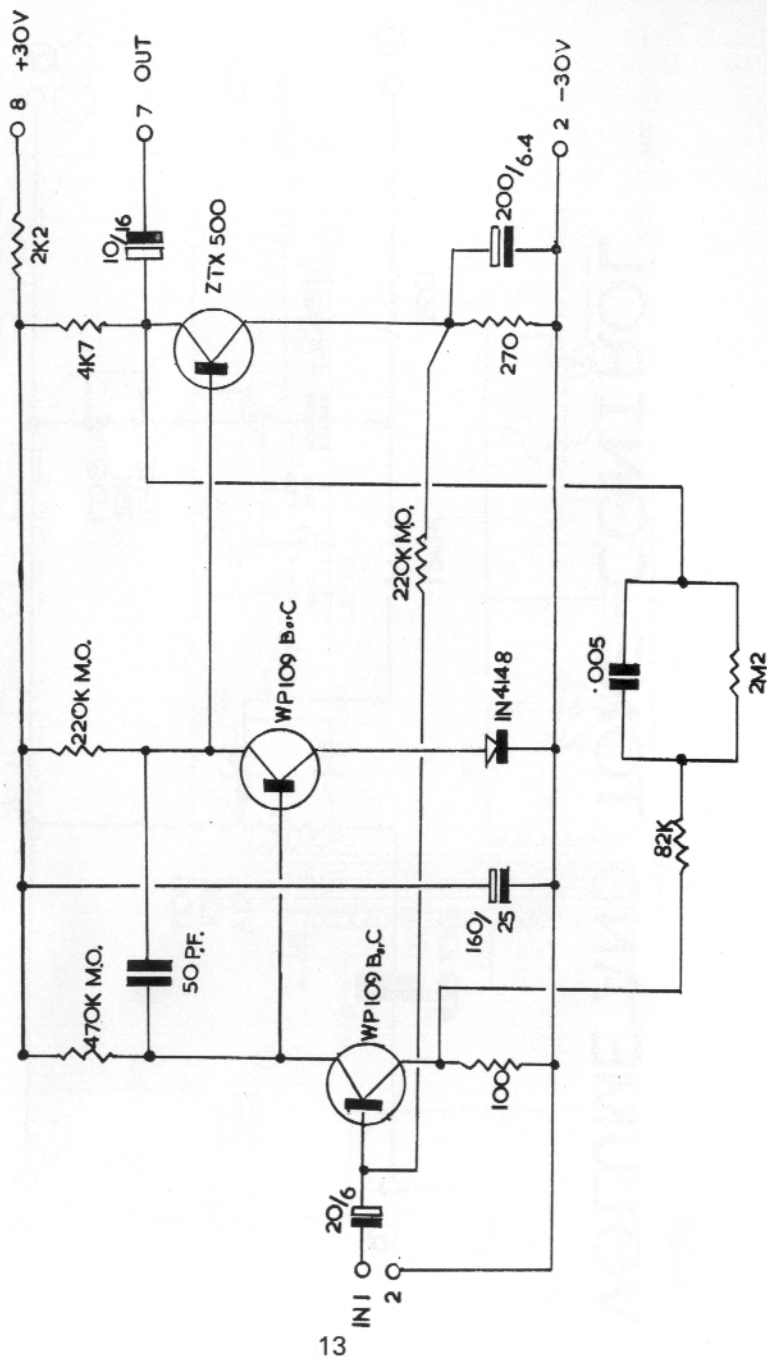

VOLUME AND TONE CONTROL

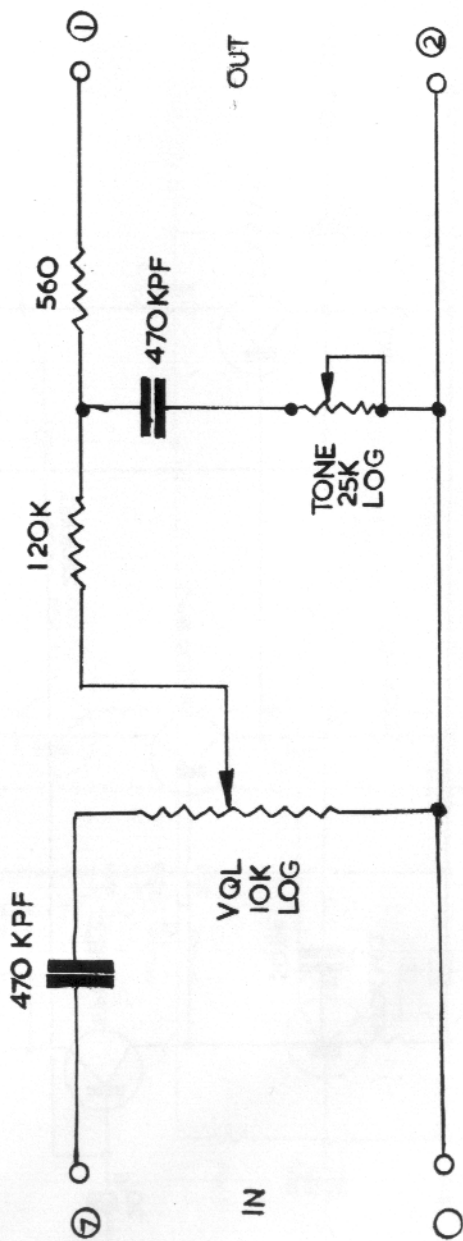

POWER SUPPLY TYPE M400s

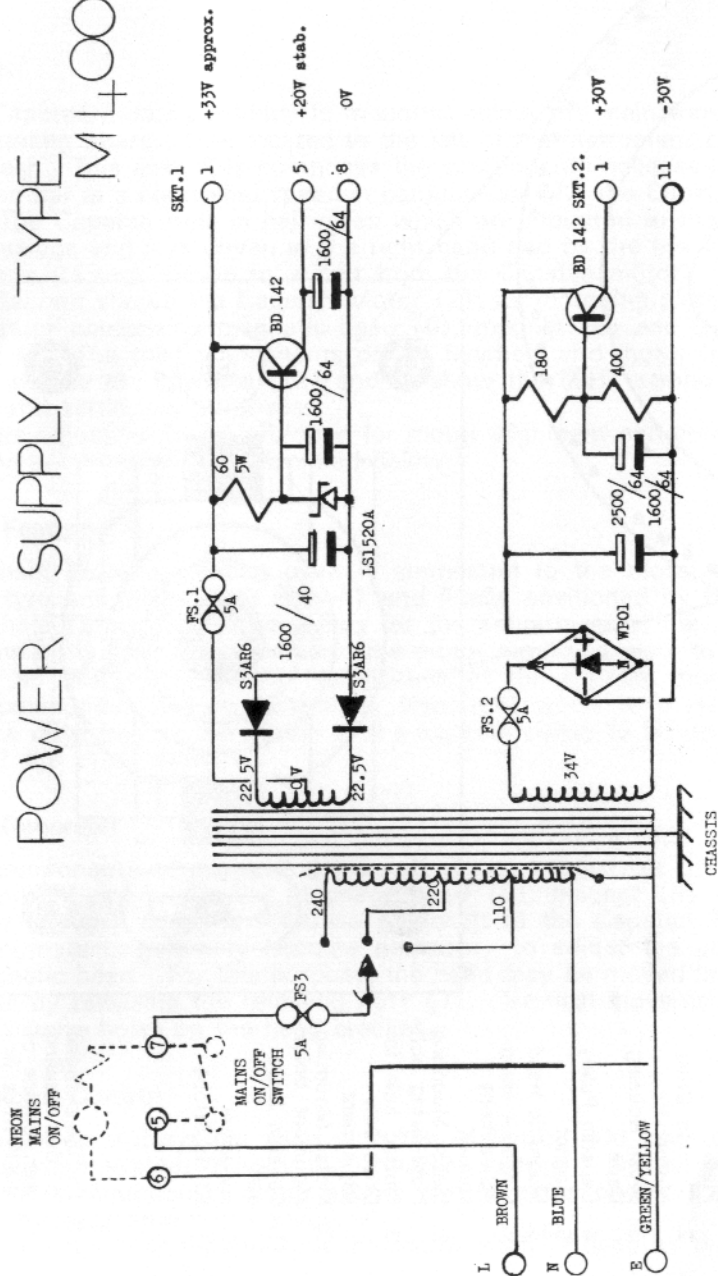

1. Motor Mounting Plate
2. Capstan Drive Motor
3. Brush Housing Caps
4. Capstan Pulley
5. Magnet
6. Magnetic Head
7. Magnetic Head Adjustment screws
8. Motor Mounting Plate fixing bolt
9. Slotted hole for Drive Belt adjustment
10. Motor Mounting alignment bolts
11. Capstan Drive belt
12. Fly-wheel
13. 50 Hz Strobe

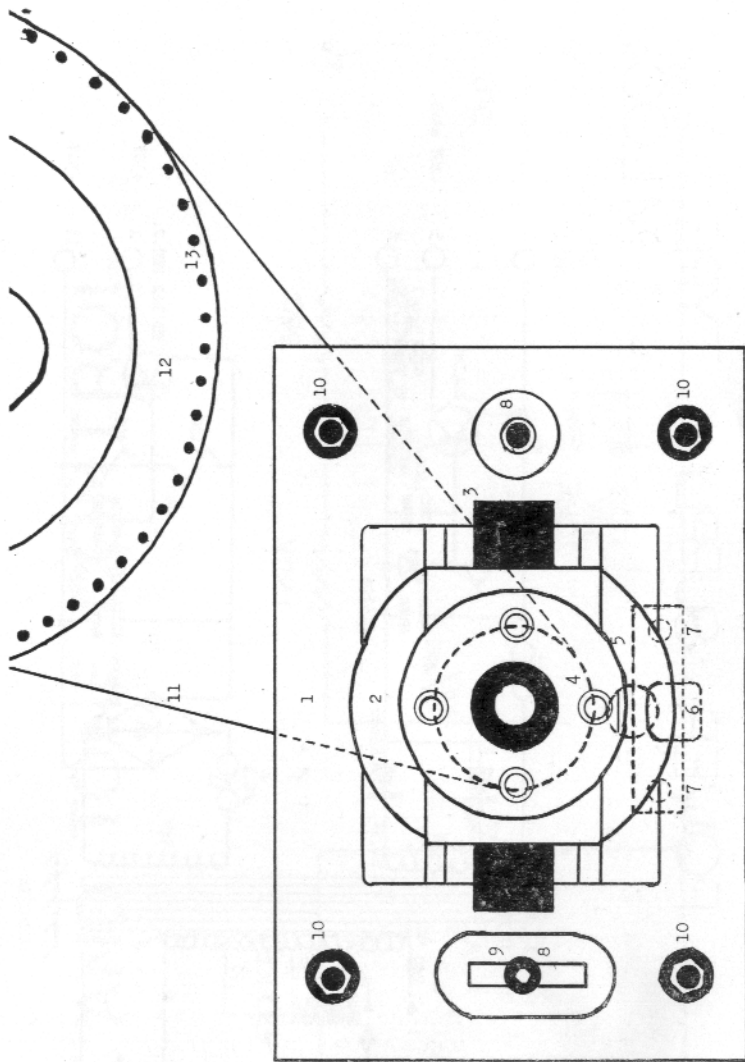

CAPSTAN MOTOR ASSEMBLY

N.B. For the purpose of this drawing the position of the flywheel has been moved

THE CAPSTAN MOTOR ASSEMBLY

Description

The Capstan motor assembly is mounted below the main frame on the motor mounting board. It is located to the left of the instrument as viewed from the rear. This assembly comprises the components necessary to drive the Capstan bar at a controlled speed in conjunction with the Capstan Motor Control. The Capstan runs in ball races which are mounted to the frame in special housings and it is driven at the right hand end by the flywheel. The flywheel is in its turn, driven by a belt from the Capstan motor.

The diagram shows the Capstan Motor (2); its mounting plate (1); the tone generator comprising magnetic head (6); magnet (5) and tone wheel (not shown). The relative positions of the flywheel and motor have been altered to include the flywheel (12) and to show the 50HZ strobe provided for tuning and setting-up purposes.

Various adjustments are provided for motor alignment and correct drive belt tension — these will be described below.

Mounting Features

The main Motor mounting plate is connected to the motor mounting board via two sub-plates (not shown) and finally positioned by bolts (8). A slotted hole (9) is provided to allow for the adjustment of the drive belt tension. The bolts (10) which connect the motor mounting plate to the sub-plates are so designed to allow the attitude of the capstan motor to be correctly positioned. This is particularly important when it is required to position the drive belt on the crown of the capstan pulley to achieve correct stability of the drive system.

The Tone Generator

The components of the tone generator, which are part of the Capstan Motor Control System, are the magnetic head (6); magnet (5) and tone wheel (not shown) which is fitted on the shaft of the Capstan Motor. In certain circumstances, it may become necessary to adjust the positioning of the magnetic head. For this purpose, the head may be moved backwards or forwards by releasing the retaining nuts (7). Vertical movement is provided by oversize holes on the head bracket.

Capstan Motor Control

The pitch control system used with the Mellotron 400 uses the pulse width modulation system to vary the armature voltage. The system is so arranged that a reduction in motor speed, due to extra load, will cause an increase in average armature voltage.

The tone generator mounted on the motor shaft is used as the control

input. The output of the input amplifier is used to reset the ramp generator, the height of the ramp depending on the pitch control setting and the frequency of the input. The slower the motor runs, the greater will be the ramp height. The sample waveform generator supplies a sawtooth waveform which is D.C. restored to the peak amplitude of the ramp. This composite waveform is used to drive the level detection amplifier which gives an output when the input exceeds a certain fixed voltage level. This output is used to operate a high speed switch in such a way as to switch the motor on when the input to the level detection amplifier is in excess of the fixed voltage.

As explained above, when the motor speed reduces, the ramp height increases, thus switching the motor on for a larger proportion of each cycle of sample waveform. The loop gain of the system depends on the amplitude of the sample sawtooth and too small an amplitude will cause 'hunting' (violent over correction). It is, therefore, necessary to obtain a compromise between satisfactory sensitivity and excessive gain.

CAPSTAN MOTOR CONTROL — TYPE CMC 4s & CMC 10

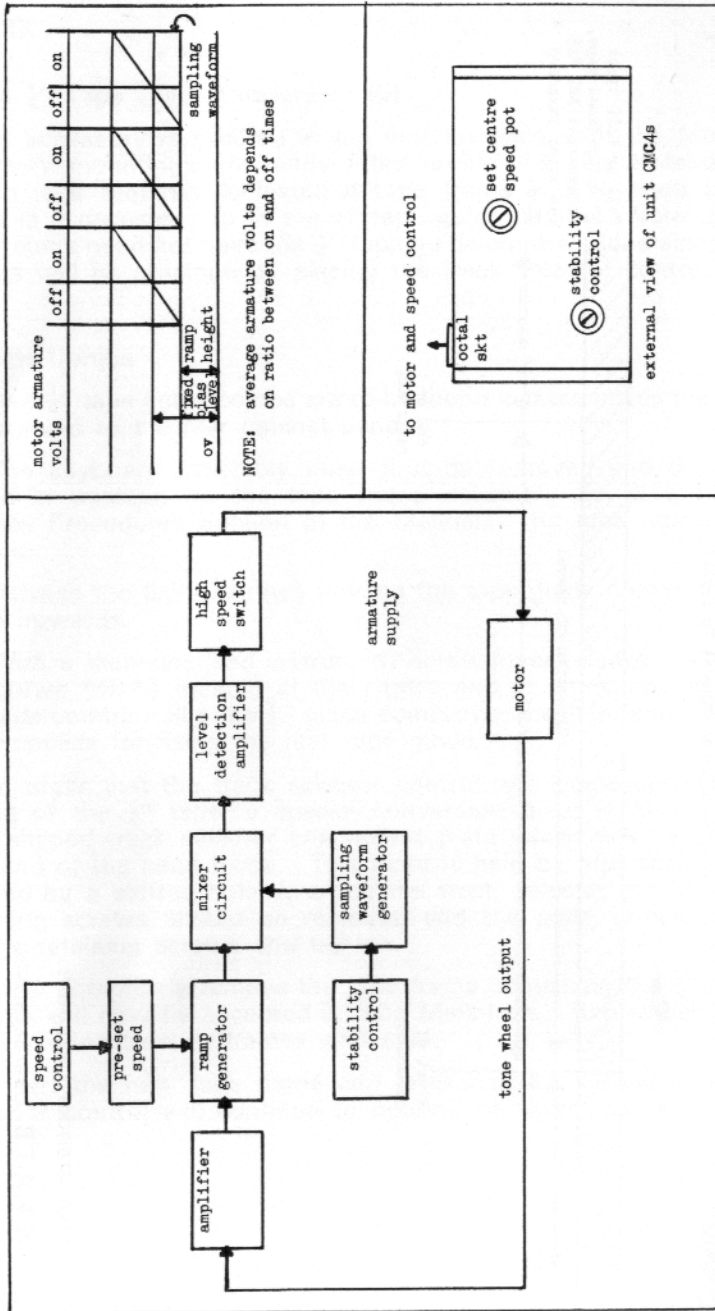

METHOD OF RECORDING FOR THE 'MELLOTRON 400'

8 to 9 seconds playing time at $7\frac{1}{2}$ i.p.s.

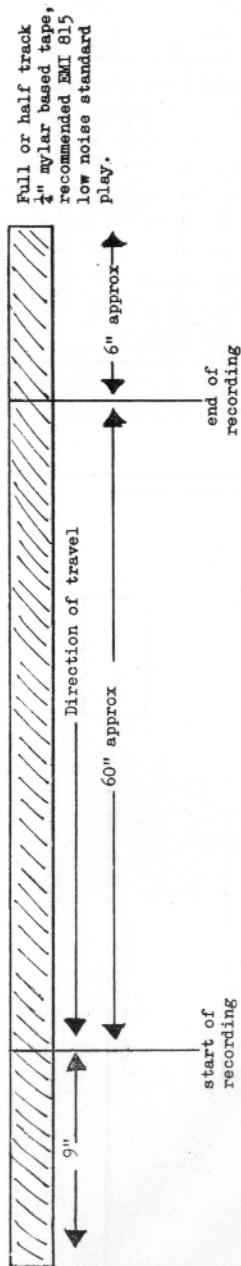

1. Use standard azimuth
2. N.A.R.T.B. characteristic
3. Maximum recording level as operating level on Ampex test tape
4. Use centre position only of tape reel

Located in screening box under control panel

SECTION IX

Fitting The $\frac{1}{4}$ " Tape Guide Conversion Kit

If this accessory is ordered in the first instance with the Mellotron all the necessary mountings are ready fitted during the final assembly stage. Only when it is required to install a tape frame with $\frac{1}{4}$ " two track tape recordings is it necessary to fit the $\frac{1}{4}$ " tape guide combs. Note that $\frac{1}{4}$ " full track recordings need not have the $\frac{1}{4}$ " tape guide combs added since satisfactory results will be obtained by placing the track selector control on the B setting.

To Fit Guide Combs

The two $\frac{1}{4}$ " tape guide combs are to be found located inside the Mellotron cabinet screwed to the rear cabinet panel.

1. The keyboard assembly must first be removed and the rear tape bar placed in position on the tape frame assembly as described in the Maintenance Procedures Section of the Manual. The tape frame need not be removed.

2. Release the fixing screws holding the tape guide combs and lift the first comb upwards.

3. With a demagnetised instrument screwdriver release the three protruding screws (4BA) located at the centre and at either end of the front $\frac{3}{8}$ " tape guide combs. Slip the $\frac{1}{4}$ " guide comb over these screws and tighten. The same applies for fixing the rear tape guide.

4. In order that the track selector control will locate correctly on the two tracks of the $\frac{1}{4}$ " tape, a special conversion plate is fitted on to the triangular shaped track selector adjustment plate which will be seen at the left hand end of the head block. This plate is held by two screws and can be identified by a slotted hole in which the track selector pin locates. The two retaining screws should be removed and the plate turned over 180° . Replace the retaining screws and tighten.

5. Now completely remove the tape frame containing the $\frac{3}{8}$ " tape since only $\frac{1}{4}$ " tape will now be accepted in the Mellotron. Remember to protect the recordings and treat all frames with care.

6. Insert the new tape frame and re-assemble. Please note that the track selector control will continue to operate on three tracks but one will be silent.

MAINTENANCE PROCEDURES

This section gives in detail all the standard adjustments and procedures called for in other sections.

PLEASE NOTE: All tools used must be DEMAGNETISED.

A. KEY ADJUSTMENT

1) The depth of movement of the keys is controlled by the aluminium bar supported about 8" from the front of the keyboard on top of the keys. The height of this bar is adjusted at the factory to give a maximum depth of key movement of $\frac{3}{16}$ ".

2) KEY TENSION (or touch)

The key tension is determined by the 2BA Nyloc Nuts, retaining the key leaf springs at the rear of the keys. By turning each nut clockwise the key tension will increase and the key will rise. In manufacture, keys are adjusted by the above method until the key rises and just comes into contact with the bar above the keys. When all the keys are just touching the underside of the bar, a further $\frac{1}{4}$ turn is applied. This is standard key adjustment.

3) PRESSURE PAD ADJUSTMENT

Pressure pad adjustment is achieved by turning the 4BA screws protruding from the top of the keys nearest the front of the instrument — hereinafter called the PAD ADJUSTMENT SCREW. Assume that the pad is not pushing the tape into contact with the reproducing head at all. Clockwise movement of the pad adjustment screw will cause the pad to move down under key pressure and with correct adjustment allow the tape to play. The pad adjustment screw should be turned gently clockwise until sound is **just** heard — at this point ONE further complete turn should be applied.

4) PINCHROLLER ADJUSTMENT

This adjustment is effected by the second 4BA screw nearest the rear of the key.

Correct adjustment of the pinchroller is a full 2 turns beyond stall.

To achieve this setting turn the pinchroller adjustment screw anti-clockwise until the point is reached where the tape slows down and just stops driving. At this point the screw should be turned 2 full turns clockwise. This is the correct adjustment.

B. TRACK SELECTOR ADJUSTMENT

Fine adjustment of the track selector mechanism is afforded by means of slotted holes on the track selector plate located on the left end of the head block.

1) Select track B on the control panel.

- 2) Release the two screws on the track selector plate.
- 3) Depress a key and move the headblock laterally by hand until the strongest signal is achieved.
- 4) Tighten the screws on the track selector plate.

C. PRESSURE PADS

The purpose of this adjustment is to equalize the response on all three tracks of the tape. Should it be found that the response of tracks A and B are clear but that of track C is muffled, proceed as follows:—

- 1) Remove lid of cabinet.
- 2) Remove key top stop bar and key affected by undoing the 2BA Nyloc nut at the rear of the key.
- 3) Remove the 4BA screw holding the pressure pad arm and lift out the pad.
- 4) Viewing the pad end of the arm, it can be seen that if track C is weak in H.F. response due to too little pad pressure, we must increase this pressure by twisting the pad so that the left side comes lower. Care must be taken not to twist the spring which holds the pad arm.
- 5) Refit the pad arm, making sure that the pad sits exactly over the tape and square on the head.
- 6) Re-assemble and test. Make sure that improving track C has not worsened track A. If so, you have gone too far. Remove and try again.
- 7) If the response is poor on all tracks, the pad may not be pressing directly on to the gap area and must be checked for position over the head. Adjustment is provided for this purpose.

The pad should come down flat on to the head so check that there is no tendency to "toe in". This means that the tip of the pad is lower than the inner side. Bend the pad so that it is flat. If the response is still poor, move the pad forward or backwards. This adjustment may require a certain amount of trial and error.

D. CAPSTAN MOTOR CONTROL

This unit is situated to the right of the power supply as viewed from the rear of the unit.

Setting Up Instructions

- 1) Set the pitch control knob to the centre setting.
- 2) Adjust "Set Centre Speed" control to make capstan turn at 182 r.p.m. A strobe is provided on the flywheel for this purpose.
- 3) Turn pitch control knob full anti-clockwise.
- 4) Turn stability control gently anti-clockwise until the system starts to 'hunt'—('hunting' will be heard as violent continuous speed changes when playing a tape).
- 5) Turn stability control clockwise until hunting ceases and check that this condition cannot be restarted by placing a sudden load on the flywheel.

Replacing a Tape

A tape may be replaced with the tape frame in or out of the unit. There follows a description of how this is achieved with the tape frame in the unit.

- 1) Remove cabinet top lid and front panel.
- 2) Remove key end blocks by lifting upwards.
- 3) Remove keyboard assembly by releasing four red finger screws and lifting the assembly upwards clear of the unit.
- 4) Remove the tape storage box lid.
- 5) Release the tape to be replaced by undoing the appropriate screws on the rear tape clamp bar.
- 6) Pull the tape out of its position in the storage loops and release the other end of the tape.

The replacement tape will be supplied with its start outermost and this should be placed under the clamp on the rear clamp bar.

Proceed As Follows:—

- 1) Feed the remaining tape on the spool into the tape storage box and remove the tape from the spool.
- 2) The end of the tape should then be placed under the clamp on the front clamp bar.
- 3) Using service tool 'K' push the tape down on either side of the support roller so that it goes in two loops between the separators. Continue pushing the tape down until the tongs are fully down, then leaving them in place and feeling upwards between the two separators, catch the two loops on the first and second fingers. Pull down the loops on the first and second fingers.
- 4) Take the spring loaded pulley assembly and break open one side to give access to the rollers.
- 5) Lift the tape loops on to the appropriate rollers and snap shut the assembly.
- 6) Check that the height of the tape loop is correct, if not adjust from the front clamp bar.

The tape must now be positioned so that its start is accurately placed over the re-producing head.

Proceed As Follows:—

- 1) Replace the tape storage box lid and the keyboard assembly.
- 2) Switch on the instrument and tap the key in question.
- 3) If a delayed sound is heard, release the screws on the rear clamp bar and slowly pull the tape through until the attack of the instrument recorded on the tape responds on tapping the key.
- 4) Check all tracks in a similar manner.
- 5) Tighten clamp bar screws and replace end blocks and cabinet panels.

Replacing a set of tapes is the same as for a single tape.

STRIPPING PROCEDURES

(a) The Tape Frame

- 1) Remove the cabinet lid by holding from the rear and lifting upwards.
- 2) Unclip the left and right key end blocks.
- 3) Release the four RED knurled finger screws which hold the keyboard assembly. Lift upwards clear of the instrument. Place on a clean surface.
- 4) Remove the aluminium tape storage box lid located behind the capstan bar.
- 5) Release the two YELLOW knurled finger screws which hold the rear tape clamp bar in position.
- 6) Lift the bar upward and toward you until the tapes are in a vertical position just behind the front tape guides.
- 7) Slowly lower the bar into a position behind the front tape guides. Locating pins at each end of the clamp bar should then be rested at the points provided — coloured YELLOW.
- 8) Release the two BLACK knurled finger screws. Lift the complete tape frame slowly upwards until completely clear of the unit.
- 9) Place in the tape frame box to avoid damage.

Fitting the tape frame is the reverse of the above procedure. All knurled finger screws must be secure to avoid assemblies coming out of adjustment.

(b) The Control Panel (Access to pre-amplifier and line amplifier)

- 1) Remove top cabinet lid and left hand key end block.
- 2) Remove the two 2BA screws at the rear of the control panel.
- 3) Remove the headblock coaxial plug.
- 4) Lift the panel assembly upwards and turn over to show the metal cover of the hum shield.
- 5) Access to the pre-amplifier and line amplifier circuit cards is gained by removal of the four retaining screws.

RE-ASSEMBLY IS THE REVERSE OF THE ABOVE.

Important Note

Before replacing the headblock coaxial plug, it is important that the input to the pre-amplifier be shorted across. The head block coaxial plug should then be fitted immediately. On no account should this be done with the instrument switched on. The result of so doing will cause the heads to become magnetised with the risk of partially erasing the signal from any tape that is played.

C. KEYS

First the top stop bar is removed by undoing the two 2BA screws. This will allow the keys to spring upwards off the front guide pins. Slide service tool 'M' under the keys just behind the front guide pins, taking care not to catch the tapes. Using the bar, lift the keys sufficiently to allow the bar to be rested on top of the key stop pillars. This will relieve the strain on the key mounting bar and enable the 2BA cap screws to be removed safely. Use service tool 'J'.

Grasping the bar and the end keys, it will be found possible to lift all the keys together. Place them down on a clean surface to avoid dirtying the pinchrollers.

Pad Assembly

The pad assembly can now be removed by releasing the 2BA screws holding it, and lifting clear. Care should be taken not to bend any of the pads when placing the assembly on a clean surface.

MAINTENANCE PROCEDURES — FAULT FINDING

No sound when any key depressed	Control panel light out	<ul style="list-style-type: none"> —mains plug not fitted or faulty —panel switch faulty 	<ul style="list-style-type: none"> —check —check and replace if necessary —replace. If it blows again remove all outputs from P.U. If O.K. replace until culprit revealed
	Control panel light on	<ul style="list-style-type: none"> —mains fuse blown —power unit faulty —Capstan not turning —line out jack faulty —pre-amp/line amp faulty —Capstan not tuning —keyboard assembly not fitted correctly —drive belt slipping badly 	<ul style="list-style-type: none"> —If mains fuse blows with all outputs removed, power unit requires investigation —Capstan motor u/s —CMC not working —check for dry joint or bad contact —check and replace —check motor running. If not, check CMC and P.U. —check four red screws and pressure pad assembly for damage —re-adjust
no sound when a particular key is pressed	—on all tracks	<ul style="list-style-type: none"> —pad badly tipped or strained through overadjustment —tape erased —tape not returning 	<ul style="list-style-type: none"> —re-adjust or replace pad —very unusual but replace affected tape —check for overadjusted pinchrollers or dirt in tape guides
	—on one track	<ul style="list-style-type: none"> —felt pressure pad missing —insufficient pad or pinchroller pressure —seized pinchroller —tape jammed 	<ul style="list-style-type: none"> —replace pad —adjust —replace —remove keyboard and ascertain cause
Distorted sound	—Preamplifier/Line amplifier running at low voltage	—check	—check
	—Fault on line amplifier or preamplifier	—check	—check jack plug and socket
—Bad connection at line out	—Bad matching between Mellotron and amplifier being used	—check specification of Mellotron and amplifier	—check specification of Mellotron and amplifier

Bad sound

—on one key

—on all keys

- Pinchrollers not free running —replace
- incorrect pad and pinchroller adjustment —re-adjust
- tape damaged —replace
- bottom roller assembly obstructing tape movement —clean thoroughly
- dirt on head —clean thoroughly
- keyboard assembly not fitted correctly —check four red screws
- CMC unstable —check adjustments
- Capstan belt tension insufficient —adjust
- Capstan drive belt faulty —replace
- dirty capstan pulley causing high speed flutter —clean thoroughly
- headblock not correctly seated —check position on rollers
- capstan turning too fast sounds un-natural —re-adjust CMC
- check magnetic head on motor
- check 2N3055 transistor on CMC

BAD SOUND OF VARIOUS TYPES

Background Hiss When Tape Is Played

Usually due to two causes. The first contributes a moderate amount of hiss and is called modulation noise on the tape. This is a function of tape recording continuous tones and there is no cure.

A severe hiss is most likely caused by a magnetised head block. If this is the case, the head block must be removed and demagnetised immediately. If this is delayed, permanent damage to the tapes will result.

Hum and Whine

Probably due to the following:—

1. Earth loop caused by both amplifier and Mellotron being earthed. Cure by disconnecting earth on Mellotron.
2. 'M' springs retaining head block touching main frame. Check that these are correctly positioned. The head block must be completely isolated from the main frame.
3. Pickup of Television Carrier is another possible cause of hum. The reason for this is the very high impedance of the head block.

Zip

This noise is caused by the returning tape, after being played, passing too close to the replay head. Check the pressure pad settings and also check the head block is seated correctly and not tipped.

Wow and Flutter

Probably due to the stability controls on the CMC being incorrectly set. Re-adjust as described in the appropriate section of this manual. If not, the capstan drive belt should be checked to ensure that it is not touching the side of the capstan pulley or the side of the flywheel. Adjustments are provided on the motor mounting plate for re-positioning the attitude of the motor to correct this.

Other Causes

1. Damaged tape due to creasing, partial erasure, foreign matter or liquid deposited on the tape.
2. Capstan motor imbalance, brush contact or commutator faults.
3. High powered morse transmissions affecting CMC circuitry. This is a very rare occurrence but has happened.
4. Damage to main frame probably due to instrument being dropped. The effect of this will be apparent if it is found impossible to set the pinchrollers and pressure pads. This is normally a fault that can be rectified only under factory conditions.

SECTION XI — ROUTINE MAINTENANCE

REPLAY HEADS

(1) Cleaning

It is recommended that the replay heads are cleaned at least every 3 - 6 months depending on the amount of use of the instrument.

Proceed As Follows:—

Expose the heads as if removing the tape frame. Using a smooth, clean cloth with a little Methylated Spirit or Carbon Tetrachloride clean each head methodically and polish immediately with a clean portion of the cloth.

(2) Demagnetising

The heads should be demagnetised once every 12 months or on fitting a replacement head block assembly, when a head block has been tested using a meter or a head has been in contact with a magnetised instrument.

Proceed As Follows:—

- (a) Expose the head block as if removing the tape frame.
- (b) Release the retaining springs at four points on the head block.
- (c) Disconnect the output lead of the head block.
- (d) Using a demagnetiser carefully demagnetise the whole head block taking care not to switch the demagnetiser off in the vicinity of the head block. Most demagnetiser manufacturers give detailed instructions of this operation which should be followed.

REMEMBER A MAGNETISED HEAD CAN PARTIALLY ERASE A RECORDING

Pinchrollers

Pinchrollers should be cleaned and checked approximately every 6 months dependant on the amount of use. Each pinchroller should be cleaned with Carbon Tetrachloride.

Proceed As Follows:—

- (a) Remove keyboard assembly by releasing the four red finger screws.
- (b) Turn the assembly over and expose the pinchrollers.
- (c) First check that each pinchroller moves freely. Any stiff wheels should be replaced. **N.B.** The pinchroller assembly is easily removable by first removing the key top stop bar and the 2BA Nyloc nut on the key bar.

Removal of the two wood screws which hold the pinchroller assembly onto the underside of the key will release this assembly. Reassembly of the pinchroller is the reverse of the above procedure.

- (d) Clean each pinchroller carefully.
- (e) Replace the keyboard assembly.
- (f) Any key which has had a pinchroller replaced should be readjusted as described in this section.

Pressure Pads

It is necessary from time to time to inspect the pressure pads to ensure that the felts have not collected dirt which may impair their performance. Pick off any fluff which may have accumulated and lightly dab with dry cleaning solvent.

The pressure pads must be treated with the utmost care in order not to disturb their settings.

CAPSTAN MOTOR ASSEMBLY MAINTENANCE

The correct maintenance of the capstan motor is of extreme importance to ensure consistent reliability of the servo capstan drive system.

The condition of the commutator and brushes should be checked from time to time and maintenance should consist of the following:—

1. Thoroughly clean the commutator with carbon tetrachloride.
2. Remove brushes one at a time noting exactly how and in what position they were removed. Clean thoroughly with CTC and replace as removed.
3. Brushes showing signs of deterioration should be replaced and the motor run continuously for 48 hours to allow for bedding-in. After bedding-in remove brushes and clean. Also clean commutator thoroughly.
4. Check cleanliness of capstan pulley. Dirt deposits may tend to cause a high speed flutter effect. Clean thoroughly with CTC.
5. Clean magnetic head, magnet and tone wheel ensuring that the position of the magnetic head is as near the tone wheel as possible without it actually contacting the head.

U.K. ADDRESS

DALLAS

DALLAS HOUSE

CLIFTON STREET

LONDON EC2P 2JR

Telephone: 01-247 9981

Telegrams: HARMONIOUS LONDON EC2P 2JR

Telex: 886137

U.S.A. ADDRESS

DALLAS MUSIC INDUSTRIES (U.S.A.) LTD.

301 ISLAND ROAD, MAHWAH

NJ 07430(201) DA 7-6300-1-2

GERMANY

DALLAS ARBITER G.m.b.H.

2373 SCHACHT-AUDORF

POST FACH 26

W. GERMANY

AUSTRIA

DALLAS ARBITER G.m.b.H.

FAVORITENSTRASSE 70,

1040 VIENNA 4

AUSTRIA