



# WERSI

User's Guide  
EX 20  
M.I.D.I. EXPANDER  
(MK 1 M.I.D.I.)

AM 3181

First Edition

# THE DIGITAL SOUND SENSATION

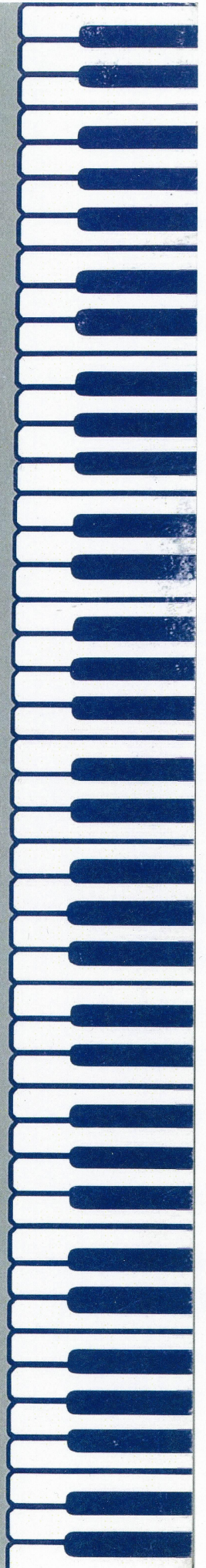

# User's Guide EX 20 M.I.D.I. EXPANDER

(MK 1 M.I.D.I.)

AM 3181

First Edition

(This manual is also an easy-to-use guide for basic MIDI configurations using the MK 1)

## **NOTE ON DMS INSTRUMENTS SOLD IN THE U.S.A.**

Internally, DMS Instruments generate signals in the radio frequency spectrum. If the instrument is installed in the immediate proximity of some types of audio or video devices (within ten feet) interference may occur.

Federal Communications Commission (FCC) Rules and Regulations, Part 15, Subpart J, establishes design and manufacturing standards that will provide a reasonable level of protection against the possibility that two electronic devices, operating simultaneously, might interfere with each other.

Compliance with the standards established by the FCC does not guarantee that interference will be eliminated. If your instrument is suspected of causing interference with other electronic devices, verification can be made by turning your instrument on and off. If the inter-

ference continues when your instrument is off, the instrument is not the source of the interference. If your instrument does indeed appear to be the source of the interference, please ask for suggestions or seek corrective measures by contacting:

WERSI—Service Department  
P.O. Box 5318  
1720 Hempstead Road  
Lancaster, PA 17601  
Telephone: (717) 295-9471

If for any reason you should need additional information relating to radio or TV interference, you may find a booklet prepared by the FCC helpful: "How To Identify and Resolve Radio-TV Interference Problems." This booklet, stock number 004-000-00345-4, is available from the U.S. Government Printing Office, Washington, DC 20404.



## TABLE OF CONTENTS

A. PREFACE .....	4
B. PREPARATION .....	5
C. USING THE MIDI EXPANDER EX 20 .....	8
1. The MIDI Concept of the EX 20 .....	8
2. Channel Selection .....	9
3. Selecting MIDI Mode .....	12
4. Setting the Range of the Voice Information .....	14
5. Registration of the Internal Keyboards .....	14
D. MIDI Direct Mode .....	16
E. Checklist for Problems .....	17
F. Changing Fuses .....	19
G. Appendix .....	20

## A. PREFACE

Congratulations, you've just expanded your keyboard instrument and it's capabilities into a new dimension of sound and features.

With the EX 20 MIDI Expander you have added virtually eight additional keyboards to your present instrument which can be controlled through MIDI from your present instrument (or from a sequencer or a computer). If you are experiencing MIDI for the first time, just take it easy and even more important, one step at a time.

In this manual we will only refer to the EX 20 exclusive set ups and initial information. Please realize that an EX 20 represents WERSI's latest Digital Synthesizer MIDI and all of its features and sounds. That is why you'll find the MIDI User's Manual included. They will become your main reference guide.

Now let's get started! As a final suggestion, if something does not operate immediately, there's no magic involved, just probably another switch to turn on or off.

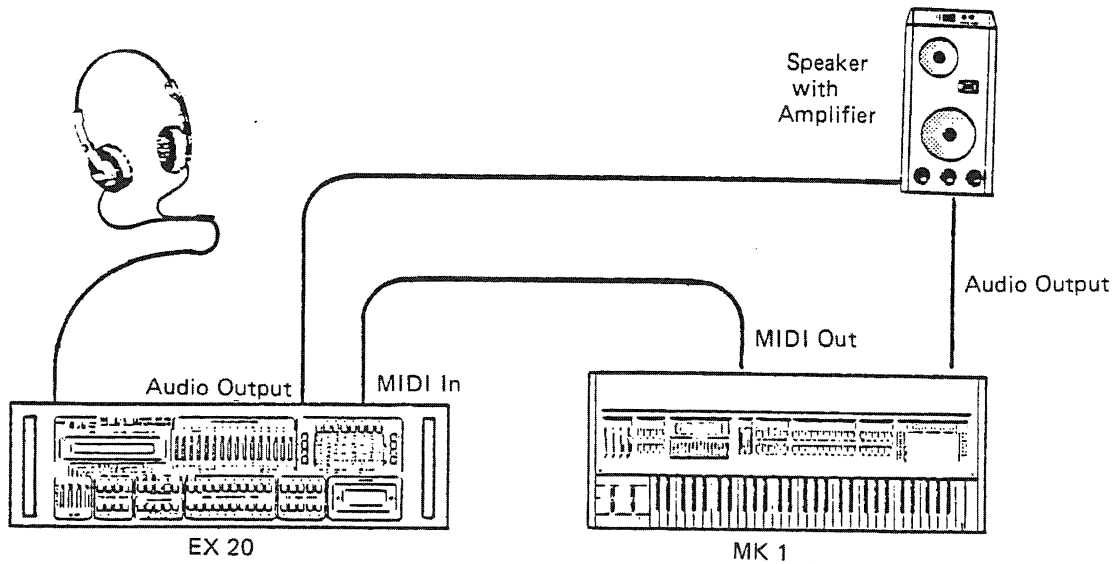

## B. PREPARATION

Setting up the EX 20 MIDI Configuration with a MIDI Keyboard and/or a MIDI Organ.

### 1. MIDI HOOK-UP

Connect the 5 pole DIN Connector Cable from the MIDI Out jack of the organ or keyboard to the MIDI In jack on the EX 20.

### 2. LOW-HIGH OUTPUT HOOK-UP

There are two outputs on the EX 20 for use with a stereo amplifier, mixer, or active speakers.

The "High/Low" slider switch, located on the rear panel of the EX 20, allows switching from high to low. If the maximum output level of the EX 20 is too strong for the receiving unit, switch to low. (Also see the chapter on "Preparations" in the MK 1 User's Guide.)

If the EX 20 is connected to a WERSI DX series or Helios generation instrument self-contained amplifiers and speakers, then the audio signals of the EX 20 can be fed into the cassette input of that particular unit. (5 pole DIN cassette input jack of the instrument.)

### 3. POWER SUPPLY

Before you can start playing your new EX 20 Expander, you will need to make the following connections. **FOR YOUR OWN SAFETY, PLEASE PAY CLOSE ATTENTION TO THE FOLLOWING INSTRUCTIONS:**

**AC CONNECTOR – Check Voltage Rate:** Factory assembled instruments have the voltage selector set to the prevailing line voltage and a fuse with the appropriate rating is inserted. (The voltage selector is also the fuse holder box.) Check the voltage selector and change it and the fuse, if necessary.

Note that the arrow on the selector housing must point towards the line voltage selected.

Insert the AC line cord into the panel plug on the EX 20, as well as into a grounded AC outlet.

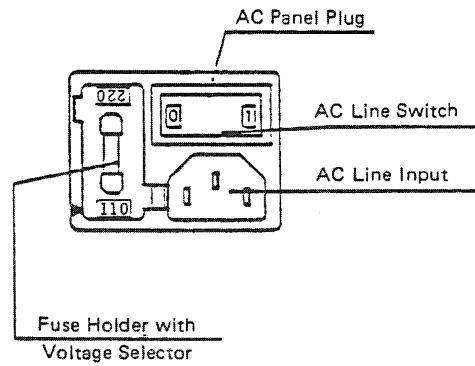

How to change fuses is covered in Chapter F.

### WARNING

**UNPLUG THE LINE CORD** before changing the line voltage selector or the fuse. The components behind the AC panel carry hazardous voltage. Never plug in the line cord without the AC panel securely fastened to the cabinet. Never attempt to inspect or work in the areas of the AC panel plug or AC transformer without first unplugging the AC line cord from the outlet.

If you transport your EX 20, cold weather can cause condensation on the electrical circuitry. Please wait a while until the instrument has adjusted to room temperature.

4. OTHER HOOK-UP POSSIBILITIES are described in the MK 1 User's Guide in the "Preparations" chapter.

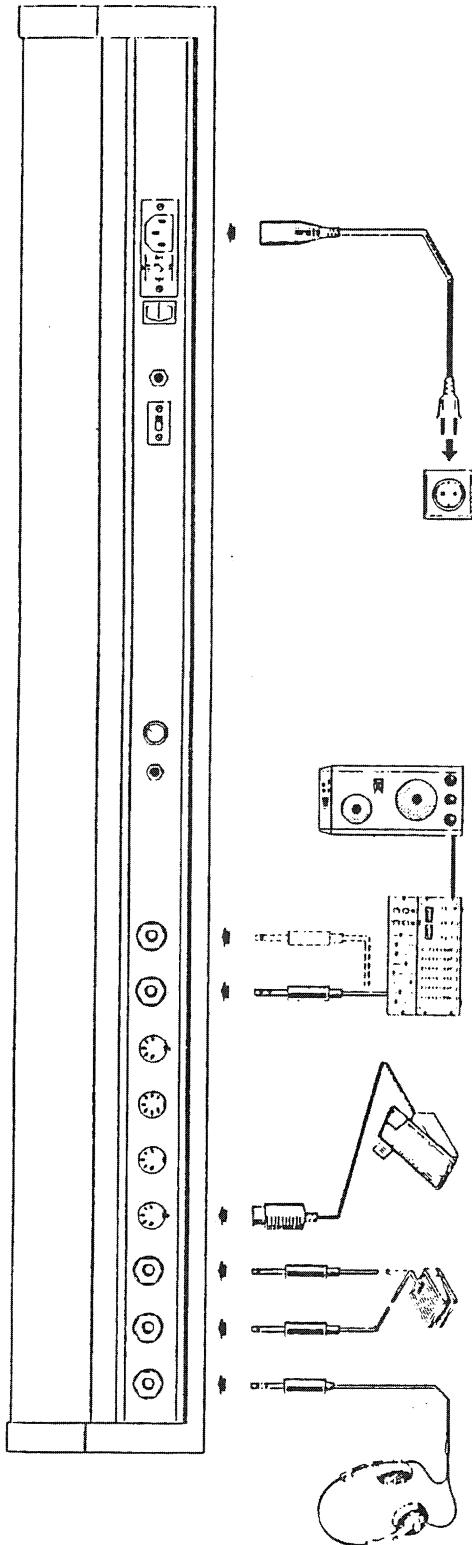

# WERSI MIDI EXPANDER EX 20

**Achtung:**  
Vor Zusammenbau  
Abdeckhaube  
abheben!  
WERSI elektronic

Mode  Intern

Headphone  Footswitch 1  Footswitch 2

Vol. Contr.

MIDI IN  MIDI THRU  MIDI OUT

Stems/L  Mono/R

Output Level High  Low

Made in Germany

**Caution:**  
Unplug the cord  
before removing  
cover.

WERSI elektronic  
Model EX 20  
30 W 50/60 Hz  
110 V : 110 V A  
220 V : 115 V A  
Made in Germany



## C. USING THE MIDI-EXPANDER EX 20

The MIDI concept of the EX 20 is the same as the MK 1. Therefore read the "MIDI Level" chapter in the MK 1 User's Guide.

Through the use of the EX 20 you will expand your MIDI equipped organ or keyboard with all the sounds of the MK 1 Synthesizer. These sounds are limitless through the use of MK 1 cartridges.

### 1. THE MIDI CONCEPT OF THE EX 20

In the introduction to the MK 1 and MIDI you are exposed to the 8 internal manuals of the MK 1. These are of greatest importance in understanding the MIDI specifications of the MK 1. These internal manuals are also found on the EX 20, except they are referred to as keyboards.

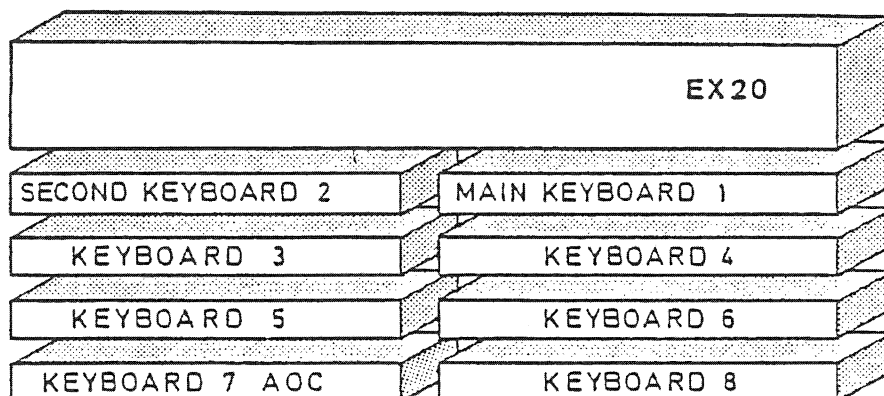

The following chart shows the corresponding names between the MK 1 and EX 20 keyboards:

MK 1	EX 20
Manual Right 1	MAIN KEYBOARD 1
Manual Left 2	SECOND KEYBOARD 2
Manual Pedal 3	KEYBOARD 3
Manual Double Right 4	KEYBOARD 4
Manual Double Left 5	KEYBOARD 5
Manual External 6	KEYBOARD 6
Manual AOC 7	KEYBOARD 7
Manual Double Pedal 8	KEYBOARD 8

The concept of 8 internal keyboards allows you to control the EX 20 as you would if you were playing 8 polyphonic synthesizers when the EX 20 is in the "OMNI OFF-POLY MODE".

This means that as a MIDI receiver, the EX 20 provides you with 8 different sound programs simultaneously containing up to four components each. These 8 internal manuals can be controlled through connected MIDI keyboards or organs. Of course, to do this, the EX 20 and the controller keyboard need to be transmitting and receiving on the same MIDI channel.

## 2. CHANNEL SELECTION

All 8 EX 20 Keyboards (remember these are the 8 Internal Manuals of the MK 1) can be freely assigned to a MIDI receiving channel. For example, if you are playing on an organ which is sending MIDI for the Upper keyboard on Channel 1, Lower keyboard on Channel 2, and Pedal on Channel 3, then you will assign an internal keyboard to each one of the channels mentioned above. A logical progression for keyboard selection would be:

- MAIN KEYBOARD 1
- SECOND KEYBOARD 2
- KEYBOARD 7 (on the MK 1 AOC 7)

This is a good selection for this type of configuration because you can now control the volumes for all 3 internal keyboards on the EX 20. Each one of these particular channels has its own individual volume control on the EX 20, making it easy to balance volume settings.

**NOTE: REFER TO APPENDIX FOR WERSI DMS INSTRUMENT CHANNEL ASSIGNMENT AND TRANSFER CODE INFORMATION.**

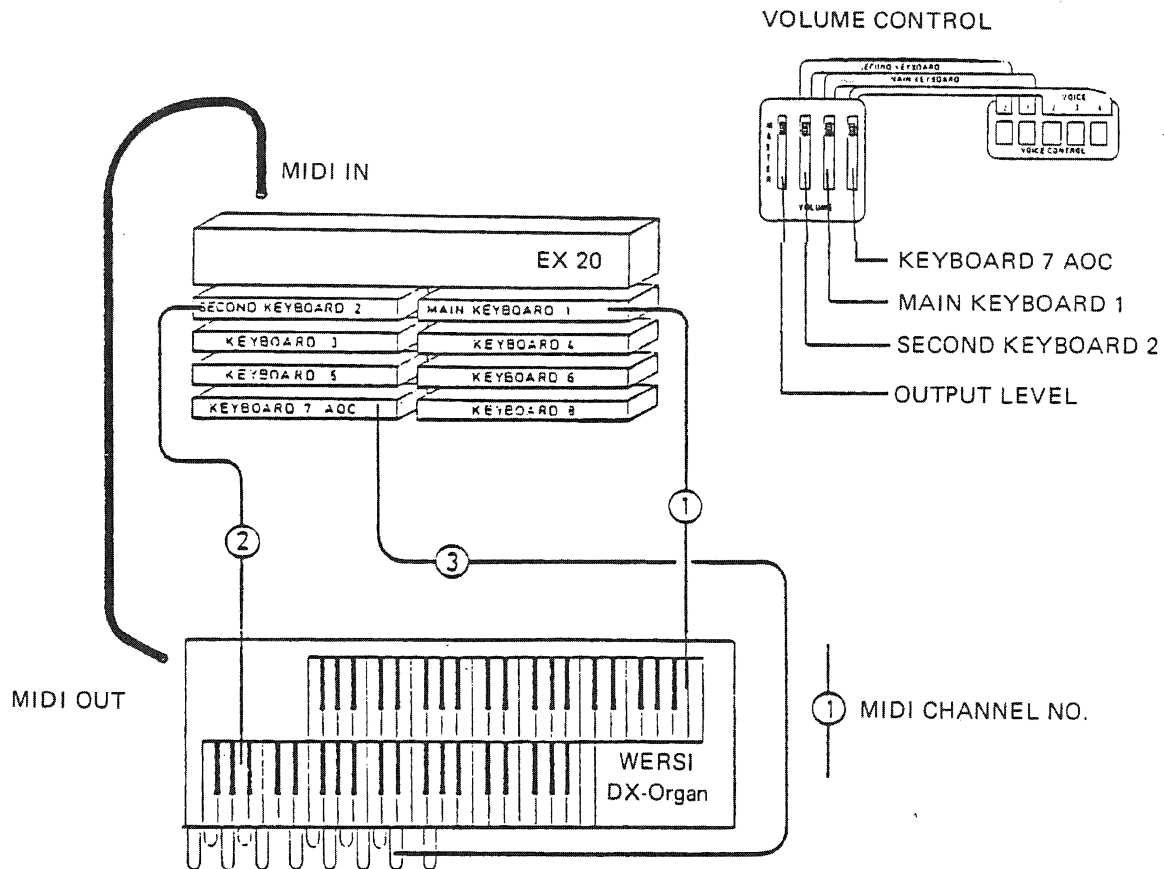

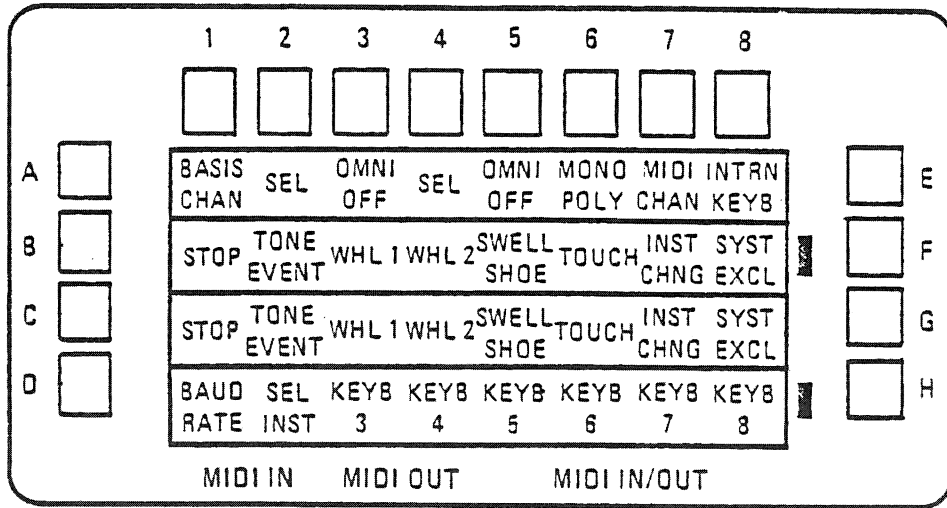

The EX 20 automatically selects the MIDI Level of the Function Control Matrix after being turned on.

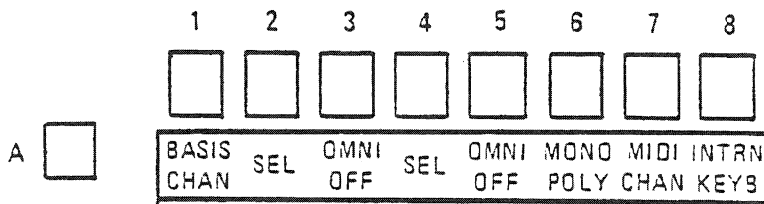

You can now assign all 8 internal keyboards individually to separate MIDI receiving channels:

- 1

— Depress switch 1 (LED on).

BASIS CHAN

In the function field of the Display you will see that the Basis Channel is selected.
- 7

— The Basis Channel can now be set by repeatedly depressing switch "7".

MIDI CHAN
- 8

— By repeatedly depress switch "8" you can now assign an internal keyboard to the Basis Channel.

INTRN KEYB

Example:



Basis Channel is Channel 1. On this channel the MAIN KEYBOARD 1 (Right Hand Selector) receives voice and mode data.

**NOTE:** Remember:

- MIDI Mode information can only be evaluated on the Basis Channel.
- MONO Mode information is not accepted on the Basis Channel.
- "MIDI IN" is always in the POLY Mode.
- Wheel 1 & 2, Volume Pedal, and Dynamic information can only be received on the Basis Channel. (See also Matrix Control line "B" "MIDI IN" in the MK 1 User's Guide.

2



SEL

- Depress switch 2 (LED on).

With selector switches "7" and "8" you can now assign all internal keyboards – except the Basis Channel – to a MIDI receiving channel.

- Select the MIDI channel you desire by repeatedly depressing switch "7" – watch the Display in the function area to set the correct channel number.
- After you have selected the desired MIDI channel, use switch "8" to assign each one to an internal keyboard.
- With switch "7" select the next MIDI channel, etc., etc.
- Turn off MIDI channels not in use by assigning blanks to them –  
Example: 12 ↘

Channel assignments will remain in the EX 20 memory even after turning the EX 20 off and then back on again.

MAIN KEYBOARD 1 and SECOND KEYBOARD 2 are programmed in the "VOICE CONTROL" section of the control panel. Please refer to the MK 1 User's Guide in the section titled "DMS Instruments", and in the chapters involving the "Sound Voice System and Multi-Sound-Creating" areas.

The registration involving the Internal Keyboards 3 thru 8 is discussed in the MK 1 User's Guide under the MIDI level section, Line "D".

### 3. SELECTING MIDI-MODE

As you know, in the MIDI-Mode, the EX 20 always operates in the POLY-MODE. The OMNI-MODE, however can be turned On and Off with switch "3".



– Depress Switch "3" LED on = OMNI OFF/POLY MODE:

All 8 keyboards are activated and receive data on the MIDI channel assigned to them.

OMNI OFF / POLY MODE  
(SWITCH A,3 LED ON)

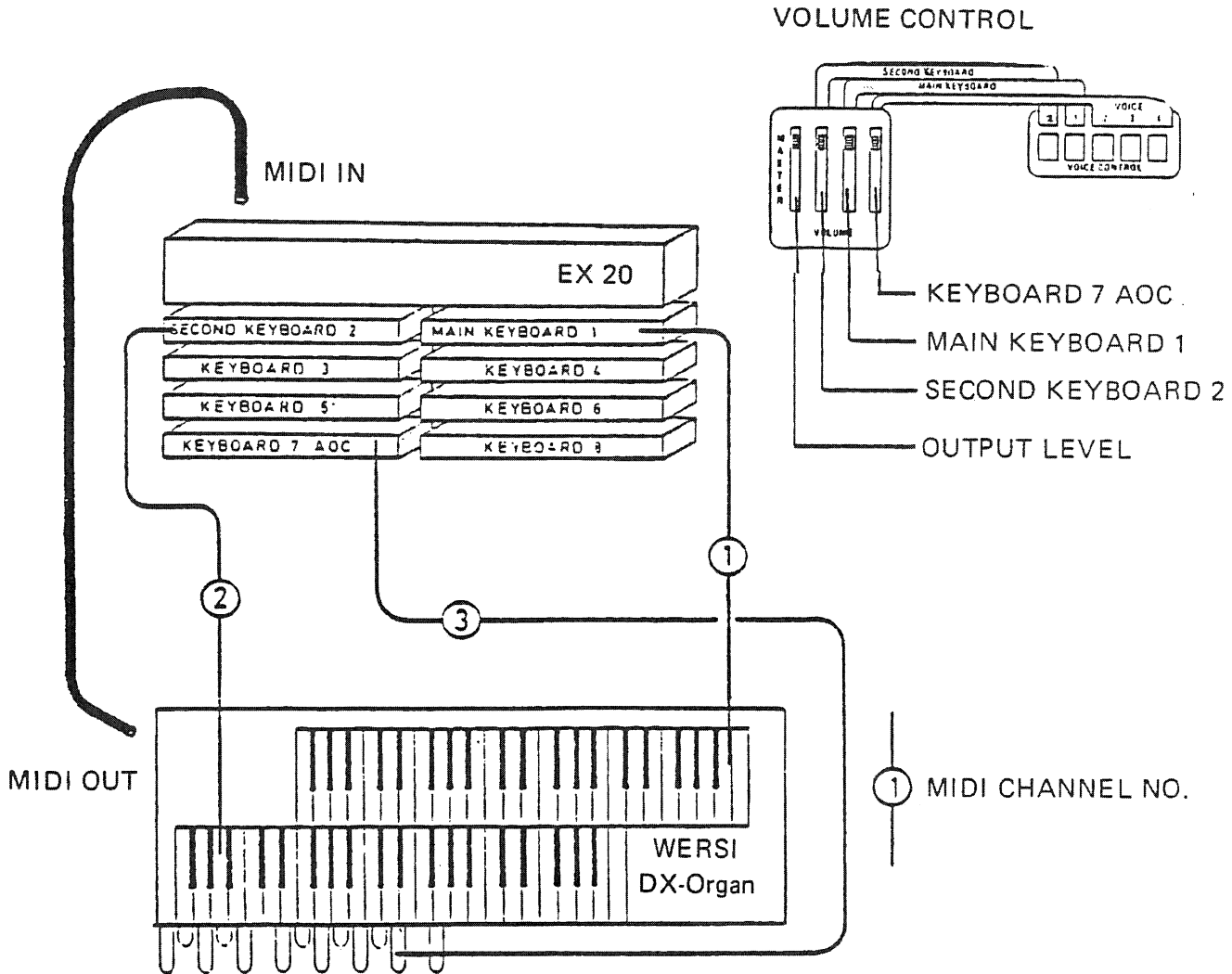

- Depress "3" (LED off) = OMNI ON/POLY MODE:

Only the Basis keyboard is activated and receives data from all MIDI channels.

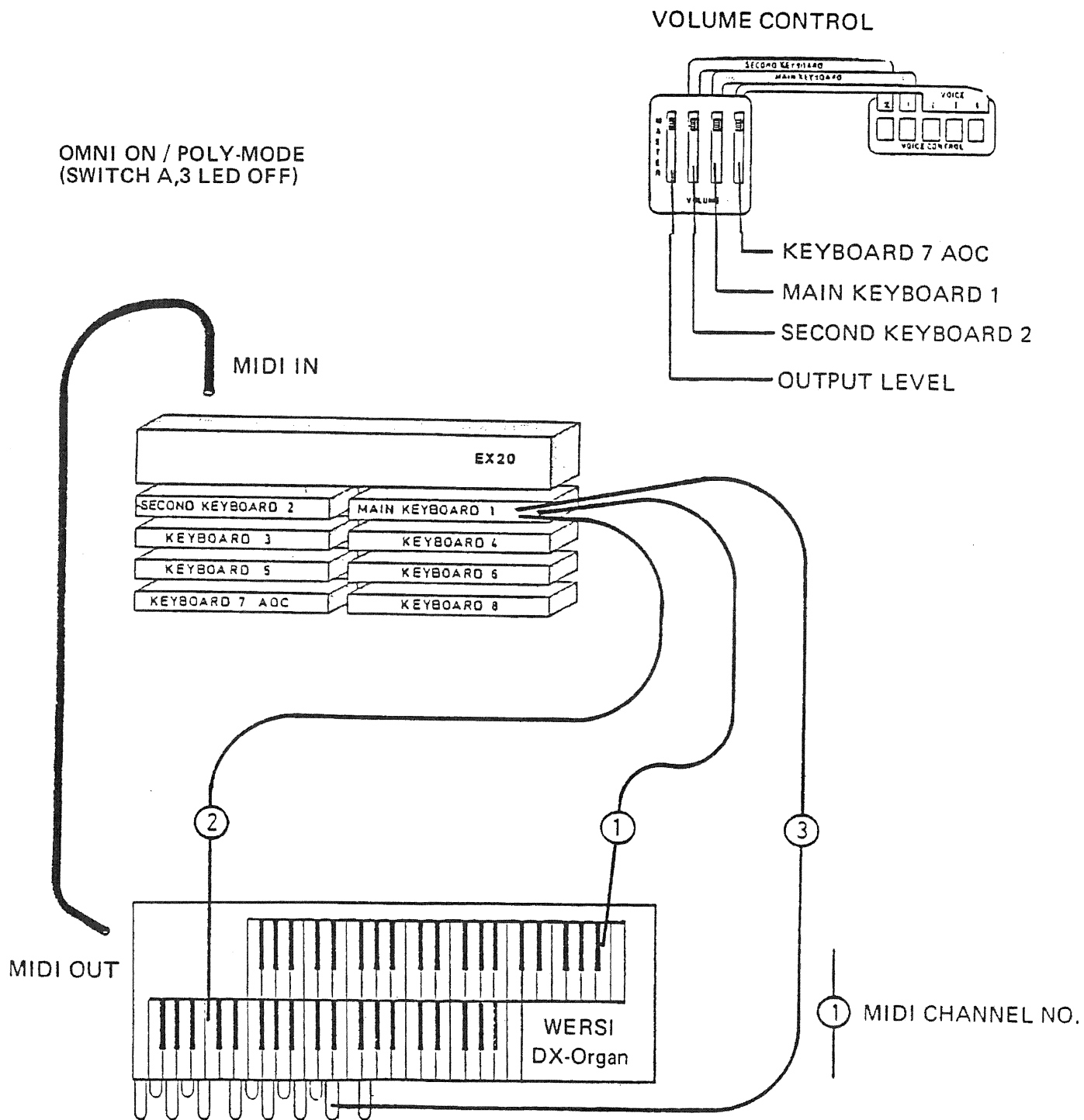

#### 4. SETTING THE RANGE OF VOICE INFORMATION

In line "B" of the MIDI User's Matrix you will find a listing of voice messages the EX 20 is capable of receiving. Through activating or turning off individual functions it is possible to set the range of voice information.

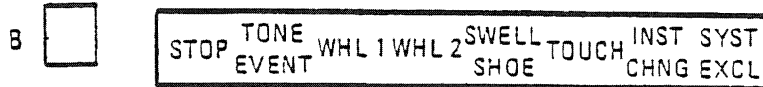

The function of these 8 switches is described in detail in the MK 1 User's Guide under MIDI Level "B" on Page 66.

#### Important NOTES:

- a) When Switch "1" is activated (LED on), the Ex 20 will not receive MIDI data. Therefore, in MIDI operation make sure that this function is turned OFF (LED off).
- b) MIDI Data for Wheel 1 and 2 are received on the Basis Channel. This data is interpreted through the EX 20's internal programming. (See PLAY LEVEL, "G" in MK 1 User's Guide on Page 36 "WHEELS".)
- c) MIDI Data for "Touch" is also received on the Basis Channel and is interpreted through the EX 20's internal Touch Programming. (See PLAY LEVEL, "F" in the MK 1 User's Guide on Page 34 "EFFECTS".);

\*This function is operable only if the transmitting keyboard is a Touch Sensitive keyboard.

#### 5. REGISTRATION OF THE INTERNAL KEYBOARDS

On the EX 20 up to 8 internal keyboards can be assigned voices individually. (OMNI OFF/POLY MODE)

MAIN KEYBOARD 1 and SECOND KEYBOARD 2 are registered in Bank Right and Bank 2.

The total instrumentation for a keyboard (Voice 1-4) is described as a BANK.

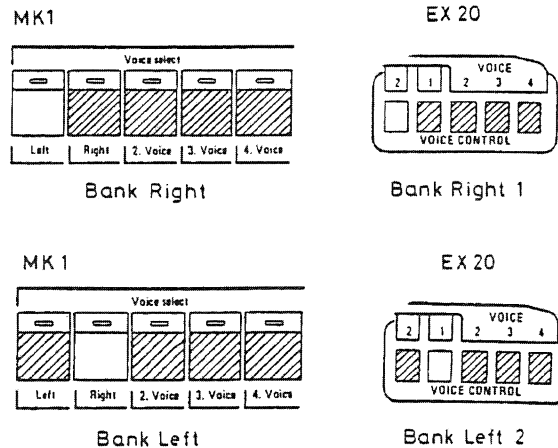

**COPY FROM CURRENT SELECTOR**

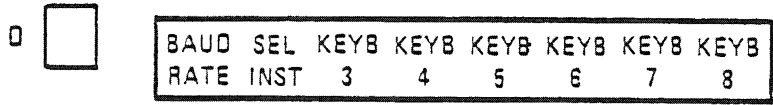

To register an internal keyboard, an instrument from the Main Keyboard Selector (Voice Control switch 1 LED on), or Second Keyboard Selector (Voice Control switch 2 LED on) is copied into the internal keyboard. An external (MIDI Out) keyboard can then access and play the sound on this internal keyboard if both are transmitting or receiving on the same MIDI Channel.

**Example:** Copy "Piano" into the internal keyboard "AOC 7".

\*We are using the example of Internal Keyboard "AOC 7" because it has its own volume control.

- Load DMS instrument "Piano" into the Right Bank (= MAIN KEYBOARD). In the "Voice Control" section of the operating panel only the switches "1" and "Piano" should be on. (LEDs on)
- Depress switches "H", "F", and "D" (LEDs on) to access MIDI Level row "D". (IMPORTANT: The LED in switch "2" – Select/Instr. – must be off.)
- Depress "Keyboard 7" switch and the LED will light briefly.

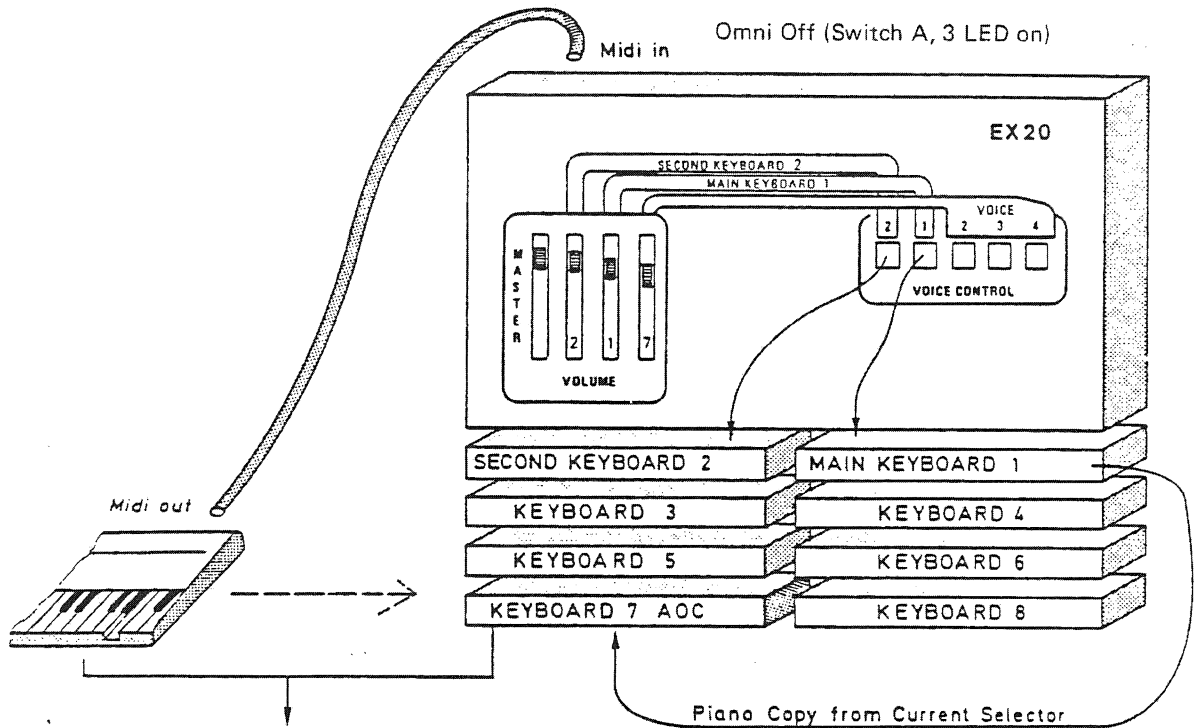

Set same MIDI Channel for transmitter and receiver.



The DMS Instrument "Piano" is now copied into "AOC 7" and can be accessed through MIDI. Make sure that the MIDI transmitter and receiver are using the same MIDI channel.

Three keyboards can now have their volume levels controlled individually.

- MAIN KEYBOARD 1 (= Manual Right)
- SECOND KEYBOARD 2 (= Manual Left)
- KEYBOARD AOC 7 (Internal Manual AOC 7)

The internal Keyboard "AOC 7" is now registered with DMS Instrument "Piano" and can now be accessed through MIDI.

The other internal keyboards can also be registered for MIDI using the same format as just described.

#### D. MIDI-DIRECT MODE

In MIDI, not only can you access all of the internal keyboards, but you can also simulate the Key Dynamics of the MK 1 keyboard. Through this you can use functions which can be activated from the MK 1 keyboard, but not from MIDI. These functions include, for example, "Doubling", "Solo" and "AOC".

The MIDI-Direct Mode is the standard setting for the EX 20 and should remain active for normal use. Here is an exception to this rule: MIDI-Direct Mode should be turned OFF if MAIN KEYBOARD 1 and SECOND KEYBOARD 2 are receiving Data through or over more than one MIDI channel. In this case (when they are receiving on more than one MIDI channel) the internal notes can no longer be distinguished from external MIDI notes and the two notes are interpreted in the same way. The MIDI-Direct Mode is displayed on VI Special Controls level.

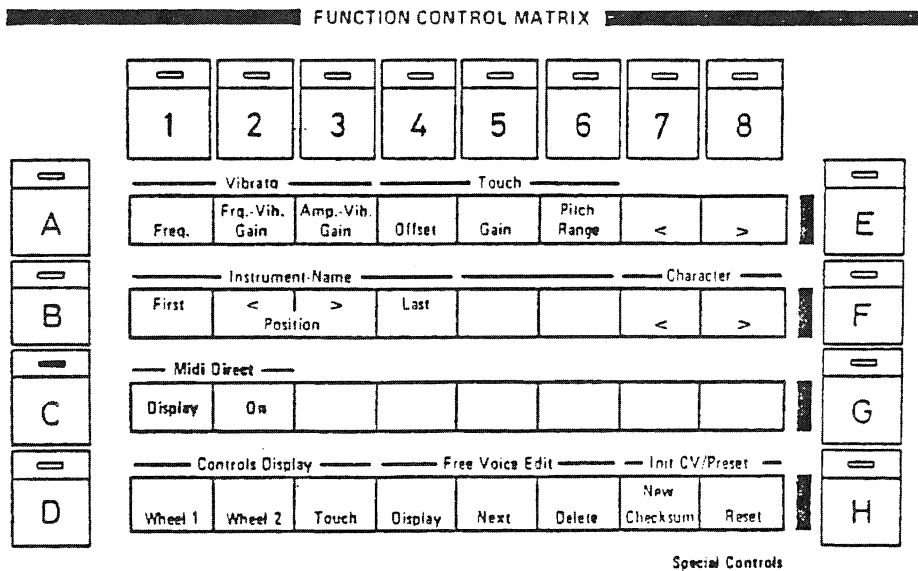

To see if the MIDI-Direct Mode is activated:

- Depress switches “H”, “G”, “F”, “E” and “C” (LEDs on).

To see if MIDI-Direct Mode is on or off:

- Depress switch “1” (Display).

If when you depress switch “1” (Display) the LED on switch “2” also lights and then the MIDI-Direct Mode is turned off. Through depressing switch “2” repeatedly you can turn the MIDI-Direct Mode on or off.

When the EX 20 is reset, or turned off and then on again, the MIDI-Direct Mode is automatically activated. The switches “Split On” and “Set Split” in the play level through which the keyboard of the MK 1 can be split are of no function on the EX 20.

MIDI keyboards connected to the EX 20 can be split only if they themselves have the keyboard split function. For an example: the WERSI MIDI Keyboard M 88.

## E. CHECKLIST FOR PROBLEMS

Problems in MIDI operation can have a variety of causes.

To make it easier for you to find causes, we have prepared a checklist of the most frequently made mistakes.

### CHECKLIST

**Problem:** Notes do not sound.

Possible Causes:

- MIDI cable not connected properly, EX 20: MIDI in/Sender-Keyboard: MIDI out.
- Have you forgotten the audio cable?
- Possibly you have turned on EX 20 Omni OFF/Poly Mode but the receiving and transmitting channels are not set to correspond correctly.
- The volume controls are set too low or are off.
- The volume pedal is set too soft or is off.
- MIDI is set in the STOP Mode (LED in “B” “1” is on).
- TONE EVENT in MIDI is not activated (LED in “B” “2” is off).
- “Drawbars” is selected and none are pulled out (at least one has to be pulled out to obtain sound).

- The MIDI Baud Rate is incorrect (the correct baud rate of 31, 25 k Baud should be shown in the Display). If the EX 20 is connected to the WERSI MK 1, then you can also select the double speed of MIDI transfer of 62.5 K baud. The transfer speed has to be the same on the transmitter and receiver.
- There are four DIL Switches on the AF 20 PC Board: the right or left pair has to be switched to "ON".
- On the EX 20 input: the cable is not plugged in or is not plugged in correctly.

**PROBLEM:** Notes sound through or they do not come through, MIDI in operates defectively.

Problem Causes:

- MIDI cable too long or of poor quality.
- If notes sound through, this can be corrected by depressing "STOP" (MIDI Level "B") two times.
- Changing registrations on the receiver while playing could result in a tone "ON" but no tone "OFF" information. Correct with "STOP".

**PROBLEM:** Keyboard is detuned or detunes while playing.

Problem Causes:

- Touch with Pitch or Vibrato programming in the (PLAY LEVEL).
- Footswitch has Hawaii or Transposer assigned (MODE CONTROL LEVEL).
- Pitch or Transposer are incorrectly set (PLAY LEVEL, SHIFT ALL).

**NOTE:** Besides the 6 levels of the Function Control Matrix, which control all of the playing functions of the EX 20, there is also a 7th Level which is exclusively for internal testing purposes and has no playing function. This 7th Level is accessed if the LEDs "H", "E" and "F" in the Matrix Switches are on. Make sure that on the 7th Level the LEDs of switches "A" to "D" and "1" to "8" are not on since otherwise pitch detuning will occur.

## F. CHANGING FUSES

### Fuse Holder:

The Fuse Holder, which is normally built as an integral part of the voltage plug (sometimes separate), should be unscrewed with a small screwdriver and then pulled out like a small drawer. When the small plastic hook in the center of the fuse holder is pulled out, you can then pull out the small board which is the actual fuse carrier.

Replace the safety cover and return the fuse holder to its original position in the EX 20.

**CAUTION:** If 110 V is required, make sure you return the fuse holder to its correct position. To do this, align the 110 side of the Fuse Holder with the marker on the bottom of the Fuse Holder Mounting in the EX 20. (Align with small notch in the bottom of the Fuse Holder Mounting.)

### For 220 V use:

Replace the top fuse with a 0.4 Amp fuse.

### For 110 V use:

Replace the bottom fuse with a 0.8 Amp Fuse.

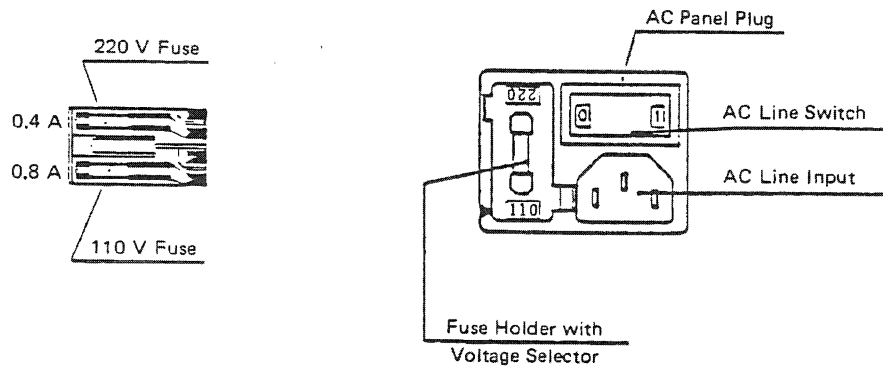

## APPENDIX

### G. PREPARATIONS FOR MIDI DATA TRANSFER

You must prepare WERSI instruments for MIDI functions before you can transmit or receive data.

The following commands must be entered on all WERSI DMS Instruments. Other brands of instruments refer to individual user's guides.

#### 1. ALPHA DX 300 AND CONDOR KEYBOARD DX 100

Instrument "on" out of reset position.

Transmit

– "COMPUTE", "S", "I", "COMPUTE", "PROGRAM"

The instrument is ready to send MIDI information. All manuals plus registration information will be sent. "PROGRAM" sends registration information.

Receive

– "COMPUTE", "W-E-R-I", "COMPUTE"

– in addition –

– "COMPUTE", "W-R-I", "COMPUTE", "PROGRAM"

The instrument will receive MIDI information in original volume, manuals and pedals, and registration information.

#### 2. ALPHA DX 350 / DX 400/500 BETA / GAMMA / DELTA;

Instrument "on" – out of reset position.

ACTIVATE TRANSMIT and RECEIVE MODE:

- "COMPUTE" "E-S" "COMPUTE" = volume 1-1
- "COMPUTE" "W-E-S" "COMPUTE" = MIDI out + Reg. information.
- "COMPUTE" "W-R-S" "COMPUTE" = MIDI in + Reg. information.
- "INTERFACE" "R-S-I" "COMPUTE" = MIDI in + out active.

### 3. CHANNEL ASSIGNMENTS within WERSI DX 350 and DX 400/500 INSTRUMENTS

Channel 1	Upper Manual	with vcf information
Channel 2	Lower Manual	
Channel 3	Pedal	
Channel 4	UM-Orchestra	
Channel 5	WERSI chord	
Channel 6	Autoaccompaniment	solo
Channel 7	Autoaccompaniment	chord
Channel 8	Autoaccompaniment	bass
Channel 9-15	not used	
Channel 16	Rhythm	

The Rhythm units CX 3, CX 3S and CX 4 will not send MIDI information.

Rhythms can be transferred through the Lower Manual on channel 16.

The velocity sensitive keyboards will also transfer information when entering Rhythms.

Not available on DX 300 models or on units 400/500 with 3.35 software.

TONE	MIDI	CX-4 (DX 400/500)	CX-3 (DX 350)
C	36	Bassdrum 3	
C#	37	Rimshot	
D	38	Disco Snare	
D#	39	Clap	
E	40	Snare	
F	41	Tom low	
F#	42	Hihat closed	
G	43	Tom low	
G#	44	Hihat closed	
A	45	Tom high	
A#	46	Hihat open	
H	47	Tom high	
C	48	Bongo low	Bassdrum 3
C#	49	Cymbal 1	Hihat open
D	50	Bongo high	Disco Snare
D#	51	Cymbal short	Clap
E	52	Crash Cymbal	Snare
F	53	Brush	Tom low
F#	54	Wood Block	Hihat closed
G	55	Tambourine	Tom low
G#	56	Cowbell	Hihat closed
A	57	Maracas	Tom high
A#	58	Cowbell 2	Hihat open
H	59	Whistle	Tom high
C	60	Wood Block	Bongo low
C#	61	Bassdrum	Cymbal 1
D	62	Disco Bassdrum	Bongo high
D#	63	"Hey"	
E	64	"Aha"	
F	65		
F#	66		Wood
G	67		Tambourine
G#	68		Cowbell
A	69		
A#	70		
H	71		Whistle
C	72		Wood Block
C#	73		Bassdrum
D	74		Disco Bassdrum

DX 350 / 400 / 500 "COMPUTE", "I", "COMPUTE"

Printed in U. S. A.

We reserve the right to change our products and specifications without notice.

Reproduction of this manual, entirely or in part, is permitted only with our consent.

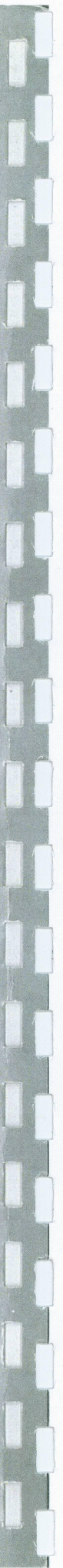
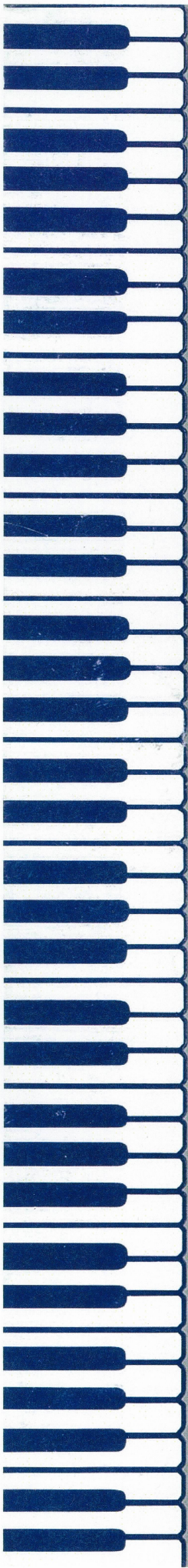

## **LANCASTER, PA**

WERSI ELECTRONICS, INC.  
1720 Hempstead Rd., Box 5318  
Lancaster, PA 17601

Call: 1-800-233-3865  
In PA: (717) 299-4327  
Technical Service: (717) 295-9471

## **LOS ANGELES, CA**

WERSI ORGAN & PIANO  
14104 E. Firestone Boulevard  
Santa Fe Springs, CA 90670

Call: 1-800-221-9590  
Outside CA: (213) 802-2891  
Technical Service: (213) 921-8970