

CPS 1 / CPS 2

CINEMA PRECISION SERIES

SPECIFICATIONS

Technical Specifications: CPS1, CPS2

Amplifier at rated conditions, both channels driven with 8 ohms loads, unless otherwise specified.

	CPS1			CPS2		
	8 Ω	4 Ω	2 Ω	8 Ω	4 Ω	2 Ω
Load Impedance	8 Ω	4 Ω	2 Ω	8 Ω	4 Ω	2 Ω
Maximum Midband Output Power THD=1%, 1kHz	280W	450W	650W	380W	600W	850W
Rated Output Power THD < 0, 2%, 20Hz ... 20kHz	230W	350W	450W	300W	500W	650W
Maximum Bridged Output Power THD=1%, 1kHz	900W	1300W	————	1200W	1700W	————
Maximum RMS Voltage Swing THD=1%, 1kHz	56V			64V		
Voltage Gain at 1 kHz	34dB			35dB		
Slew Rate	25V/μs			30V/μs		
Power Consumption at 1/8 maximum output power @ 4 Ω	690W			870W		
Input Sensitivity at rated output power @ 4 Ω, 1 kHz	0dBu (775mV)					
THD at rated output power, MBW=80kHz, 1 kHz	< 0.05 %					
IMD-SMPTE 60 Hz, 7 kHz	< 0.08 %					
DIM30 3.15kHz, 15 kHz	< 0.03 %					
Crosstalk ref. 1kHz, at rated output power	<-80 dB					
Frequency Response -1dB, ref. 1 kHz	13Hz ... 45kHz					
Power Bandwith THD=1%, ref. 1kHz, half power @ 4 Ω	10Hz ... 50kHz					
Input Impedance 20Hz ... 20 kHz, balanced	20kΩ					
Damping Factor at 100Hz / 1kHz	>300 / >200					
Signal to Noise Ratio A-weighted	103dB					
Power Requirements	120V, 50Hz ... 60Hz					
Protection	Audio limiters, High temperature, DC, HF, Back-EMF, Peak current limiters, Inrush current limiters, Turn-on delay					
Cooling	Front-to-Rear, 3-stage-fans					
Safety Class	I					
Dimensions (W x H x D), mm	483 x 132.5 x 385.5					
Weight	15kg			16kg		

MEASUREMENT SPECIFICATIONS: CPS1 & CPS2 complete appliance

printed board assembly names and their corresponding EDP-numbers:

Printed board assembly EDP-number			
120V		230V	
CPS1	CPS2	CPS1	CPS2
84183	84184	84181	84182

Printed board assembly	Index
Main PCB	1
Supply PCB	4
Input PCB	2
LED PCB	3

measuring condition; if not otherwise specified:

- tolerance of measured values: $\Delta X = \pm 1.5 \text{ dB}$
- measuring frequency: $f = 1 \text{ kHz}$
- stated levels refer to: $U = 775 \text{ mV (0 dBu)}$
- level controls set to their clockwise limits
- pin assignment of the XLR-type connectors:
 - PIN 1: ground / shielding
 - PIN 2: + INPUT
 - PIN 3: - INPUT
- source resistance for the induction via the XLR-type connector: $R(Q) = 50 \Omega$
- the AMPLIFIER PCB printed board assembly is provided with **service connectors**

CNS1		CNS2		CNRC	
PIN	assignment	PIN	assignment	PIN	assignment
1	-Vcc	1	LIM A Switch	1	LIM Out A
2	BIAS +A	2	-15V	2	LIM Out B
3	BIAS -A	3	LIM B Switch	3	Standby via RC
4	FAN Voltage	4	+15V	4	Standby LED
5	+Vcc	5	AGND	5	-Vss
6	BIAS +B	6	Speaker Out A	6	+Vss
7	BIAS -B	7	Relais/Protect	7	n.c.
8	Temp Heatsink	8	Speaker Out B	8	n.c.

1. Operating voltage:

$U(B) = 120V, 230V, 240V \ 50Hz \dots 60Hz$

2. Deviation limit of the operation voltage:

-30% +10%

3. Power consumption (both channels driven) $f = 1kHz$

	CPS1	CPS2
Idling power consumption	30-60W	40-80W
Nominal power consumption (RL=4Ω)	1400W	1900W
Standard power consumption (RL=4Ω)	430W	600W
Maximum power consumption (RL=4Ω)	1650W	2100W
Power consumption at 1/8 of the maximum output power	690W	870W

4. Settings / adjustments

4.1. IDLING CURRENT ADJUSTMENT

Connect the DC-volt meter at the BIAS measuring points (see service connector) and adjust the idling current via the trim potentiometer VR101/VR301 (on the main PCB printed board assembly). Adjust both channels of the power amplifier A&B to a value of $U(\text{DC}) = 7.5 \text{ mV}$. Adjusting the idling current has to be performed at normal room temperature. In case the power amplifier was previously in operation, it needs several hours for cooling off.

4.2. VCA - OFFSET

Rhythmically open and short-circuit the CNS2.1 and CNS2.2 on the main PCB printed board assembly for channel A; respectively CNS2.3 and CNS2.2 for channel B. Use VR100 respectively VR300 for adjusting the power amplifier outputs to their minimum offset (with oscilloscope to minimal peak value or to the audible minimal volume of the interfering pulse).

5. Testing of functions

5.1. OUTPUT - offset voltage

DC-voltage measuring at the SPEAKER A/B outputs with $U(\text{DC}) \leq \pm 10 \text{ mV}$.

5.2. LIMITER

5.2.1. attenuation test

Channels separately driven with a 1 kHz signal up to $U(\text{A}) = 42.4 \text{ volts}$, respectively $U(\text{A}) = 49 \text{ volts}$ (without load). Increase the input voltage by 10 dB. The LIMITER LED lights and the output voltage increases by about 2 dB to approx. 58 volts – respectively 64 volts; with slight clipping. The distortion rate of the limited signal is at THD = 1.0 ... 1.5 %. Increasing the input signal up to a value of +20 dBu should not result in remarkably higher clipping.

5.2.2. attack and release times

separately test both power amplifier channels: testing without load resistors

- 1.) Drive the power amplifier input with a burst signal ($f = 1 \text{ kHz}$, 10 cycles, rate: $\approx 0.5 \text{ sec.}$)
- 2.) and $U(\text{E}) = +10 \text{ dBu}$.
- 2.) Monitor the output signal via oscilloscope. After 4 - 5 signal periods, the limiter controlled the major distortion down to a minor residual distortion (THD = 1.0 ... 1.5 %).
attack time: 4 - 5 mS release time: 40 - 50 mS

5.3 POWER-ON DELAY

Signal present at the power amplifier input. Use the power-on switch to switch the power amplifier's power on. Approximately 2 seconds after switching the power on, the signal is present at the amplifier's output.

5.4 FAN CONTROL

Upon powering-on the power amplifier, the fans will run for about 2 seconds and then stop; presuming that the amplifier's temperature is not too high. In idling condition (power-on, no signal present) the fans are switched between the SLOW and OFF (0 V) mode, depending on the heat sink's temperature. When CNS1.8 is connected via a 5k1 ohms resistor to +15 V, the fans will run in SLOW mode. Fan-voltage of 16.8 V DC measured between Pins CNS2.4 and CNS1.4. Disconnecting the plug CN5 results in the fans running at FAST speed. Fan-voltage of 28 V DC measured between Pins CNS2.4 and CNS1.4

5.5. SOAR-PROTECTION CIRCUIT TEST

Channels separately driven on 4 Ω up to 49 volts; respectively 42.2 volts. Parallel connect a 1 Ω resistor. The protection circuit reacts and tries continuously to re-start! The protect-LED lights. Repeat the test with a 2 Ω resistor; the power amplifier should not switch off.

5.6. SHORT-CIRCUIT CURRENT-LIMITING TEST

separately test both power amplifier channels without load:

- drive the channel with a burst signal ($f = 1 \text{ kHz}$, 1 - 3 cycles, rate $\approx 1 \text{ sec.}$) with $U(\text{E}) = 1 \text{ Vrms}$

- connect a load resistor of 1 Ω the short-circuit current-limiter limits the output voltage at the load resistor symmetrically (monitor via oscilloscope) to a peak voltage value of 35 V, respectively 27 V (approx. 35 A respectively 27 A maximum peak output current).

5.7. DC-VOLTAGE PROTECTION CIRCUIT TEST

separately test both power amplifier channels:

- drive the power amplifier with a test signal ($f = 7$ Hz) and without load
- at an input voltage of approx. 3 V_{peak} the protection circuit reacts and tries continuously to re-start!
The protect-LED blinks with the same frequency.
- Repeat the test with $f = 14$ Hz; the power amplifier should not switch off.

5.8. HF-PROTECTION CIRCUIT TEST

Caution: it is mandatory to drive the power amplifier without load resistors connected.

Drive the power amplifier with a +20 dBu sine burst signal (40 mS ON, 960 mS OFF) $f = 100$ kHz applied to each channel at a time. The protection circuit should react. The power amplifier tries to re-start continuously. The PROTECT LED blinks with the same frequency.

Repeat the test with $f = 50$ kHz; the power amplifier should not switch off.

5.9. LED INDICATOR TEST

Apply a 1 kHz sine signal and increase its level. At approximately -30 dBu the SIGNAL LEDs will light and at about +1dBu the LIMIT LEDs light.

6. Level CHANNEL A B

6.1. voltage amplification

Unit	Input	U(E)	Measure point	U(A)	Load resistor	Test frequency
CPS1	CH. A/B	1Vrms	SPEAKER A/B	42V	∞	1kHz
CPS1	CH. A	1Vrms	BRIDGED OUT	84V	∞	1kHz
CPS2	CH. A/B	1Vrms	SPEAKER A/B	49V	∞	1kHz
CPS2	CH. A	1Vrms	BRIDGED OUT	98V	∞	1kHz

6.2. MAXIMUM INPUT LEVEL: $U(E) = +20$ dBu

7. GROUND LIFT switch

The circuit ground (at the input or the output connector) is measured versus the common ground of the enclosure (contact at the ground terminal, located on the rear panel - or common ground of the mains cord).

position of the switch: GROUNDED : $R = 0 \Omega$
UNGROUND : $R = 5 \Omega$

8. Amplitudes - non-linearities

- testing with load resistor 8 Ω , dual mode
- MDW = 80 kHz

Measuring	at nominal output		remarks
	CPS1	CPS2	
THD+N ($f = 1$ kHz)	<0.05%	<0.05%	
IMD-SMPTE	<0.08%	<0.08%	60Hz, 7kHz
DIM 30	<0.03%	<0.03%	3.15kHz, 15kHz

9. Frequency response

the frequency response is linear. (please take the cut-off frequencies into consideration)

	low cut-off frequency	high cut-off frequency
-3dB	$f_u < 10$ Hz	$f_o = 110$ kHz
-1dB	$f_u < 10$ Hz	$f_o = 57$ kHz

10. Factory default

BRIDGED MODE switch set to *NORMAL*

INPUT ROUTING switch set to *DUAL/STEREO*

LEVEL controls set at their clockwise margin.

11. Noise interference

- U(F) = external voltage un-weighted with B = 22 Hz ... 22 kHz, effective value (IEC 268-1)
- U(G) = noise voltage, frequency-weighting filter according to CCIR-468-3, quasi peak weighted (IEC 268-1)
- U(A) = interference voltage A-weighted, dB(A), effective value (IEC 268-1)
- Signal-to-noise ratio referring to maximum output voltage at 4 Ω and A-weighted interference voltage

Power Amp	output	U(F) dBu	U(G) dBu	U(A) dBu	GAIN dB	IN(A) dBu	S/N-R. dB	remarks
LEVEL controls set to their clockwise margin								
CPS1	SPEAKER OUT A&B	-67	-56	-69	32.5	-102.5	105	INPUT A&B R(Q) = 50Ω
CPS2	SPEAKER OUT A&B	-67	-56	-69	33.5	-102.5	105	INPUT A&B R(Q) = 50Ω
LEVEL controls set to their counterclockwise margin								
CPS1	SPEAKER OUT A&B	-68	-57	-70	/	/	/	INPUT A&B R(Q) = 50Ω
CPS2	SPEAKER OUT A&B	-68	-57	-70	/	/	/	INPUT A&B R(Q) = 50Ω

12. Dimensions and weight

Power amplifier	weight	Dimensions in mm
CPS1	15kg	483 x 132.5 x 385.5
CPS2	16kg	483 x 132.5 x 385.5

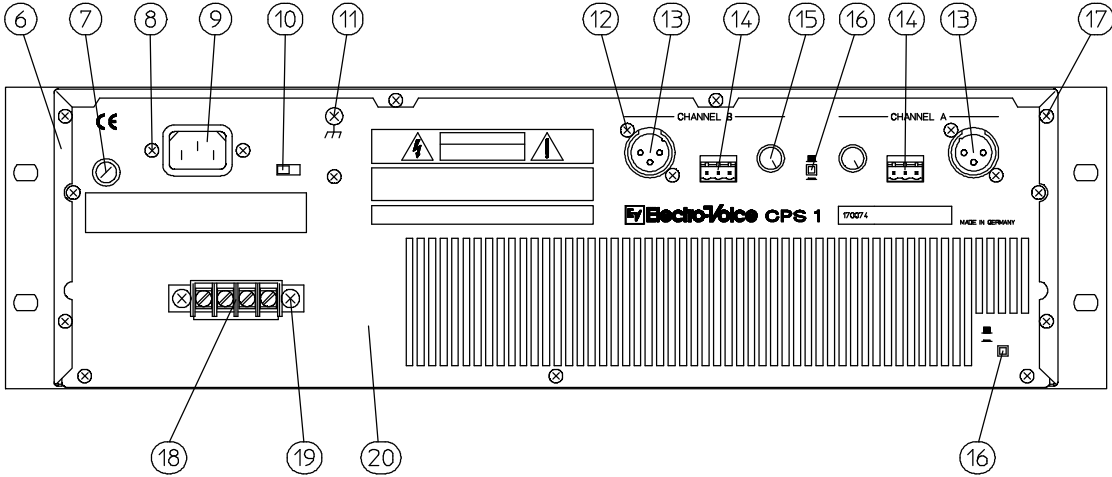
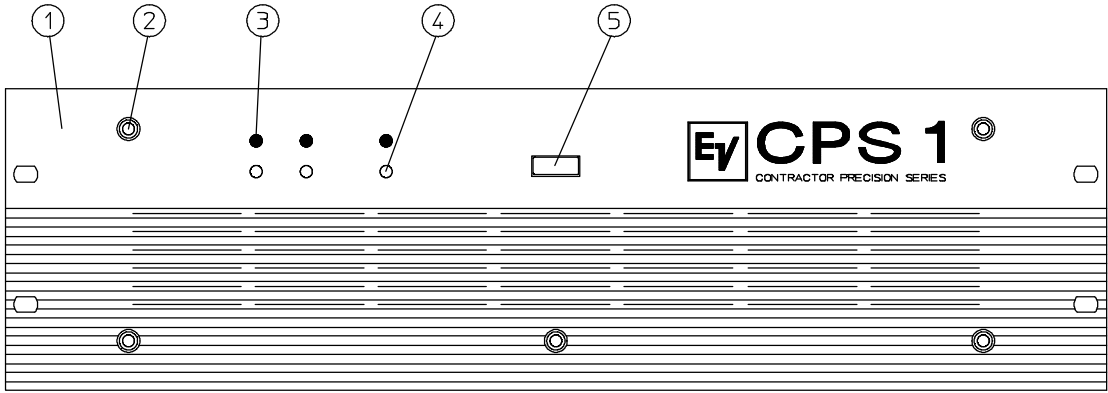

POS.	DESCRIPTION	PART.NO.
1	FRONT PANEL	355 670
2	SCREW M5x12	349 532
3	LED RED Ø5MM	354 546
4	LED GREEN Ø5MM	354 547
5	KNOB BLACK	341 382
	MAINS SWITCH	346 720
6	COVER	351 353
7	FUSE 8A SLOW BLOW	332 065
	FUSE-HOLDER	328 390
	FUSE-CARRIER	328 391
8	SCREW M3x8	335 203
	NUT M3	336 214
9	MAINS CONNECTOR	338 835
	POWER CABLE	354 617
10	SLIDE SWITCH	338 886
11	TAPPING SCREW 3.9x9.5	304 251
12	SCREW 30x8	344 229
13	XLR CONNECTOR (FEMALE)	351 815
14	3-PIN-EURO-STYLE	354 692
15	KNOB Ø11	355 449
	POTI 10K	343 250
16	PUSH SWITCH	344 037
17	SCREW M3x6	334 989
18	4-POLE-BARRIER-STRIP	354 959
19	SCREW M3x6	304 244
	NUT M4	347 808
20	REAR PANEL	355 780

Ohne unsere Genehmigung darf diese Zeichnung weder vervielfältigt, nach dritten Personen oder anderen Firmen zugänglich gemacht werden (siehe einschlägige Gesetze)

				1998		Tag		Name		SERVICE-INFORMATION	Maßstab 1:2
				Bearb.		05.11.		O. Kaiser			
				Gepr.							
				Stand		21300		O. Kaiser			
				a		22/00		16.3.		O.Kai	
				Ausgabe		Änderung		Tag		Name	
										3-	
										356 209	
										DYNACORD CPS 1 - 120V (170 074)	

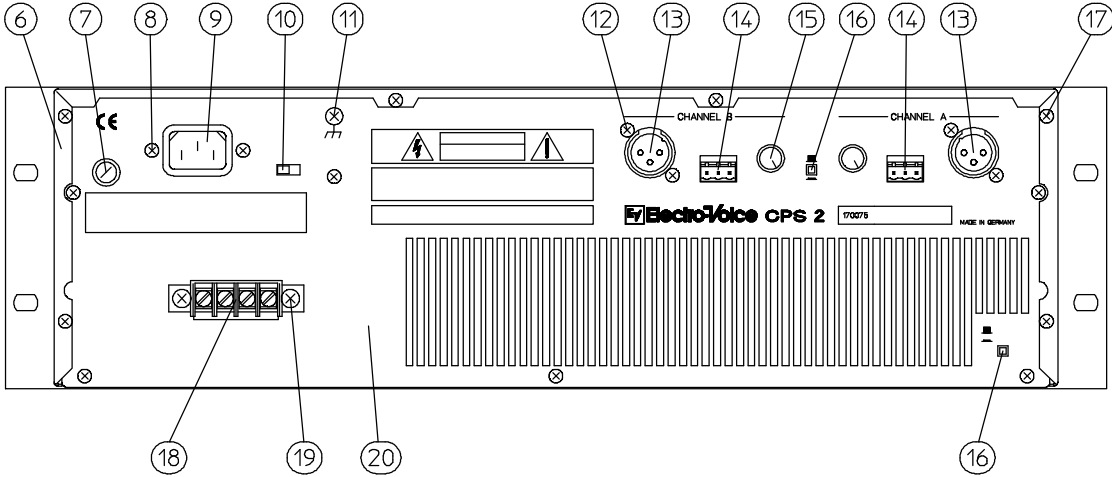
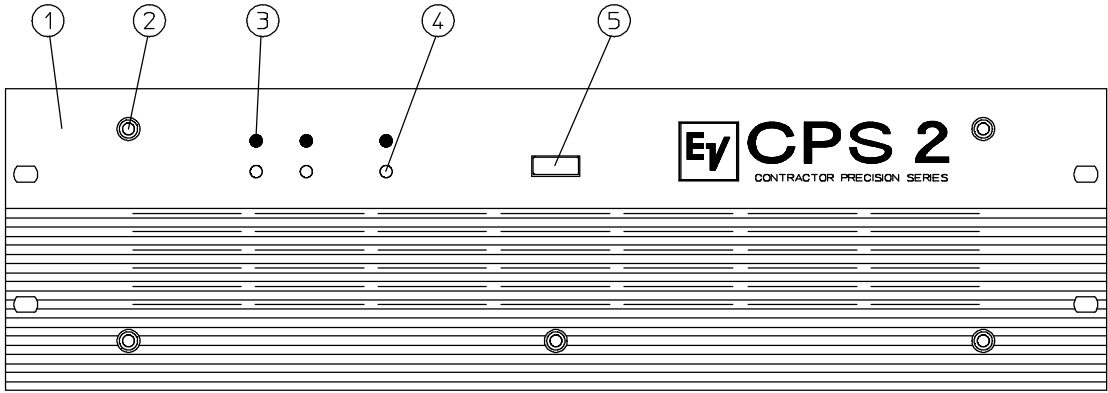

POS.	DESCRIPTION	PART.NO.
1	FRONT PANEL	355 672
2	SCREW M5x12	349 532
3	LED RED Ø5MM	354 546
4	LED GREEN Ø5MM	354 547
5	KNOB BLACK	341 382
	MAINS SWITCH	346 720
6	COVER	351 353
7	FUSE 10A SLOW BLOW	302 565
	FUSE-HOLDER	328 390
	FUSE-CARRIER	328 391
8	SCREW M3x8	335 203
	NUT M3	336 214
9	MAINS CONNECTOR	338 835
	POWER CABLE	354 617
10	SLIDE SWITCH	338 886
11	TAPPING SCREW 3.9x9.5	304 251
12	SCREW 30x8	344 229
13	XLR CONNECTOR (FEMALE)	351 815
14	3-PIN-EURO-STYLE	354 692
	KNOB Ø11	355 449
15	POTI 10K	343 250
16	PUSH SWITCH	344 037
17	SCREW M3x6	334 989
18	4-POLE-BARRIER-STRIP	354 959
19	SCREW M3x6	304 244
	NUT M4	347 808
20	REAR PANEL	355 781

Ohne unsere Genehmigung darf diese Zeichnung weder vervielfältigt, nach dritten Personen oder anderen Firmen zugänglich gemacht werden (siehe einschlägige Gesetze)

1998				Tag		Name		SERVICE-INFORMATION	Maßstab 1:2
Bearb.	05.11.			O. Kaiser					
Gepr.									
Stand	21300			O. Kaiser					
<p align="center">EV AUDIO DYNACORD</p>								356 280	3-
<p>a 22/00 16.3. O.Kai</p>								CPS 2 - 120V (170 075)	
Ausgabe	Änderung	Tag	Name						

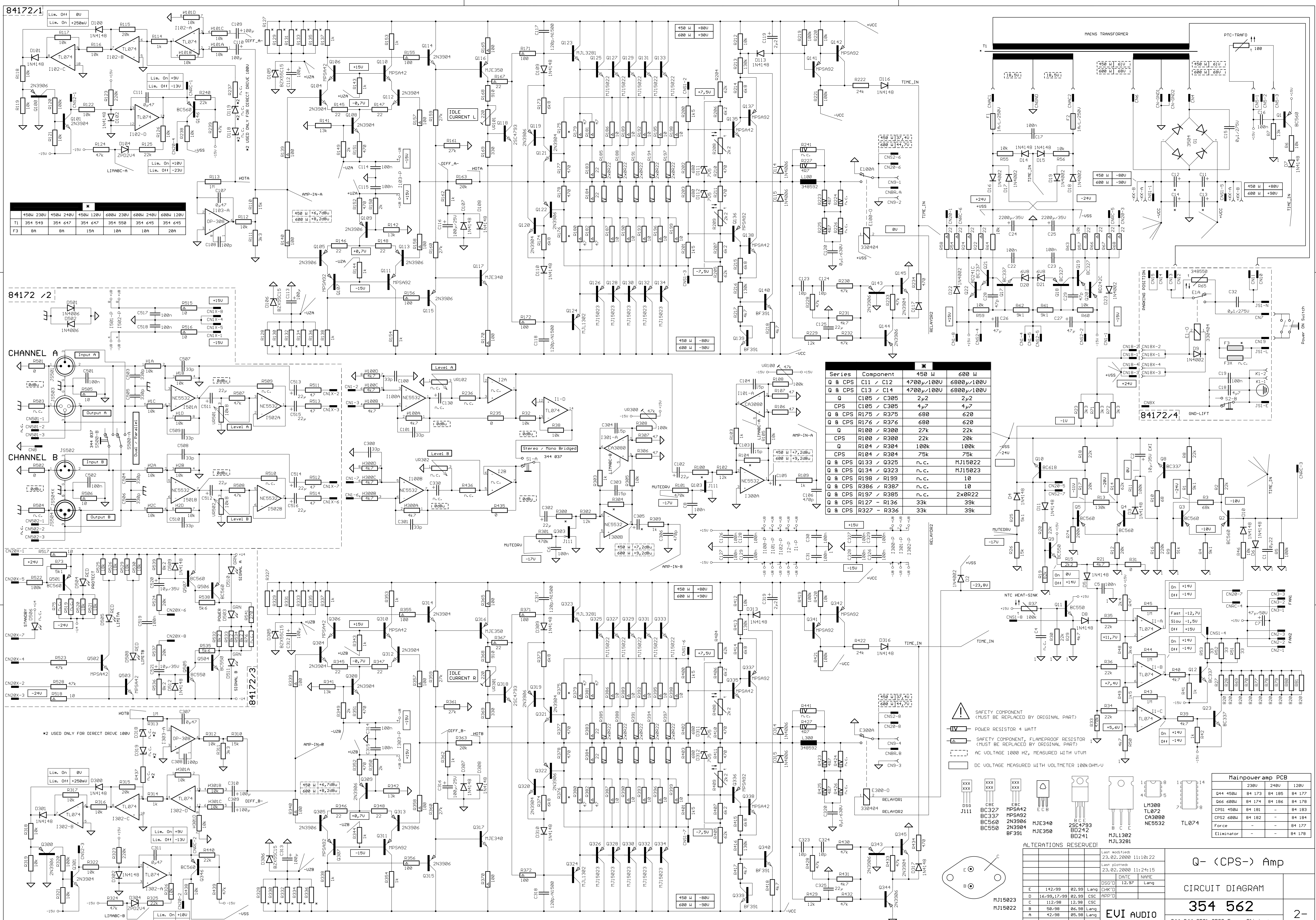

84172/1

84172/2

CHANNEL A

CHANNEL B

84172/3

84172/4

Series	Component	450 W	600 W
0 8	CPS C11 / C12	4700µ/100U	6800µ/100U
0 8	CPS C13 / C14	4700µ/100U	6800µ/100U
0 8	CPS C185 / C385	2µ2	2µ2
0 8	CPS C185 / C385	4µ2	4µ2
0 8	CPS R175 / R375	680	620
0 8	CPS R176 / R376	680	620
0 8	CPS R180 / R380	27k	22k
0 8	CPS R180 / R380	22k	20k
0 8	CPS R184 / R384	100k	100k
0 8	CPS R184 / R384	75k	75k
0 8	CPS Q133 / Q325	n.c.	MJ15022
0 8	CPS Q134 / Q323	n.c.	MJ15023
0 8	CPS R198 / R398	n.c.	10
0 8	CPS R386 / R387	n.c.	10
0 8	CPS R197 / R385	n.c.	2xØR22
0 8	CPS R127 - R136	33k	39k
0 8	CPS R327 - R336	33k	39k

- SAFETY COMPONENT (MUST BE REPLACED BY ORIGINAL PART)
- POWER RESISTOR 4 WATT
- SAFETY COMPONENT, FLAMEPROOF RESISTOR (MUST BE REPLACED BY ORIGINAL PART)
- AC VOLTAGE 1800 HZ, MEASURED WITH UTIM
- DC VOLTAGE MEASURED WITH VOLTMETER 100kΩ/10µA

- RELAYR1
- RELAYR2
- RELAYR3
- RELAYR4
- RELAYR5
- RELAYR6
- RELAYR7
- RELAYR8
- RELAYR9
- RELAYR10
- RELAYR11
- RELAYR12
- RELAYR13
- RELAYR14
- RELAYR15
- RELAYR16
- RELAYR17
- RELAYR18
- RELAYR19
- RELAYR20
- RELAYR21
- RELAYR22
- RELAYR23
- RELAYR24
- RELAYR25
- RELAYR26
- RELAYR27
- RELAYR28
- RELAYR29
- RELAYR30
- RELAYR31
- RELAYR32
- RELAYR33
- RELAYR34
- RELAYR35
- RELAYR36
- RELAYR37
- RELAYR38
- RELAYR39
- RELAYR40
- RELAYR41
- RELAYR42
- RELAYR43
- RELAYR44
- RELAYR45
- RELAYR46
- RELAYR47
- RELAYR48
- RELAYR49
- RELAYR50
- RELAYR51
- RELAYR52
- RELAYR53
- RELAYR54
- RELAYR55
- RELAYR56
- RELAYR57
- RELAYR58
- RELAYR59
- RELAYR60
- RELAYR61
- RELAYR62
- RELAYR63
- RELAYR64
- RELAYR65
- RELAYR66
- RELAYR67
- RELAYR68
- RELAYR69
- RELAYR70
- RELAYR71
- RELAYR72
- RELAYR73
- RELAYR74
- RELAYR75
- RELAYR76
- RELAYR77
- RELAYR78
- RELAYR79
- RELAYR80
- RELAYR81
- RELAYR82
- RELAYR83
- RELAYR84
- RELAYR85
- RELAYR86
- RELAYR87
- RELAYR88
- RELAYR89
- RELAYR90
- RELAYR91
- RELAYR92
- RELAYR93
- RELAYR94
- RELAYR95
- RELAYR96
- RELAYR97
- RELAYR98
- RELAYR99
- RELAYR100

- 25C4793
- 80242
- 80241
- MJ15022
- MJ15023
- MJ15024
- MJ15025
- MJ15026
- MJ15027
- MJ15028
- MJ15029
- MJ15030
- MJ15031
- MJ15032
- MJ15033
- MJ15034
- MJ15035
- MJ15036
- MJ15037
- MJ15038
- MJ15039
- MJ15040
- MJ15041
- MJ15042
- MJ15043
- MJ15044
- MJ15045
- MJ15046
- MJ15047
- MJ15048
- MJ15049
- MJ15050
- MJ15051
- MJ15052
- MJ15053
- MJ15054
- MJ15055
- MJ15056
- MJ15057
- MJ15058
- MJ15059
- MJ15060
- MJ15061
- MJ15062
- MJ15063
- MJ15064
- MJ15065
- MJ15066
- MJ15067
- MJ15068
- MJ15069
- MJ15070
- MJ15071
- MJ15072
- MJ15073
- MJ15074
- MJ15075
- MJ15076
- MJ15077
- MJ15078
- MJ15079
- MJ15080
- MJ15081
- MJ15082
- MJ15083
- MJ15084
- MJ15085
- MJ15086
- MJ15087
- MJ15088
- MJ15089
- MJ15090
- MJ15091
- MJ15092
- MJ15093
- MJ15094
- MJ15095
- MJ15096
- MJ15097
- MJ15098
- MJ15099
- MJ15100

Part	Value	Part	Value
444	450k	84	180
445	450k	85	180
446	450k	86	180
447	450k	87	180
448	450k	88	180
449	450k	89	180
450	450k	90	180
451	450k	91	180
452	450k	92	180
453	450k	93	180
454	450k	94	180
455	450k	95	180
456	450k	96	180
457	450k	97	180
458	450k	98	180
459	450k	99	180
460	450k	100	180

ALTERATIONS RESERVED!

Q- (CPS-) Amp

CIRCUIT DIAGRAM

354 562

EVI AUDIO

044-066/CPS1/CP52/Force/Eliminator

Ersatzteilliste - Bill of Materials

170074		CPS 1 US 120V POWER-AMP	
Pos. Nr.	Best. Nr.	Bezeichnung	Description
Ref. No.	Part No.		

Zubehör	Accessories & packing material
----------------	---

355745	OWNER'S MANUAL CPS 1/2	owner's manual CPS 1/2
354617	KABEL-NETZ UL/CSA 15A/125V	power cord US
337053	SCHUTZHÜLLE 650X800X0,08	poly bag
306482	KRT. 2 HE 556X507X178	carton
355741	STYROPOR-EINLAGE S900/Q44	filler, foam
355742	STYROPOR-PL. 500X370X20	filler, carton

Mechanische Teile	Cabinet material
--------------------------	-------------------------

G0010	343270	GLRI GBPC 3504	rectifier GBPC-P 3504
S0010	346720	SCHALTER-NETZ ESB-99888V	power switch
	354691	BUCHSENLEISTE 3POL	connector female 3-pole
	341382	KNOPF-TASTE 20X8 SW 3.3	push button black
	357958	DK 11 SW/WS/RT C 6FL	rotary knob
	337044	VERSCHL-KAPPE 2633 DP-437	plug, hole
	348415	LÜFTER TYP FBA08A24H DC	fan dc 24V
	349693	KABEL-KONFEKT 4POL 0.670M	ribbon cable assy 4-way
	346790	KABEL-KONFEKT 8POL 0.300M	ribbon cable assy 8way
	349612	KABEL-KONFEKT 8POL 0.400M	ribbon cable assy 8-way
	355670	FB.CPS 1 BED	front panel CPS1
	355743	CH.CPS 1/2	chassis CPS 1/2
	355780	RÜCKWAND BED. CPS 1 US	rear panel CPS1
	351353	DEC.3HE DEM-LAC/L16-2400LAC	top cover chassis
	354647	NT-RG.Q44/S900 120/240V	mains transformer 120/240V
	348805	WI-SO PTC K155 100GRAD	safety component PTC
	348341	FEDERLEISTE 3POL CE100-	connector female 3-pole

841838	PCB+AR#CPS 1	US	pcb assy 84183
---------------	---------------------	-----------	-----------------------

CNAC1	343516	FL.STECKER 4.8/0.5	connector 4.8mm faston
CNAC2	343516	FL.STECKER 4.8/0.5	connector 4.8mm faston
CNGND	343516	FL.STECKER 4.8/0.5	connector 4.8mm faston
CNGN1	330269	FL.STECKER 6.3/0.8	connector 6.3mm faston
CN001	344862	MESSERLST. 8POL	connector male 8-pin
CN002	348334	STIFTLEISTE 3POL MLSS	connector male 3-pin
CN003	348334	STIFTLEISTE 3POL MLSS	connector male 3-pin
CN005	348334	STIFTLEISTE 3POL MLSS	connector male 3-pin
CN007	330269	FL.STECKER 6.3/0.8	connector 6.3mm faston
CN01X	344862	MESSERLST. 8POL	connector male 8-pin
CN010	330269	FL.STECKER 6.3/0.8	connector 6.3mm faston
CN011	330269	FL.STECKER 6.3/0.8	connector 6.3mm faston
CN012	330269	FL.STECKER 6.3/0.8	connector 6.3mm faston
CN013	330269	FL.STECKER 6.3/0.8	connector 6.3mm faston
CN018	341937	MESSERLST. 4POL	connector male 4-pin
CN019	330269	FL.STECKER 6.3/0.8	connector 6.3mm faston
CN020	344862	MESSERLST. 8POL	connector male 8-pin
CN08X	343516	FL.STECKER 4.8/0.5	connector 4.8mm faston

170074 CPS 1 US 120V POWER-AMP				
Pos. Nr.	Best. Nr.			
Ref. No.	Part No.	Bezeichnung		Description
CN18X	341937	MESSERLST. 4POL		connector male 4-pin
CN20X	344862	MESSERLST. 8POL		connector male 8-pin
CN501	354692	STIFTLEISTE 3POL		connector male 3-pin
CN502	354692	STIFTLEISTE 3POL		connector male 3-pin
C0001	342923	KO-FOL 0.220MF 63V 5%		cap mylar 220nF
C0002	307445	KO-EL 10.000MF 35V		cap electrolytic 10uF/35V
C0005	329021	KO-KER 0.10MF 100V 20%		cap ceramic 100nF
C0006	329021	KO-KER 0.10MF 100V 20%		cap ceramic 100nF
C0007	343530	KO-EL 47.000MF 50V		cap electrolytic 47uF/50V
C0008	329021	KO-KER 0.10MF 100V 20%		cap ceramic 100nF
C0011	351835	KO-EL 4700.000MF 100V 20%		cap electrolytic 4700uF/100
C0012	351835	KO-EL 4700.000MF 100V 20%		cap electrolytic 4700uF/100
C0013	351835	KO-EL 4700.000MF 100V 20%		cap electrolytic 4700uF/100
C0014	351835	KO-EL 4700.000MF 100V 20%		cap electrolytic 4700uF/100
C0015	341714	KO-SO 0.10MF 275V 20% K		safety cap 100nF/275V
C0016	329021	KO-KER 0.10MF 100V 20%		cap ceramic 100nF
C0017	329021	KO-KER 0.10MF 100V 20%		cap ceramic 100nF
C0018	327366	KO-EL 4.700MF 50V BIP		cap electrolytic 4.7uF/50V
C0019	329021	KO-KER 0.10MF 100V 20%		cap ceramic 100nF
C0022	329021	KO-KER 0.10MF 100V 20%		cap ceramic 100nF
C0023	329021	KO-KER 0.10MF 100V 20%		cap ceramic 100nF
C0024	335935	KO-EL 2200.000MF 35V		cap electrolytic 2200uF/35V
C0025	335935	KO-EL 2200.000MF 35V		cap electrolytic 2200uF/35V
C0026	343530	KO-EL 47.000MF 50V		cap electrolytic 47uF/50V
C0027	343530	KO-EL 47.000MF 50V		cap electrolytic 47uF/50V
C0028	301524	KO-KER 47.0PF 500V 10%		cap ceramic 47pF
C0029	301524	KO-KER 47.0PF 500V 10%		cap ceramic 47pF
C0030	329021	KO-KER 0.10MF 100V 20%		cap ceramic 100nF
C0031	329021	KO-KER 0.10MF 100V 20%		cap ceramic 100nF
C0032	341714	KO-SO 0.10MF 275V 20% K		safety cap 100nF/275V
C0100	301558	KO-KER 33.0PF 100V 2%		cap ceramic 33pF
C0101	301558	KO-KER 33.0PF 100V 2%		cap ceramic 33pF
C0102	301478	KO-EL 22.000MF 63V		cap electrolytic 22uF/63V
C0103	335787	KO-KER 15.0PF 100V 2%		cap ceramic 15pF
C0104	335787	KO-KER 15.0PF 100V 2%		cap ceramic 15pF
C0105	301470	KO-EL 4.700MF 63V		cap electrolytic 4.7uF/63V
C0106	327390	KO-FOL 470.000PF 100V 5%		cap mylar 470pF
C0107	340988	KO-FOL 0.470MF 63V 5%		cap mylar 470nF
C0108	301530	KO-KER 100.0PF 500V 10%		cap ceramic 100pF
C0109	343532	KO-EL 100.000MF 25V		cap electrolytic 100uF/25V
C0110	343532	KO-EL 100.000MF 25V		cap electrolytic 100uF/25V
C0111	340988	KO-FOL 0.470MF 63V 5%		cap mylar 470nF
C0112	343532	KO-EL 100.000MF 25V		cap electrolytic 100uF/25V
C0113	343532	KO-EL 100.000MF 25V		cap electrolytic 100uF/25V
C0114	329021	KO-KER 0.10MF 100V 20%		cap ceramic 100nF
C0115	329021	KO-KER 0.10MF 100V 20%		cap ceramic 100nF
C0116	343532	KO-EL 100.000MF 25V		cap electrolytic 100uF/25V
C0117	351994	KO-KER 120.0PF 500V 2%		cap ceramic 120pF
C0118	351994	KO-KER 120.0PF 500V 2%		cap ceramic 120pF
C0119	301458	KO-EL 2.200MF 63V		cap electrolytic 2.2uF/63V
C0120	356605	KO-FOL 0.100MF 250V 5%		cap mylar 100nF
C0123	301519	KO-KER 10.0PF 500V 10%		cap ceramic 10pF

170074 CPS 1 US 120V POWER-AMP					
Pos. Nr.	Best. Nr.	Bezeichnung			Description
Ref. No.	Part No.				
C0124	301519	KO-KER	10.0PF	500V 10%	cap ceramic 10pF
C0125	301474	KO-EL	22.000MF	16V BIP	cap bip electr. 22uF/16V
C0126	329021	KO-KER	0.10MF	100V 20%	cap ceramic 100nF
C0127	329021	KO-KER	0.10MF	100V 20%	cap ceramic 100nF
C0128	329021	KO-KER	0.10MF	100V 20%	cap ceramic 100nF
C0129	329021	KO-KER	0.10MF	100V 20%	cap ceramic 100nF
C0300	301558	KO-KER	33.0PF	100V 2%	cap ceramic 33pF
C0301	301558	KO-KER	33.0PF	100V 2%	cap ceramic 33pF
C0302	301478	KO-EL	22.000MF	63V	cap electrolytic 22uF/63V
C0303	335787	KO-KER	15.0PF	100V 2%	cap ceramic 15pF
C0304	335787	KO-KER	15.0PF	100V 2%	cap ceramic 15pF
C0305	301470	KO-EL	4.700MF	63V	cap electrolytic 4.7uF/63V
C0306	327390	KO-FOL	470.000PF	100V 5%	cap mylar 470pF
C0307	340988	KO-FOL	0.470MF	63V 5%	cap mylar 470nF
C0308	301530	KO-KER	100.0PF	500V 10%	cap ceramic 100pF
C0309	343532	KO-EL	100.000MF	25V	cap electrolytic 100uF/25V
C0310	343532	KO-EL	100.000MF	25V	cap electrolytic 100uF/25V
C0311	340988	KO-FOL	0.470MF	63V 5%	cap mylar 470nF
C0312	343532	KO-EL	100.000MF	25V	cap electrolytic 100uF/25V
C0313	343532	KO-EL	100.000MF	25V	cap electrolytic 100uF/25V
C0314	329021	KO-KER	0.10MF	100V 20%	cap ceramic 100nF
C0315	329021	KO-KER	0.10MF	100V 20%	cap ceramic 100nF
C0316	343532	KO-EL	100.000MF	25V	cap electrolytic 100uF/25V
C0317	351994	KO-KER	120.0PF	500V 2%	cap ceramic 120pF
C0318	351994	KO-KER	120.0PF	500V 2%	cap ceramic 120pF
C0319	301458	KO-EL	2.200MF	63V	cap electrolytic 2.2uF/63V
C0320	356605	KO-FOL	0.100MF	250V 5%	cap mylar 100nF
C0323	301519	KO-KER	10.0PF	500V 10%	cap ceramic 10pF
C0324	301519	KO-KER	10.0PF	500V 10%	cap ceramic 10pF
C0325	301474	KO-EL	22.000MF	16V BIP	cap bip electr. 22uF/16V
C0326	329021	KO-KER	0.10MF	100V 20%	cap ceramic 100nF
C0327	329021	KO-KER	0.10MF	100V 20%	cap ceramic 100nF
C0328	329021	KO-KER	0.10MF	100V 20%	cap ceramic 100nF
C0329	329021	KO-KER	0.10MF	100V 20%	cap ceramic 100nF
C0501	329021	KO-KER	0.10MF	100V 20%	cap ceramic 100nF
C0502	329021	KO-KER	0.10MF	100V 20%	cap ceramic 100nF
C0503	301543	KO-KER	330.0PF	500V 10%	cap ceramic 330pF
C0504	301543	KO-KER	330.0PF	500V 10%	cap ceramic 330pF
C0505	301543	KO-KER	330.0PF	500V 10%	cap ceramic 330pF
C0506	301543	KO-KER	330.0PF	500V 10%	cap ceramic 330pF
C0507	301558	KO-KER	33.0PF	100V 2%	cap ceramic 33pF
C0508	301558	KO-KER	33.0PF	100V 2%	cap ceramic 33pF
C0509	301558	KO-KER	33.0PF	100V 2%	cap ceramic 33pF
C0510	301558	KO-KER	33.0PF	100V 2%	cap ceramic 33pF
C0511	340523	KO-EL	22.000MF	16V	cap electrolytic 22uF/16V
C0512	340523	KO-EL	22.000MF	16V	cap electrolytic 22uF/16V
C0513	340523	KO-EL	22.000MF	16V	cap electrolytic 22uF/16V
C0514	340523	KO-EL	22.000MF	16V	cap electrolytic 22uF/16V
C0515	340523	KO-EL	22.000MF	16V	cap electrolytic 22uF/16V
C0516	340523	KO-EL	22.000MF	16V	cap electrolytic 22uF/16V
C0517	329021	KO-KER	0.10MF	100V 20%	cap ceramic 100nF
C0518	329021	KO-KER	0.10MF	100V 20%	cap ceramic 100nF

170074 CPS 1 US 120V POWER-AMP					
Pos. Nr.	Best. Nr.				
Ref. No.	Part No.	Bezeichnung		Description	
C0519	329021	KO-KER	0.10MF 100V 20%		cap ceramic 100nF
C0520	340522	KO-EL	10.000MF 35V		cap electrolytic 10uF/35
C0521	340522	KO-EL	10.000MF 35V		cap electrolytic 10uF/35
D0002	304360	DIODE 1N 4007	GEGURTET		diode 1N 4002
D0003	301254	DIODE 1N 4148	AXIAL		diode 1N 4148
D0004	301254	DIODE 1N 4148	AXIAL		diode 1N 4148
D0005	301254	DIODE 1N 4148	AXIAL		diode 1N 4148
D0006	301254	DIODE 1N 4148	AXIAL		diode 1N 4148
D0007	301254	DIODE 1N 4148	AXIAL		diode 1N 4148
D0008	301254	DIODE 1N 4148	AXIAL		diode 1N 4148
D0009	304360	DIODE 1N 4007	GEGURTET		diode 1N 4002
D0010	301254	DIODE 1N 4148	AXIAL		diode 1N 4148
D0011	301254	DIODE 1N 4148	AXIAL		diode 1N 4148
D0014	301254	DIODE 1N 4148	AXIAL		diode 1N 4148
D0015	301254	DIODE 1N 4148	AXIAL		diode 1N 4148
D0016	304360	DIODE 1N 4007	GEGURTET		diode 1N 4002
D0017	304360	DIODE 1N 4007	GEGURTET		diode 1N 4002
D0018	304360	DIODE 1N 4007	GEGURTET		diode 1N 4002
D0019	304360	DIODE 1N 4007	GEGURTET		diode 1N 4002
D0020	304992	DIODZ BZX 55C	6V8 0.50W		diode zener 6V8
D0021	304992	DIODZ BZX 55C	6V8 0.50W		diode zener 6V8
D0022	304360	DIODE 1N 4007	GEGURTET		diode 1N 4002
D0023	304360	DIODE 1N 4007	GEGURTET		diode 1N 4002
D0100	301254	DIODE 1N 4148	AXIAL		diode 1N 4148
D0101	301254	DIODE 1N 4148	AXIAL		diode 1N 4148
D0102	301254	DIODE 1N 4148	AXIAL		diode 1N 4148
D0104	329511	DIODZ BZX 55C	2V4 0.50W		diode zener 2V4
D0105	309450	DIODZ BZX 55C	15V 0.50W		diode zener 15V
D0106	309450	DIODZ BZX 55C	15V 0.50W		diode zener 15V
D0107	301254	DIODE 1N 4148	AXIAL		diode 1N 4148
D0108	301254	DIODE 1N 4148	AXIAL		diode 1N 4148
D0109	301254	DIODE 1N 4148	AXIAL		diode 1N 4148
D0110	301254	DIODE 1N 4148	AXIAL		diode 1N 4148
D0111	307916	DIODZ BZX 55C	7V5 0.50W		diode zener 7V5
D0112	307916	DIODZ BZX 55C	7V5 0.50W		diode zener 7V5
D0113	301254	DIODE 1N 4148	AXIAL		diode 1N 4148
D0114	304360	DIODE 1N 4007	GEGURTET		diode 1N 4002
D0115	304360	DIODE 1N 4007	GEGURTET		diode 1N 4002
D0116	301254	DIODE 1N 4148	AXIAL		diode 1N 4148
D0117	301254	DIODE 1N 4148	AXIAL		diode 1N 4148
D0300	301254	DIODE 1N 4148	AXIAL		diode 1N 4148
D0301	301254	DIODE 1N 4148	AXIAL		diode 1N 4148
D0302	301254	DIODE 1N 4148	AXIAL		diode 1N 4148
D0304	329511	DIODZ BZX 55C	2V4 0.50W		diode zener 2V4
D0305	309450	DIODZ BZX 55C	15V 0.50W		diode zener 15V
D0306	309450	DIODZ BZX 55C	15V 0.50W		diode zener 15V
D0307	301254	DIODE 1N 4148	AXIAL		diode 1N 4148
D0308	301254	DIODE 1N 4148	AXIAL		diode 1N 4148
D0309	301254	DIODE 1N 4148	AXIAL		diode 1N 4148
D0310	301254	DIODE 1N 4148	AXIAL		diode 1N 4148
D0311	307916	DIODZ BZX 55C	7V5 0.50W		diode zener 7V5
D0312	307916	DIODZ BZX 55C	7V5 0.50W		diode zener 7V5

170074 CPS 1 US 120V POWER-AMP				
Pos. Nr.	Best. Nr.			
Ref. No.	Part No.	Bezeichnung		Description
D0313	301254	DIODE 1N 4148	AXIAL	diode 1N 4148
D0314	304360	DIODE 1N 4007	GEGURTET	diode 1N 4002
D0315	304360	DIODE 1N 4007	GEGURTET	diode 1N 4002
D0316	301254	DIODE 1N 4148	AXIAL	diode 1N 4148
D0317	301254	DIODE 1N 4148	AXIAL	diode 1N 4148
D0501	304360	DIODE 1N 4007	GEGURTET	diode 1N 4002
D0502	304360	DIODE 1N 4007	GEGURTET	diode 1N 4002
D0503	354547	LED GN 5MM	LOW CURRENT	led green
D0504	354546	LED RT 5MM	LOW CURRENT	led red
D0505	354546	LED RT 5MM	LOW CURRENT	led red
D0508	354546	LED RT 5MM	LOW CURRENT	led red
D0509	301254	DIODE 1N 4148	AXIAL	diode 1N 4148
D0510	354547	LED GN 5MM	LOW CURRENT	led green
D0511	354547	LED GN 5MM	LOW CURRENT	led green
D0512	301254	DIODE 1N 4148	AXIAL	diode 1N 4148
E0001	354859	RELAIS 793-P-1C-S-24V	DC	relay 24V
E0100	354859	RELAIS 793-P-1C-S-24V	DC	relay 24V
E0300	354859	RELAIS 793-P-1C-S-24V	DC	relay 24V
F0001	302582	SICHER T 1	A 250V	fuse 1A slow blow
F0002	302582	SICHER T 1	A 250V	fuse 1A slow blow
F0003	351850	SICHER T 15	A 250V	fuse 15 A slow blow
H0001	343457	DICKS-NETZW.	8PIN 2%	res.network 8x10k
H0002	343457	DICKS-NETZW.	8PIN 2%	res.network 8x10k
H0100	343456	DICKS-NETZW.	8PIN 2%	res.network 8x4k7
H0101	343457	DICKS-NETZW.	8PIN 2%	res.network 8x10k
H0300	343456	DICKS-NETZW.	8PIN 2%	res.network 8x4k7
H0301	343457	DICKS-NETZW.	8PIN 2%	res.network 8x10k
I0001	332985	IC TL 074	CN	IC TL 074 CN
I0100	327197	IC NE 5532	P 2FACH OP	IC NE 5532 N
I0101	307421	IC CA 3080	E OTA	IC CA 3080 E
I0102	332985	IC TL 074	CN	IC TL 074 CN
I0103	338359	IC LM 308	AN	IC LM 308 A
I0300	327197	IC NE 5532	P 2FACH OP	IC NE 5532 N
I0301	307421	IC CA 3080	E OTA	IC CA 3080 E
I0302	332985	IC TL 074	CN	IC TL 074 CN
I0303	338359	IC LM 308	AN	IC LM 308 A
I0501	327197	IC NE 5532	P 2FACH OP	IC NE 5532 N
I0502	327197	IC NE 5532	P 2FACH OP	IC NE 5532 N
JS001	338835	STECKER-KALTGERÄTE		connector male mains
JS501	351815	BUCHSE-FL. XLR 3POL	SW	xlr connector female 3-pole
JS504	351815	BUCHSE-FL. XLR 3POL	SW	xlr connector female 3-pole
L0100	348592	FILTERSP. 2.50UH/0.004OHM		coil 2.5uH
L0300	348592	FILTERSP. 2.50UH/0.004OHM		coil 2.5uH
Q0001	306928	TRANS BC 560	C	transistor BC 560 C
Q0002	306928	TRANS BC 560	C	transistor BC 560 C
Q0003	306928	TRANS BC 560	C	transistor BC 560 C
Q0004	306928	TRANS BC 560	C	transistor BC 560 C
Q0005	306928	TRANS BC 560	C	transistor BC 560 C
Q0008	307150	TRANS BC 337-25	TO 92	transistor BC 337-25
Q0009	301184	TRANS BC 550	C	transistor BC 550 B
Q0010	348591	TRANS BC 618	DARL. TO 92	transistor BC 618
Q0011	301184	TRANS BC 550	C	transistor BC 550 B

170074 CPS 1 US 120V POWER-AMP					
Pos. Nr.	Best. Nr.				
Ref. No.	Part No.	Bezeichnung		Description	
Q0012	307150	TRANS BC 337-25	TO 92	transistor BC 337-25	
Q0017	307150	TRANS BC 337-25	TO 92	transistor BC 337-25	
Q0018	307430	TRANS BC 327-25	TO 92	transistor BC 327-25	
Q0019	307430	TRANS BC 327-25	TO 92	transistor BC 327-25	
Q0020	301235	TRANS BD 242 B		transistor BD 242 B	
Q0021	307150	TRANS BC 337-25	TO 92	transistor BC 337-25	
Q0022	301236	TRANS BD 241 B		transistor BD 241 B	
Q0023	307150	TRANS BC 337-25	TO 92	transistor BC 337-25	
Q0100	348421	TRANS 2N 3906		transistor 2N 3906	
Q0101	335763	TRANS 2N 3904		transistor 2N 3904	
Q0103	330264	TRANS J 111		transistor J 111 A	
Q0104	335763	TRANS 2N 3904		transistor 2N 3904	
Q0105	348421	TRANS 2N 3906		transistor 2N 3906	
Q0106	348422	TRANS MPSA 42		transistor MPSA 42	
Q0107	348423	TRANS MPSA 92		transistor MPSA 92	
Q0108	335763	TRANS 2N 3904		transistor 2N 3904	
Q0109	348421	TRANS 2N 3906		transistor 2N 3906	
Q0110	348422	TRANS MPSA 42		transistor MPSA 42	
Q0111	348423	TRANS MPSA 92		transistor MPSA 92	
Q0112	335763	TRANS 2N 3904		transistor 2N 3904	
Q0113	348421	TRANS 2N 3906		transistor 2N 3906	
Q0114	335763	TRANS 2N 3904		transistor 2N 3904	
Q0115	348421	TRANS 2N 3906		transistor 2N 3906	
Q0116	338869	TRANS MJE 350		transistor MJE 350	
Q0117	338868	TRANS MJE 340		transistor MJE 340	
Q0118	348409	TRANS 2SC 4793		transistor 2SC 4793	
Q0119	348421	TRANS 2N 3906		transistor 2N 3906	
Q0120	335763	TRANS 2N 3904		transistor 2N 3904	
Q0121	335763	TRANS 2N 3904		transistor 2N 3904	
Q0122	348421	TRANS 2N 3906		transistor 2N 3906	
Q0123	351981	TRANS MJL 3281 A		transistor MJL 3281 A	
Q0124	351982	TRANS MJL 1302 A		transistor MJL 1302 A	
Q0125	331657	TRANS MJ 15022		transistor MJ 15022	
Q0126	331658	TRANS MJ 15023		transistor MJ 15023	
Q0127	331657	TRANS MJ 15022		transistor MJ 15022	
Q0128	331658	TRANS MJ 15023		transistor MJ 15023	
Q0129	331657	TRANS MJ 15022		transistor MJ 15022	
Q0130	331658	TRANS MJ 15023		transistor MJ 15023	
Q0131	331657	TRANS MJ 15022		transistor MJ 15022	
Q0132	331658	TRANS MJ 15023		transistor MJ 15023	
Q0135	348422	TRANS MPSA 42		transistor MPSA 42	
Q0136	348423	TRANS MPSA 92		transistor MPSA 92	
Q0137	348423	TRANS MPSA 92		transistor MPSA 92	
Q0138	348422	TRANS MPSA 42		transistor MPSA 42	
Q0139	307911	TRANS BF 393		transistor BF 391	
Q0140	307911	TRANS BF 393		transistor BF 391	
Q0141	348423	TRANS MPSA 92		transistor MPSA 92	
Q0142	348423	TRANS MPSA 92		transistor MPSA 92	
Q0143	348421	TRANS 2N 3906		transistor 2N 3906	
Q0144	348421	TRANS 2N 3906		transistor 2N 3906	
Q0145	335763	TRANS 2N 3904		transistor 2N 3904	
Q0146	306928	TRANS BC 560 C		transistor BC 560 C	

170074 CPS 1 US 120V POWER-AMP			
Pos. Nr.	Best. Nr.		
Ref. No.	Part No.	Bezeichnung	Description
Q0300	348421	TRANS 2N 3906	transistor 2N 3906
Q0301	335763	TRANS 2N 3904	transistor 2N 3904
Q0303	330264	TRANS J 111	transistor J 111 A
Q0304	335763	TRANS 2N 3904	transistor 2N 3904
Q0305	348421	TRANS 2N 3906	transistor 2N 3906
Q0306	348422	TRANS MPSA 42	transistor MPSA 42
Q0307	348423	TRANS MPSA 92	transistor MPSA 92
Q0308	335763	TRANS 2N 3904	transistor 2N 3904
Q0309	348421	TRANS 2N 3906	transistor 2N 3906
Q0310	348422	TRANS MPSA 42	transistor MPSA 42
Q0311	348423	TRANS MPSA 92	transistor MPSA 92
Q0312	335763	TRANS 2N 3904	transistor 2N 3904
Q0313	348421	TRANS 2N 3906	transistor 2N 3906
Q0314	335763	TRANS 2N 3904	transistor 2N 3904
Q0315	348421	TRANS 2N 3906	transistor 2N 3906
Q0316	338869	TRANS MJE 350	transistor MJE 350
Q0317	338868	TRANS MJE 340	transistor MJE 340
Q0318	348409	TRANS 2SC 4793	transistor 2SC 4793
Q0319	348421	TRANS 2N 3906	transistor 2N 3906
Q0320	335763	TRANS 2N 3904	transistor 2N 3904
Q0321	335763	TRANS 2N 3904	transistor 2N 3904
Q0322	348421	TRANS 2N 3906	transistor 2N 3906
Q0323	351981	TRANS MJL 3281 A	transistor MJL 3281 A
Q0324	351982	TRANS MJL 1302 A	transistor MJL 1302 A
Q0327	331657	TRANS MJ 15022	transistor MJ 15022
Q0328	331658	TRANS MJ 15023	transistor MJ 15023
Q0329	331657	TRANS MJ 15022	transistor MJ 15022
Q0330	331658	TRANS MJ 15023	transistor MJ 15023
Q0331	331657	TRANS MJ 15022	transistor MJ 15022
Q0332	331658	TRANS MJ 15023	transistor MJ 15023
Q0333	331657	TRANS MJ 15022	transistor MJ 15022
Q0334	331658	TRANS MJ 15023	transistor MJ 15023
Q0335	348422	TRANS MPSA 42	transistor MPSA 42
Q0336	348423	TRANS MPSA 92	transistor MPSA 92
Q0337	348423	TRANS MPSA 92	transistor MPSA 92
Q0338	348422	TRANS MPSA 42	transistor MPSA 42
Q0339	307911	TRANS BF 393	transistor BF 391
Q0340	307911	TRANS BF 393	transistor BF 391
Q0341	348423	TRANS MPSA 92	transistor MPSA 92
Q0342	348423	TRANS MPSA 92	transistor MPSA 92
Q0343	348421	TRANS 2N 3906	transistor 2N 3906
Q0344	348421	TRANS 2N 3906	transistor 2N 3906
Q0345	335763	TRANS 2N 3904	transistor 2N 3904
Q0346	306928	TRANS BC 560 C	transistor BC 560 C
Q0501	306928	TRANS BC 560 C	transistor BC 560 C
Q0502	348422	TRANS MPSA 42	transistor MPSA 42
Q0503	348422	TRANS MPSA 42	transistor MPSA 42
Q0504	301184	TRANS BC 550 C	transistor BC 550 B
Q0505	301184	TRANS BC 550 C	transistor BC 550 B
Q0506	306928	TRANS BC 560 C	transistor BC 560 C
Q0507	306928	TRANS BC 560 C	transistor BC 560 C
R0037	348490	WI-SO NTC K 164/100K/J	safety component NTC

170074 CPS 1 US 120V POWER-AMP					
Pos. Nr.	Best. Nr.	Bezeichnung			Description
Ref. No.	Part No.				
R0065	348550	WI-SO	NTC 10 OHM	K	safety resistor 10 Ohm
R0185	348456	WI-DR	2X 0.22 OHM 5.00W 5%		resistor 2x0.22 Ohm 5watt
R0188	348456	WI-DR	2X 0.22 OHM 5.00W 5%		resistor 2x0.22 Ohm 5watt
R0191	348456	WI-DR	2X 0.22 OHM 5.00W 5%		resistor 2x0.22 Ohm 5watt
R0194	348456	WI-DR	2X 0.22 OHM 5.00W 5%		resistor 2x0.22 Ohm 5watt
R0208	348593	WI-SO	NTC K 164/2.2K		safety component NTC
R0209	348593	WI-SO	NTC K 164/2.2K		safety component NTC
R0223	341713	WI-DR	4.70 OHM 4.00W 5%		resistor 4.70 Ohm 4watt
R0225	341713	WI-DR	4.70 OHM 4.00W 5%		resistor 4.70 Ohm 4watt
R0227	341713	WI-DR	4.70 OHM 4.00W 5%		resistor 4.70 Ohm 4watt
R0388	348456	WI-DR	2X 0.22 OHM 5.00W 5%		resistor 2x0.22 Ohm 5watt
R0391	348456	WI-DR	2X 0.22 OHM 5.00W 5%		resistor 2x0.22 Ohm 5watt
R0394	348456	WI-DR	2X 0.22 OHM 5.00W 5%		resistor 2x0.22 Ohm 5watt
R0397	348456	WI-DR	2X 0.22 OHM 5.00W 5%		resistor 2x0.22 Ohm 5watt
R0408	348593	WI-SO	NTC K 164/2.2K		safety component NTC
R0409	348593	WI-SO	NTC K 164/2.2K		safety component NTC
R0423	341713	WI-DR	4.70 OHM 4.00W 5%		resistor 4.70 Ohm 4watt
R0425	341713	WI-DR	4.70 OHM 4.00W 5%		resistor 4.70 Ohm 4watt
R0427	341713	WI-DR	4.70 OHM 4.00W 5%		resistor 4.70 Ohm 4watt
S0001	344037	SCHALTER-RAST 2XUM			switch dpdt latching
S0002	338886	SCHALTER-SCHIEBE L202-02-1-			switch slide
S0500	344037	SCHALTER-RAST 2XUM			switch dpdt latching
VR100	348486	WI-TRI	47.00 KOHM	LIN	pot trim 47k Ohm lin
VR101	348674	WI-TRI	250.00 OHM	LIN	pot trim 220 Ohm lin
VR300	348486	WI-TRI	47.00 KOHM	LIN	pot trim 47k Ohm lin
VR301	348674	WI-TRI	250.00 OHM	LIN	pot trim 220 Ohm lin
VR501	343250	P-DREH	10KOHM	LIN B	potentiometer 10kohm lin
VR502	343250	P-DREH	10KOHM	LIN B	potentiometer 10kohm lin
00030	303576	SICHER-HALTE-FEDER			fuse clip
00040	348855	SICHER-HALTE-FEDER 122090.			fuse clip
00075	354306	STIFTLAISTE 16POL			connector male 16-pin
00050	348341	FEDERLEISTE 3POL CE100-			connector female 3-pole

MEMO